

# INSTALLATION, OPERATING AND MAINTENANCE MANUAL



FOR FULLY AUTOMATIC FILTERS AND NEUTRALIZERS WITH THE 5610F VALVE

**PACKAGING:** All automatic filters are shipped from the factory in cartons.

**COMPONENTS INCLUDE:** fiberglass mineral tank, valve, distributor tube assembly & mineral.

## INSTALLATION:

Place filter in desired location close to water supply inlet, after pressure tank, and near a source for waste water, (utility sink, floor drain or sewer line) keeping far enough away from walls and other obstructions to allow enough room for servicing the unit. If a water softener is also to be installed, generally it will be placed in line after the neutralizer or filter.

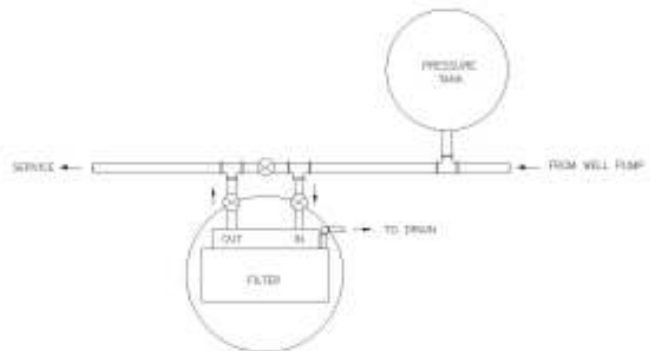

From water supply → filter → softener → to service

Remove control valve from mineral tank by turning counter-clockwise. Plug open end (top) of distributor tube assembly to prevent mineral from entering (**Fig.A**). Add mineral. **DO NOT OVERFILL.** There must be at least 16" of space between the top of the tank and mineral (**Fig.B**). Remove plug from the top of the distributor tube.

Install control valve making sure the distributor tube is slipped into the center hole on the bottom of the control valve. Pipe filter into service line. Use of a bypass valve is recommended. Arrows are molded into valve and bypass valve to show direction of flow.

The drain line must be piped to an open drain with air gap between the drain and the sewer lines (**Fig.C**). Under no circumstances should there be a direct connection with sanitary sewage facilities. If it is necessary to run the drain pipe overhead, (not to exceed 5' above valve) be sure to increase the pipe size and follow all plumbing procedures to hold friction and restrictions to a minimum.

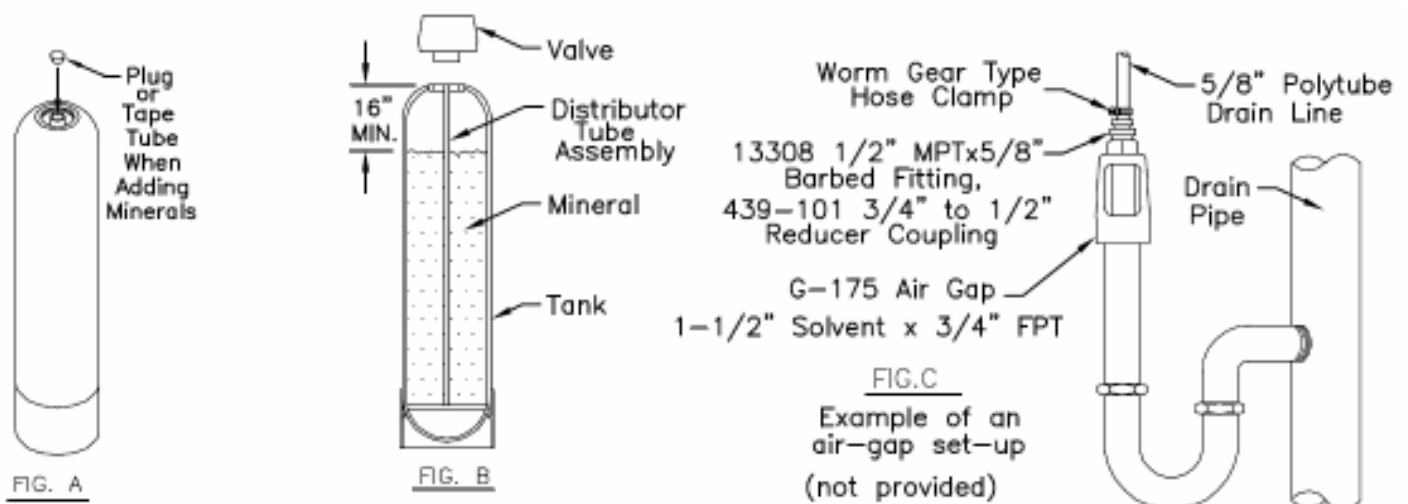

**FIG.C**  
Example of an air-gap set-up (not provided)

Turn the large Manual Regeneration knob to the “**IN SERV.**” position. Open bypass, if used. Open water supply valve to approximately one-quarter of its maximum flow position to allow water to flow slowly into the mineral tank. When flow stops, **TURN OFF WATER SUPPLY**. Turn the control knob to backwash position and slowly turn on the water supply until the valve is open to its maximum position. Let the water go to drain until it becomes clear. Turn control to service position.

Plug the electrical cord into a receptacle. **DO NOT** plug into an outlet controlled by a wall switch or pull chain that could be inadvertently turned off. Look in sight hole in back of the motor to see that the motor is running.

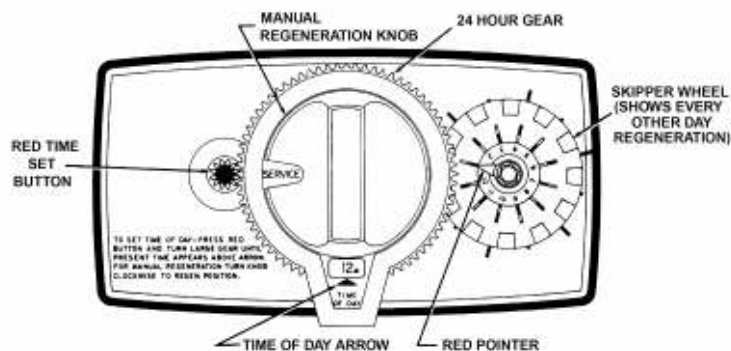

Set backwash frequency. The filter should be backwashed every 3-6 days, but must be backwashed at least once every 12 days. Rotate the “skipper wheel” until the red pointer is at “1” (**Fig.D**). Each metal tab on the skipper wheel represents one day. Set the days that backwash is to occur by sliding tabs on the skipper wheel outward to expose trip fingers. Set the actual time of day on the control valve by pressing the red time set button and turning the time of day gear. Backwash is factory programmed for 12:01 A.M. For multiple tank installation, each tank must be backwashed at separate times; set a different time of day on each timer (about 2 hours apart), or set each tank to backwash on different days.

**MAINTENANCE:**

**ACID NEUTRALIZERS, (7-EDAN-, 7-EAN-):** Mineral used: Calcite. Calcite will dissolve in proportion to the amount of acid in the raw water. The amount of mineral in the tank should be monitored and replaced periodically. A tank with a dome plug is recommended so that mineral may be added without removing the control valve. To check level of calcite in the mineral tank **shut off water supply to the filter**. Turn manual regeneration knob clockwise to the backwash position to relieve pressure in the tank. Remove hexagonal dome plug. A small amount of water will be lost from the tank. Insert a dipstick into the dome hole until the stick reaches mineral level. Mark and remove the stick. Measure the marked distance on the stick. This number should never be less than 16”. Replace calcite before the mineral level is 24” from the dome hole. Adding calcite will displace the water in the tank. This water may be siphoned out to reduce spillage. As each installation will use a different amount of calcite, monitoring the mineral level once a month for the first few months of operation should give a fairly good indication as to how frequently the calcite will need to be replenished. Replace the dome plug. Turn on the water supply to the neutralizer. Allow water to run to drain until it becomes clear. Return manual regeneration knob to the service position by turning the knob clockwise.

A pH test kit may also be used to monitor the pH level to help determine when mineral needs to be replenished. Calcite will add approximately four (4) or more grains per gallon to the original hardness of the raw water. This should be kept in mind when figuring regeneration cycle for a water softener. If a Corosex/Calcite mixture is recommended to be used (for high flow rates or very low pH level), mix one part Corosex with four parts Calcite **BEFORE** adding to the tank. **NOTE: 1 cu ft. of calcite = 85 lbs.**

**IRON FILTERS, (7-EIM-):** Mineral used: Birm. No chemical regenerant is required, backwash periodically. No hardness is added to the water. For clear water iron, when the pH is less than seven (7) in the raw water, a water softener should be used in place of the iron filter. **Note: When using Birm for iron removal, it is necessary that the water: contain no oil or hydrogen sulfide, organic matter not to exceed 4-5 ppm, the D.O. content equal at least 15% of iron content with a pH of 6.8 or more. If the influent water has a pH of less than 6.8, neutralizing additives such as Calcite, Corosex or soda ash may be used prior to the Birm filter to raise the pH. A water having a low D.O. level may be pretreated by aeration. Chlorination greatly reduces Birm’s activity. High concentrations of chlorine compounds may deplete the catalytic coating.** \* If Manganese Greensand is used, see instruction sheet for TPIM units.

**COLOR, TASTE AND ODOR FILTERS, (7-ECT-):** Mineral used: Carbon. Used for removal of chlorine, color, taste, odor and low levels of sulfur, etc. The mineral bed should be backwashed periodically, but will in time reach the maximum absorbency. When this occurs the carbon should be completely replaced.

**SEDIMENT AND TURBIDITY, (7-EST-):** Mineral used: Filter Ag. This filter will filter out dirt, silica, etc. down to the 20-40 micron range. In most cases it has a lifetime fill and should be backwashed periodically depending on local conditions. Pressure drop is very low.

# MODEL 5610F CONTROL VALVE ASSEMBLY PARTS LIST

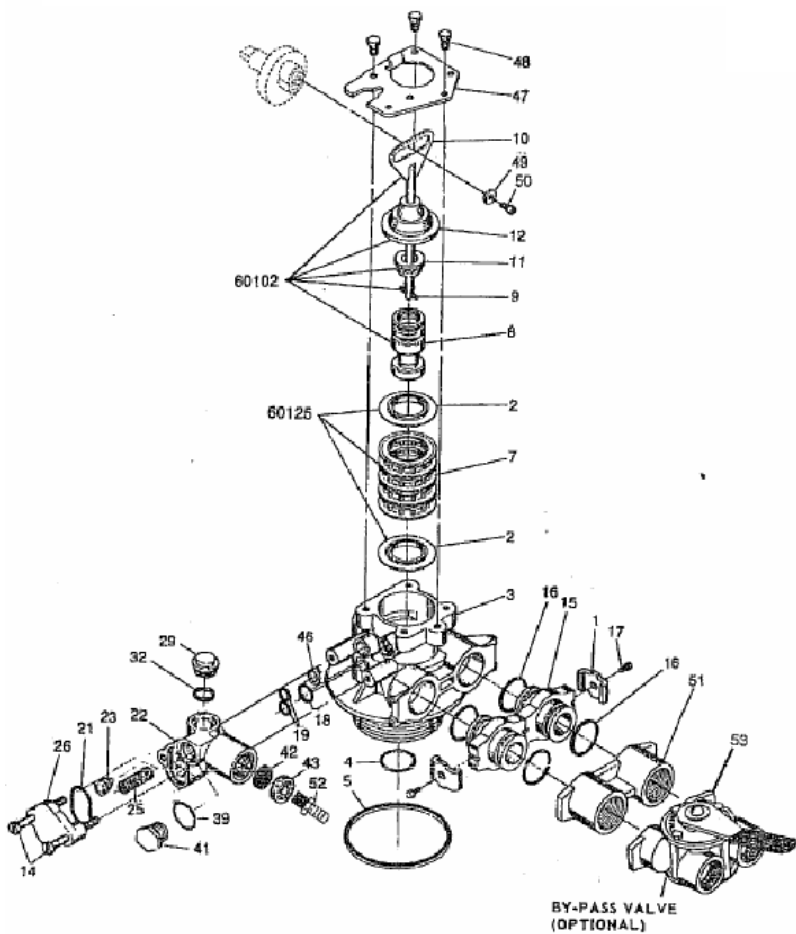

Item No.	Qty.	Part No.	Description
1	2	13255	Adapter Clips
2	5	13242	Seals
3	1	61400-12	Valve Body Assy. - 1" Dist.
4	1	13304	O-Ring
5	1	12281	O-Ring - Top of Tank
7	4	14241	Spacers
8	1	13852	Piston - Filter
9	1	10696	Piston Pin
10	1	13001	Piston Rod Assy.
11	1	12953	Piston Retainer
12	1	13446-01	End Plug Assy. - Black
14	2	13315	Screw
15	2	19228	Adapter Coupling
16	4	13305	O-Ring
17	2	13314	Screws
18	1	12638	O-Ring
19	2	13301	O-Ring
21	1	13303	O-Ring
22	1	13163	Body
23	1	10913	Nozzle - Plug
25	1	10227	Screen
26	1	13166	Cover
29	1	15155	Plug
32	1	13302	O-Ring
39	1	12977	O-Ring
41	1	13918	Plug
42	1	12092	Button 5 GPM
43	1	12408	Button 7 GPM
46	1	13173	DLFC Button Retainer
47	1	13497	Air Dispenser
48	1	13546	End Plug Retainer
49	3	12112	Screw
50	1	13363	Washer
51	1	13296	Screw
52	1	13398	Adapter - 1" NPT
53	1	13308	Drain Line Fitting
		60102-10	Piston Assy. (Items 8-12)
		60125	Seal Kit (Item 2 and 7)
		60041	1" Bypass Valve

# MODEL 5610F TIMER/DRIVE ASSEMBLY

# PARTS LIST

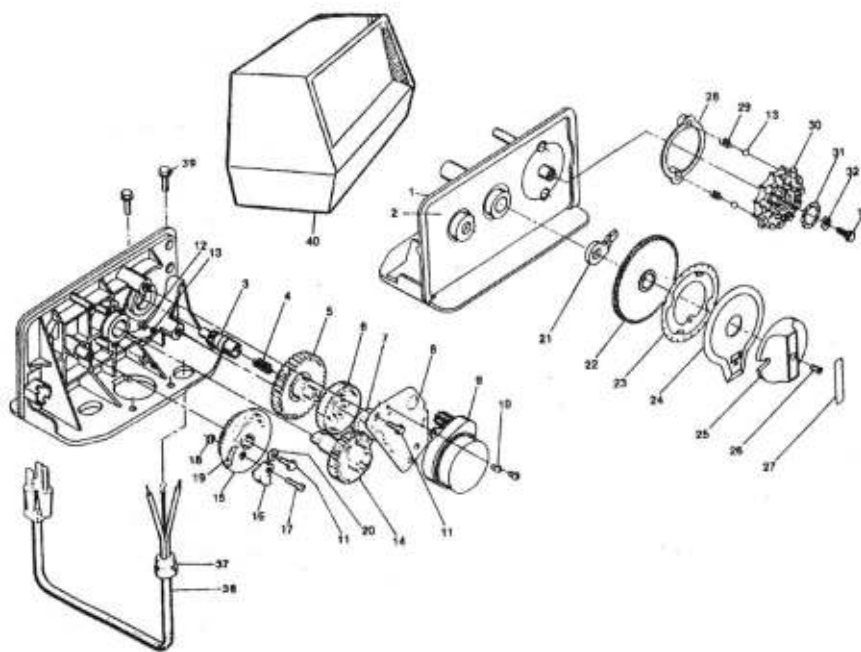

Item No.	Qty.	Part No.	Description
1	1	15494	Drive Panel
2	1	14331	Front Label
3	1	13018	Idler Pinion
4	1	13312	Spring - Idler
5	1	13017	Idler Gear
6	1	13164	Drive Gear
7	1	13299	Curved Washer
8	1	13175	Motor Mounting Plate
9	1	18743	Motor - 110V, 60Hz.
10	3	11384	Screw - Motor Mtg. & Ground
11	3	13296	Screw - Component Mounting
12	2	13311	Spring
13	2	13300	Ball
14	1	13170	Main Gear & Shaft
21	1	13011	Cycle Actuator Gear
22	1	13009	24 Hour Gear
23	1	13959	24 Hour Label
24	1	16715	Valve Position Dial
25	1	14177	Knob - Manual Regeneration
26	1	15151	Screw - Knob
28	1	13864	Skipper Wheel Ring
30	1	14381	Skipper Wheel Assy.
31	1	13429	Skipper Wheel Label
32	1	13014	Regeneration Pointer
37	1	13547	Strain Relief
38	1	11842	Electrical Cord
39	2	12473	Screw - Drive Mtg.
40	1	60226	Black Cover

# TROUBLE SHOOTING—SERVICE INSTRUCTIONS

PROBLEM	POSSIBLE CAUSE	SOLUTION
1. Filter fails to backwash:	<ul style="list-style-type: none"> <li>a. Electrical service to unit has been interrupted.</li> <li>b. Timer is defective.</li> <li>c. Power failure.</li> </ul>	<ul style="list-style-type: none"> <li>a. Assure permanent electrical service.</li> <li>b. Replace timer.</li> <li>c. Reset time of day.</li> </ul>
2. Filter “bleeds” iron:	<ul style="list-style-type: none"> <li>a. Bypass valve is open.</li> <li>b. Excessive water usage.</li> <li>c. Hot water tank rusty.</li> <li>d. Defective or stripped filter media bed.</li> <li>e. Inadequate backwash flow rate.</li> <li>f. Leak at distributor tube.</li> <li>g. Internal valve leak.</li> </ul>	<ul style="list-style-type: none"> <li>a. Close bypass valve.</li> <li>b. Reduce days between backwashing (see timer instructions). Make sure that there is not a leaking valve in the toilets/sinks.</li> <li>c. Repeated flushing of the hot water tank is required.</li> <li>d. Replace bed.</li> <li>e. Make sure filter has correct drain flow control. Be sure flow control is not clogged or drain line restricted. Be sure water pressure has not dropped.</li> <li>f. Make sure distributor tube is not cracked. Check O-Ring and tube pilot.</li> <li>g. Replace seals and spacer and/or piston.</li> </ul>
3. Loss of water pressure:	<ul style="list-style-type: none"> <li>a. Iron or turbidity buildup in water filter.</li> <li>b. Inlet of control plugged by foreign material.</li> </ul>	<ul style="list-style-type: none"> <li>a. Reduce days between backwashing so filter backwashes more often. Note: Make sure filter is sized large enough to handle water usage.</li> <li>b. Remove piston and clean control.</li> </ul>
4. Drain flows continuously:	<ul style="list-style-type: none"> <li>a. Foreign material in control valve.</li> <li>b. Internal control leak.</li> <li>c. Control valve jammed in rinse or backwash.</li> <li>d. Timer motor stopped or jammed.</li> </ul>	<ul style="list-style-type: none"> <li>a. Advance control through various regeneration positions. Remove foreign material in control.</li> <li>b. Replace seals and/or piston assy.</li> <li>c. Replace piston, seals and spacers.</li> <li>d. Replace timer.</li> </ul>

06/10



A DIVISION OF C-B TOOL CO.

1340 Manheim Pike • Lancaster, PA 17601-3196 • Phone 717-397-3521 • Fax 717-392-0266  
 www.lancasterpump.com • E-mail: info@lancasterpump.com