

EFFECTIVE: JAN. 19, 2015

STARTING WITH SERIAL NO. 1AA1

PARTS LIST

SQUARE FLANGE KEYSTONE SHALLOW WELL JET PUMPS SKS100 & SKS100H

PART NO.	REQ'D	DESCRIPTION	PART NO.	REQ'D	DESCRIPTION
825	1	1/4" NPT Pipe Plug	2488	2	Spacer
862	2	1/4-20 x 1-1/8 S.S. Screw	2661	1	Rotary Shaft Seal
1032A	2	1/8" NPT Pipe Plug	3514	1	Tetra Seal
1063	2	3/8-16 x 1 Cap Screw	6-F459U	1	1 HP Motor
1422	2	Washer	13600	1	Injector Assy for SKS100 Consist of:
1454	1	Gasket	2421	1	Body
1473	1	Diffuser	2453	1	Venturi
1872	1	Motor Adaptor	14614-B	1	Nozzle
1885	1	Priming Screen	1032A	1	1/8 NPT Plug
1961	1	Body	13690	1	Injector Assy for SKS100H Consist of:
1984	1	Impeller	2421	1	Body
2313	2	3/8-16 x 1-3/4 Bottom Cap Screw	2443	1	Venturi
2405	1	Base	14614-B	1	Nozzle
2413	2	3/8-16 x 1-1/2 Top Cap Screw	1032A	1	1/8 NPT Plug
2452	1	Sealing Ring			

NOT SHOWN:
P/N 722 "MOTOR TO SWITCH" CORD SET ... CONNECTED TO MOTOR THRU MOTOR CONDUIT HOLE.
P/N 3548 RUBBER GROMMET ... LOCATED IN MOTOR CONDUIT HOLE.
P/N 1448 RUBBER CONE GROMMET ... ON END OF CORD SET OPPOSITE MOTOR.

PACKAGED WITH PUMP:
P/N 878 1/4" NPT CLOSE NIPPLE.
PRESSURE SWITCH, 20-40 LB.

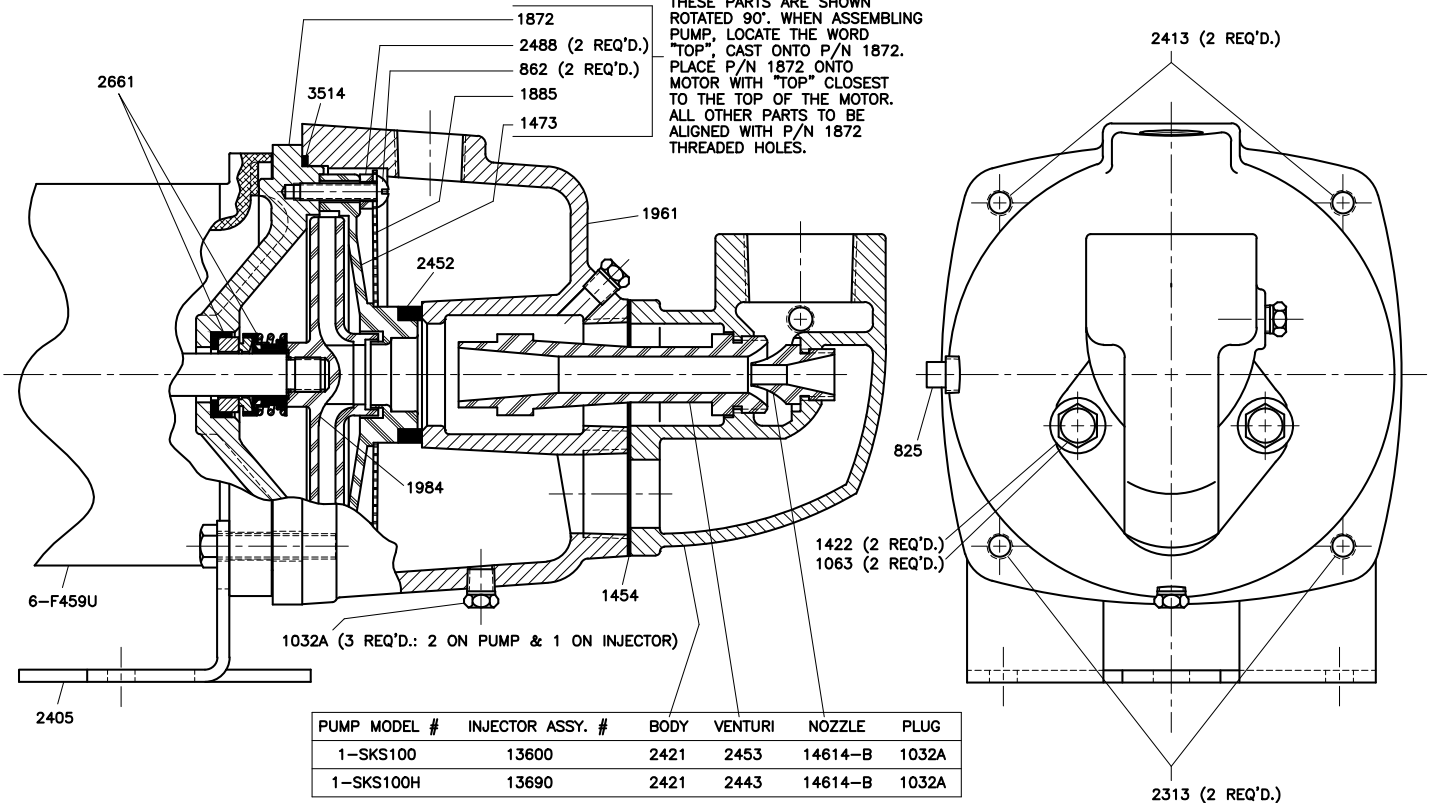

LANCASTER PUMP A DIVISION OF C-B TOOL

1340 Manheim Pike • Lancaster PA 17601-3196 • Tel: 717-397-3521 • Fax: 717-392-0266 • www.lancasterpump.com

Printed in U.S.A. - Trademark Registered - Specifications subject to change without notice.