

LANCASTER LAUNDRY TRAY WASTE WATER PUMPS



LANCASTER X99 pumps are designed for gravity feed pumping applications. They will remove clean or waste water from a laundry tray/tub/sink in an area with no floor drains. These pumps can be located below the laundry tray/tub/sink and will pump waste water to an overhead or remote drain line. No need to break through the floor for unsanitary sumps and sump pumps.

Applications include: laundry tray, wet bar sink, lavatory sink, air conditioning condensate, dehumidifier water removal.

NOT recommended for flammable or explosive liquids or liquids with solids, strong acids or caustics.
Maximum water temperature 130°F.

Automatic Operation

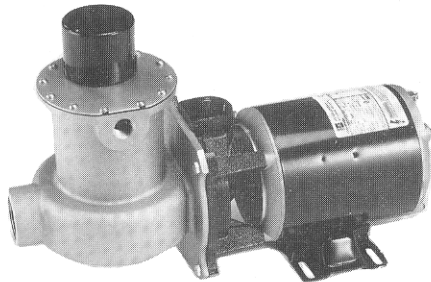

Manual Operation

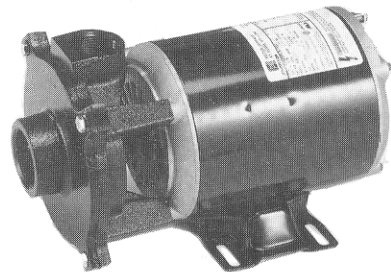

MODEL	X99A33	X99A50
HP	1/3	1/2

MODEL	X99M33	X99M50
HP	1/3	1/2

X99A SPECIFICATIONS

- Single phase, 115v, thru-bolt motor with automatic reset thermal overload protector.
- 8 ft. 16/3 SJTOW cord set with plug.
- CL30 gray iron discharge casing.
- Glass filled polypropylene semi-open impeller.
- Buna-N mechanical rotary seal and o-ring.
- Neoprene gaskets.
- Cast aluminum suction housing.
- Mechanically-activated switch.
- Inlet size: 1½" NPT Female.
- Discharge size: 1" NPT Female.
- Vent size: ½" NPT Female

X99M SPECIFICATIONS

- Single phase, 115v, thru-bolt motor with automatic reset thermal overload protector.
- 8 ft. 16/3 SJTOW cord set with plug.
- CL30 gray iron discharge casing.
- Glass filled polypropylene semi-open impeller.
- Buna-N mechanical rotary seal and o-ring.
- CL30 gray iron suction cover.
- Inlet size: 1½" NPT Female.
- Discharge size: 1" NPT Female

MODEL	HP	TOTAL HEAD IN FEET						SHUT OFFHEAD MAX. FT AT 0 GPM
		5'	10'	15'	20'	25'	30'	
		GPM						
X99A33 X99M33	1/3	31	25	18	9	-	-	25'
X99A50 X99M50	1/2	36	32	27	19	12	7	35'

MODELS X99A33 & X99A50 AUTOMATIC OPERATION

GENERAL NOTES FOR ESTIMATING ONLY
ALL DIMENSIONS ARE IN INCHES

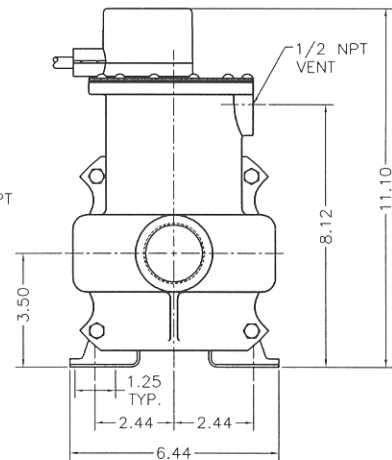
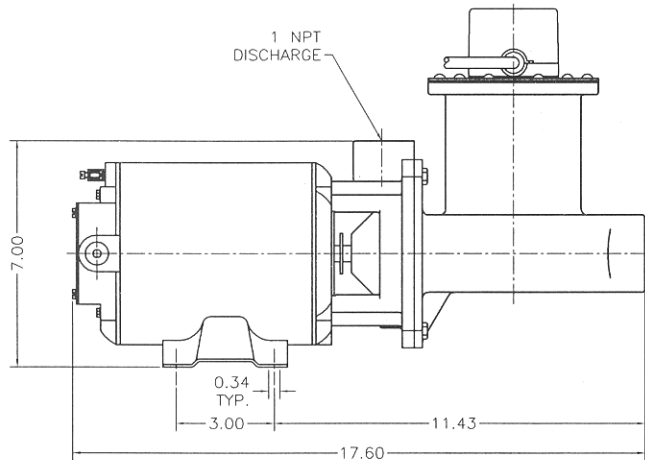
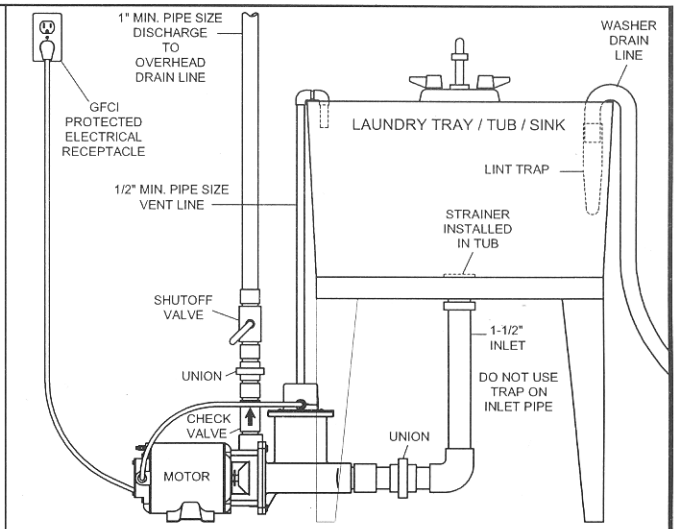
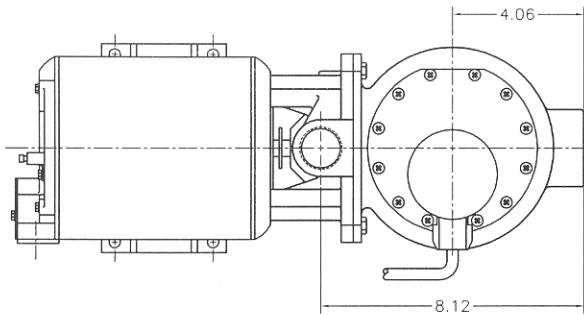

MODELS X99M33 & X99M50 MANUAL OPERATION

MANUAL OPERATION MODELS DO NOT COME SUPPLIED
WITH ANY TYPE OF SWITCH OR CONTROL DEVICE
TO TURN PUMPS ON OR OFF

GENERAL NOTES FOR ESTIMATING ONLY
ALL DIMENSIONS ARE IN INCHES

