

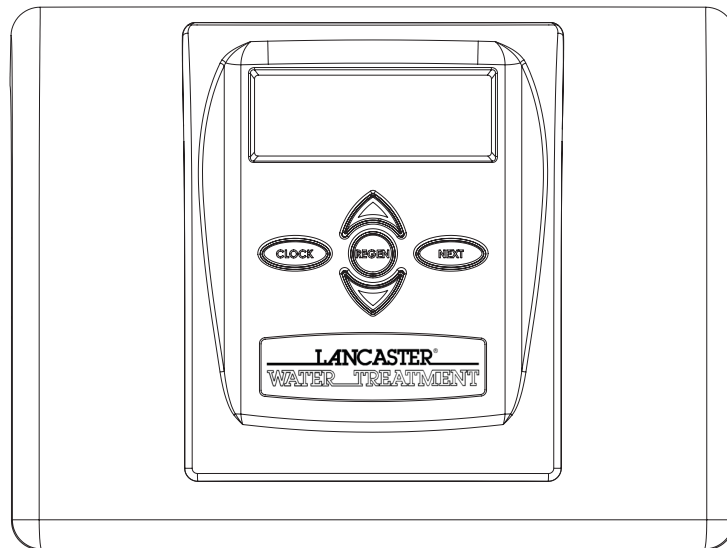

INSTALLATION, OPERATING AND SERVICE MANUAL

ELECTRONIC WATER SOFTENER WITH THE X-FACTOR CONTROL VALVE COMMERCIAL SERIES LX15, LX2 & LX2QC



Congratulations on purchasing your new **Lancaster Water Softener**. This unit is designed to give you many years of trouble free service. When installed in accordance with the following instructions and if given reasonable care, clear-soft water will be the result. For servicing and future inspection purposes, please file this booklet with your important documents.

In the event that you need assistance for servicing your water softener, please first contact the professional contractor who installed the system.

TABLE OF CONTENTS

Job Specifications	2
Inspection, Resin Loading and Assembly	3
Pre-Installation Review	4
General Installation and Service Warnings	4
Bypass Valve Operation	5
Installation Instructions, Diagrams	6-9
Placing Softener into Service	10
General Operation	10
Set Time of Day	11
Adjust Hardness, Days Between Regenerations or Time of Regeneration	11-12
Low Battery.....	12
Contact Screen Programming	12
Specifications	13
Parts Diagrams	14-25
Service Instructions	26-29
Troubleshooting	30-33

JOB SPECIFICATIONS

MODEL NO. _____
INSTALLATION DATE _____
SERIAL NUMBER _____
INSTALLER NAME _____ PHONE _____
ADDRESS _____

WATER TEST AT TIME OF INSTALLATION

_____ Hardness CaCO₃ (gpg) Other: _____
_____ Iron (ppm) _____
_____ pH _____

SIZING INFORMATION

All Water is Softened Except:

_____ Rear Hose Bib _____ Front Hose Bib _____ Kitchen Cold _____ Toilets _____ All Cold
_____ Other _____

The average family uses 50 gallons per person daily for all water uses in the home.

_____ Daily Water Usage (Gallons/Person)
x _____ Family Size (Number of people in family)
= _____ Total Gallons Per Day (For more accuracy, take water meter readings during average or peak days. Water bills may also be used to determine daily water usage. For commercial application usage estimation, consult factory if assistance is required)
x _____ Grains Per Gallon of hardness
(Note: Add 4 grains per gallon of hardness for each ppm iron for total compensated hardness)
= _____ Total Grains per Day

INSPECTION, RESIN LOADING AND ASSEMBLY

Commercial water softener systems are shipped in multiple cartons:

- mineral tank(s) with bottom distributor and riser pipe
- brine tank(s) with internal brine valve assembly
- control valve(s) with meter
- optional alternator valve or no hard water bypass valve(s)
- bag(s) of gravel support bed (for 21" diameter and larger mineral tanks)
- 1 cubic foot bags of water softener resin

Quantity of components are specific for the individual type softening system ordered.

System Model	# Mineral Tanks	LBS Gravel Support Bed per Mineral Tank	Cubic Feet Resin (# bags) per Mineral Tank

Inspect the shipping cartons and equipment for possible shipping damage or lost parts. If damage is present, notify the transportation company. The manufacturer is not responsible for damage or lost parts in shipment. Do not mistakenly discard any small parts bags when unpacking the system.

BEFORE LOADING THE MINERAL TANK WITH GRAVEL FOLLOWED BY RESIN, INSPECT THE BOTTOM LATERALS FOR ANY DAMAGE THAT MAY HAVE OCCURRED DURING SHIPPING. THE LATERALS MUST BE REPLACED IF THERE IS ANY DAMAGE.

LOADING AND ASSEMBLING THE MINERAL TANK:

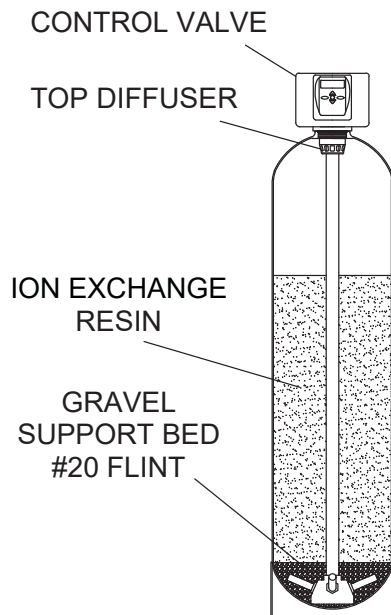
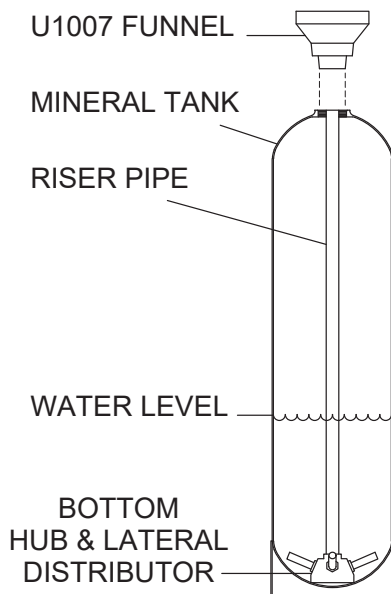

1. Place the mineral tank where you want to install it, making sure it is on a clean, level and firm surface.
2. PLUG OR TAPE THE TOP OF THE RISER PIPE to keep gravel and resin from entering. Gravel and resin must not enter riser pipe.
3. BEFORE LOADING THE GRAVEL AND RESIN, FILL THE MINERAL TANK APPROXIMATELY 1/3 FULL OF WATER. The water will act as a cushion to protect the bottom laterals from damage while filling the tank with gravel and resin.
4. For LX2QC systems, if the 4" QC Base Assy is installed on the tank opening, temporarily remove it. Use the U1007 funnel designed to snap into 4" and 6" tank openings for stability and air escape while pouring gravel and resin.
5. Load the gravel support bed first, followed by the resin. While filling, be careful to keep the riser pipe centered as best you can. The resin beads tend to stick to the funnel. Filling slowly with a small scoop to pour the resin into the funnel, using water SPARINGLY to speed flow through the funnel, will work better than trying to fill too fast.
6. After the loading is complete, remove the funnel, clean the tank opening to remove resin beads from the tank opening. Note that the resin will only fill the mineral tank approximately 1/2 to 3/4 full. The mineral tank should NEVER be filled to the top with resin. This remaining open space is called freeboard and is necessary for the resin to have room to move during the backwash cycle.
7. REMOVE THE PLUG OR TAPE FROM THE TOP OF THE RISER PIPE.
8. FINISH FILLING THE MINERAL TANK WITH WATER. This will eliminate air space and prevent excessive air-head pressure when the water softener is pressurized.
9. The control valve must now be screwed onto the mineral tank. Be sure the mineral tank's o-ring sealing surface is clean. NO pipe dope should be used on threads. As you start to screw the control valve onto the tank, make sure the hole in the center of the control valve fits over the riser pipe. The control valve should be hand-tightened, snugly, clockwise. For LX2QC systems, screw the 4" QC Base Assy with snap-fit top diffuser onto the mineral tank, lower the control valve onto the QC Base, align for plumbing and install clamp.

NOTE- 14" AND 16" DIAMETER MINERAL TANKS ARE BOTTOM VORTECH DISTRIBUTOR PLATE DESIGN; NO GRAVEL SUPPORT BED IS REQUIRED.

PRE-INSTALLATION REVIEW

WATER QUALITY: If sand or sediment is present in the water supply, a sediment filter should be installed ahead of the water softener. Your water softener has been designed to adequately reduce hardness from levels up to 100 grains per gallon. Ferrous bicarbonate iron levels up to 0.5 ppm can also be reduced. This is iron that is dissolved in water and not visible to the eye in a freshly drawn sample. After standing in contact with air, the ferrous iron will become oxidized to the ferric state and start to precipitate as a reddish brown floc. It can be seen and may cause discolored water. Air must not come in contact with water until after it has passed through the water softener. In some cases, additional treatment equipment prior to softening may be needed to treat water having special characteristics, such as: ferric hydroxide iron, iron bacteria, low pH, tastes and odors, etc. Consult your dealer if you have any questions.

This water softener is not to be used for treating water that is microbiologically unsafe or of unknown quality without adequate disinfection before or after treatment.

WATER PRESSURE: A minimum of 20 pounds of water pressure (psi) is required for regeneration. Maximum 125 psi. CAUTION: the softener cannot be subject to a vacuum due to loss of pressure (such as a water main break or submersible well pump check valve failure).

WATER TEMPERATURE: The range of water temperature is 40°F to 110°F. DO NOT install any water softener with less than 10 feet of piping between its outlet and the inlet of a water heater.

AMBIENT TEMPERATURE: DO NOT locate softener where it or its connections (including the drain and overflow lines) will ever be subject to room temperatures under 40°F.

ELECTRICITY: An uninterrupted 120 volt 60Hz outlet, within 15 feet of the softener, is required. *Make sure electrical source is not on a timer or switch.* All electrical connections must be connected according to local codes. The plug-in transformer is for dry locations only. Surge protection is recommended with all electrical connections.

DRAIN: All plumbing should be done in accordance with local plumbing codes. The distance between the drain and the water softener should be as short as possible. Correctly size drain line for the control valve's drain line flow control GPM rating (see installation instructions). Avoid elevating the drain line above the control valve where possible (see installation instructions).

BYPASS: A bypass valve should be installed so that water will be available if it should be necessary to shut off the pressure in order to service the softener.

GENERAL INSTALLATION AND SERVICE WARNINGS

The control valve and fittings are not designed to support the weight of the system or the plumbing.

Do not use Vaseline, oils, other hydrocarbon lubricants or spray silicone anywhere. A silicone lubricant may be used on black o-rings but is not necessary. **Avoid any type of lubricants, including silicone, on the clear lip seals.**

Hydrocarbons such as kerosene, benzene, gasoline, etc., may damage products that contain o-rings or plastic components. Exposure to such hydrocarbons may cause the products to leak. Do not use the product(s) contained in this document on water supplies that contain hydrocarbons such as kerosene, benzene, gasoline, etc.

This water meter should not be used as the primary monitoring device for critical or health effect applications.

The V3151 nuts are designed to be unscrewed or tightened by hand or with the special plastic wrench (V3193). If necessary, pliers can be used to unscrew the nut. Do not use a pipe wrench to tighten or loosen nuts. Do not place a screw driver in the slots on nuts and/or tap with a hammer.

Do not use pipe dope or other sealants on threads. Use of pipe dope may break down the plastics in the control valve. Use Teflon tape on the threaded inlet, outlet and drain fittings. Teflon tape is not necessary on the BPV3151 nut connection because of o-rings seals.

After completing any valve maintenance involving the drive assembly or the drive cap assembly and pistons, unplug power source jack from the printed circuit board (black wire) and plug back in or press and hold **NEXT** and **REGEN** buttons for 3 seconds. This resets the electronics and establishes the service piston position. The display should flash the software version and then reset the valve to the service position.

Solder joints near the drain must be done prior to connecting the drain line flow control fitting. Leave at least 6" between the drain line control fitting and solder joints when soldering pipes that are connected on the drain line control fitting. Failure to do this could cause interior damage to the drain line flow control fitting.

Install grounding strap on metal pipes.

This water softener is not to be used for treating water that is microbiologically unsafe or of unknown quality without adequate disinfection before or after treatment.

BYPASS VALVE

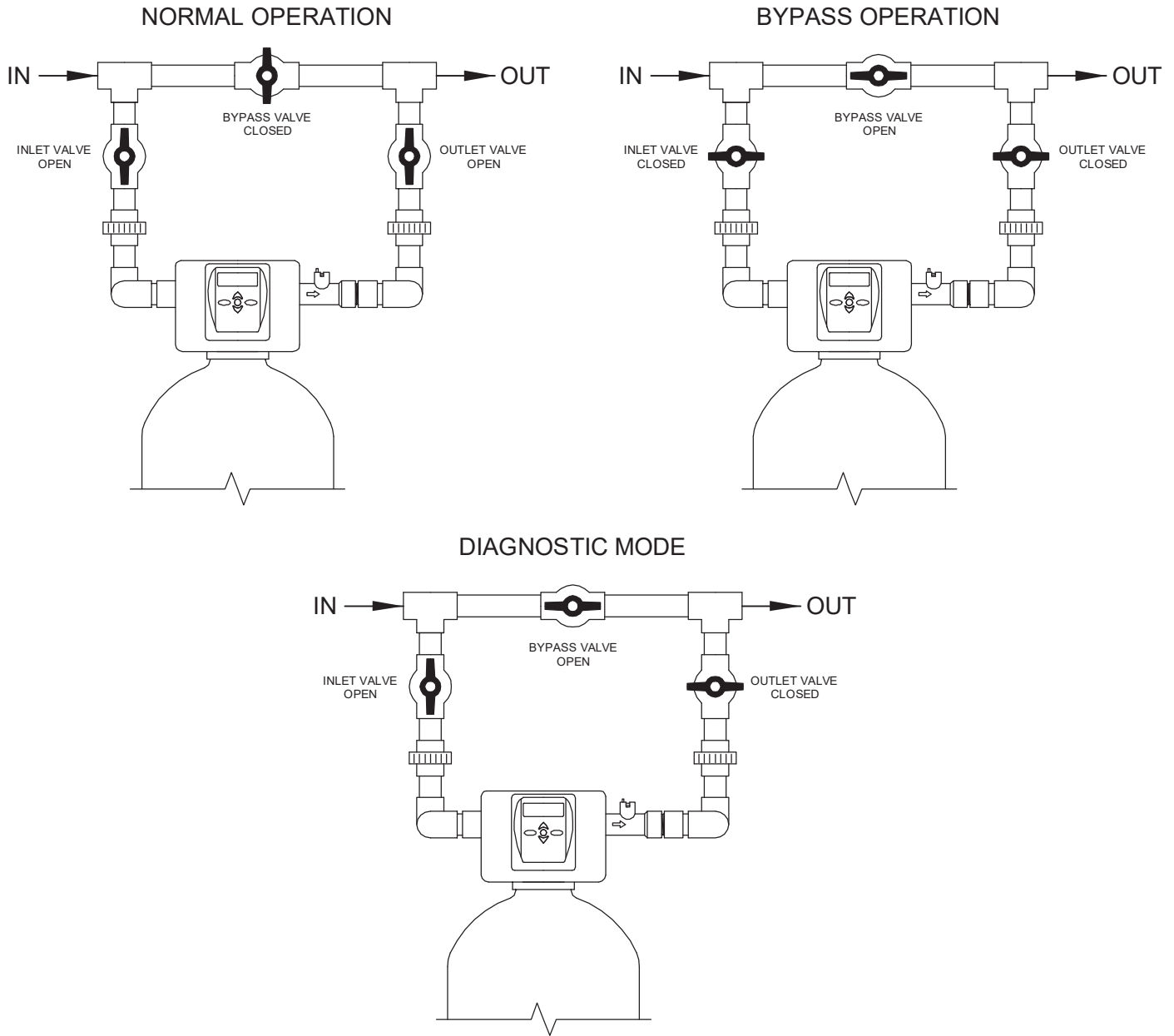

Normal Operation: Water flows through the control valve during service and also allows the control valve to isolate the media bed during the regeneration cycle.

Bypass Operation: The control valve is isolated from the water pressure contained in the plumbing system. Untreated water is supplied to the plumbing system.

Diagnostic Operation: Water pressure is allowed to the control valve and the plumbing system while not allowing water to exit from the control valve to the plumbing system.

INSTALLATION INSTRUCTIONS

(All electrical & plumbing should be done in accordance to all local codes)

1. LOCATION: Place the softener where you want to install it, making sure it is on a clean, level and firm surface. The plug-in power adaptor is for dry locations only. Use an uninterrupted electrical outlet installed within 15 feet of the softener. Locate the softener so the distance between the drain and the softener is as short as possible. Brine tank should be easily accessible. Do not install the softener with less than 10 feet of piping between its outlet and the inlet of a water heater. Do not locate the softener where it or its connections (including the drain and overflow lines) will ever be subject to room temperatures under 40°F.

2. INLET/OUTLET: Connect to a supply line downstream of outdoor spigots. Install an inlet shutoff valve and plumb to the unit's inlet located at the left front as you face the unit. Installation of a bypass valve is recommended. If using plastic fittings ground the water conditioner per local electric codes. If a water meter is used, install the water meter on the outlet side of the control valve. It is recommended that the meter assembly be installed horizontally or in a downflow vertical position to reduce turbine bearing wear. The turbine assembly may be oriented in any direction, but is usually oriented pointing up to reduce drainage out of the pipes during service. Remove the cover and drive bracket and thread the water meter cord through the hole in the back plate. Reinstall the drive bracket. Weave the cord through the hooks on the right hand side of the drive bracket and connect the end to the three prong connector labeled METER on the printed circuit board. Replace the cover.

3. A jumper ground wire should be installed between the inlet and outlet pipe whenever the metallic continuity of a water distribution piping system is interrupted. Install grounding strap on metal pipes.

4. DRAIN: The drain must be able to handle the backwash rate of the softener. Correctly size the drain line for the softeners drain line flow control gpm rating. An adapter fitting is supplied with the valve that can connect a 3/4" fitting to be used with drain line flow controls up to 10 gpm, a 1" fitting to be used with drain line flow controls up to 25 gpm, or a 1-1/2" fitting to be used with drain line flow controls up to 50 gpm. If soldering, joints near the drain must be done prior to connecting the drain line flow control fitting. Leave at least 6" between the drain line control fitting and solder joints when soldering pipes that are connected on the drain line control fitting. Failure to do this could cause interior damage to the drain line flow control fitting. Avoid elevating the drain line above the control valve where possible. **Never insert a drain line directly into a drain, sewer line, or trap. Always allow an air gap between the drain line and the wastewater receptacle to prevent the possibility of sewage being back-siphoned into the softener.**

5. REGENERATION: The brine refill flow control assembly is installed in an easy to access refill elbow located on the control valve. The LX15 series refill flow control assembly is attached to the 1.5" control valve with a locking clip. The locking clip allows the elbow to rotate 270 degrees so the outlet can be oriented towards the brine tank. The LX2 and LX2QC series refill flow control assembly is attached to the 2" control valve with a V3151 nut. Connect the brine line polytubing found with the brine tank to the brine connection on the control valve. The 1.5" control valve has a standard refill elbow to which a 1/2" flexible tube can be connected, see below. One polytube insert is shipped on the brine line elbow's locking clip. Remove this white polytube insert and replace the locking clip. The second polytube insert is taped to the top of the brine well cap in the brine tank. Press the polytube inserts into each end of the provided brine tubing, press the polytube with insert into the nut on the brine fitting. Tighten nut securely to create a pressure tight connection. The nut, gripper and retainer sleeve is a three-piece assembly that can come apart from the elbow body. Parts must be reassembled exactly as shown to function properly. If the nut is completely removed from the body, slip the nut, plastic gripper and retainer sleeve on to the tube then tighten on to the fitting.

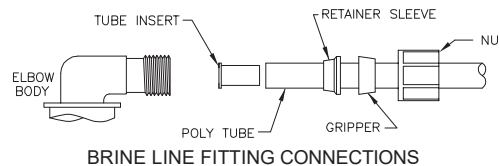

Note that 1/2" O. D. brine tube runs longer than 6 feet may restrict draw rates for LX15 series softeners using 21" or larger diameter mineral tanks. Locate brine tank as close as possible to softener. Increase brine tubing size to 5/8" O. D. if necessary. Make sure the floor is clean beneath the brine tank and that it is level and smooth. Install brine tubing to the brine tank using the above instructions. **The LX2 and LX2QC Series 2" control valves have a 1" PVC refill elbow connection (fitting kits available for 1/2" and 5/8" O. D. tubing connections); use 1" pipe to connect brine tank to 2" control valves for 30" or larger diameter mineral tanks.**

6. OVERFLOW: A 1/2" (inside diameter, not provided) gravity drain line should be connected to the overflow fitting on the side of the brine tank. This overflow is in case of a malfunction in the brine shut off. If the unit is installed where water may flow in the event of an overflow and cause water damage, connect a length of flexible tubing and run to a drain below the level of the overflow. **(Do not connect the tubing to the drain line on the control valve. Do not run tubing above overflow height at any point. Provide air gap.)**

Series LX15 LXCV15 Control Valve

Specific model overall dimensions are available- Consult factory.

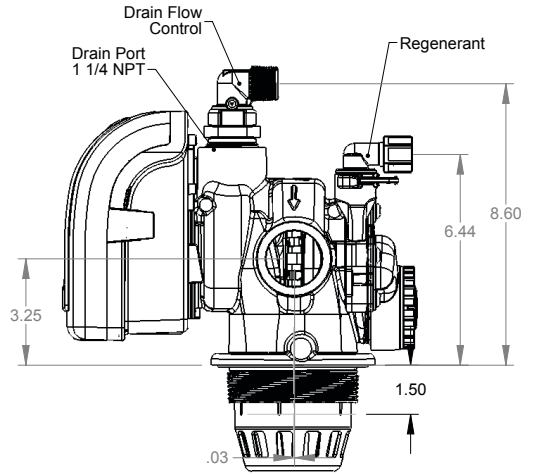
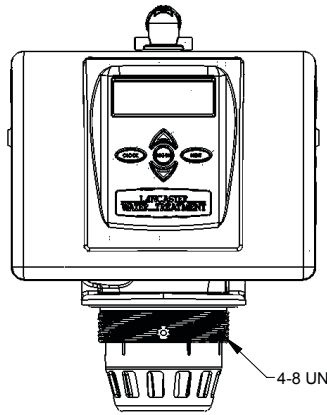
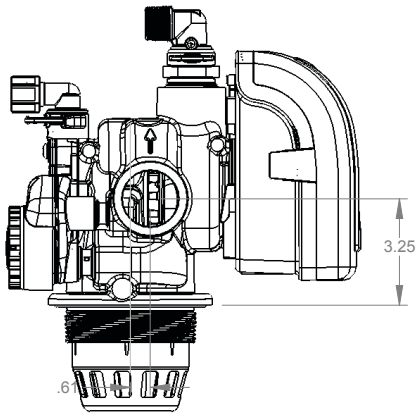
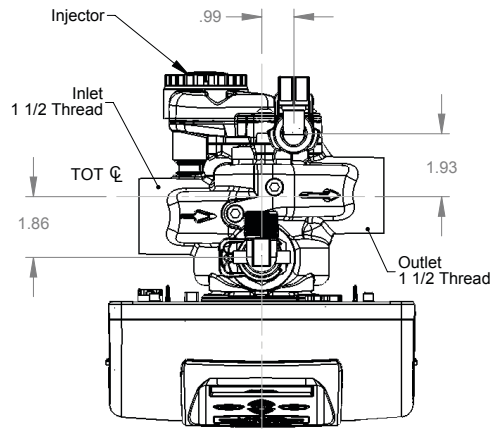

Series LX2 LXCV2 Control Valve

Specific model overall dimensions are available- Consult factory.

Note: Series LX2QC uses LXCV2QC Quick Connect control valve (not shown). Dimensions are available- Consult factory.

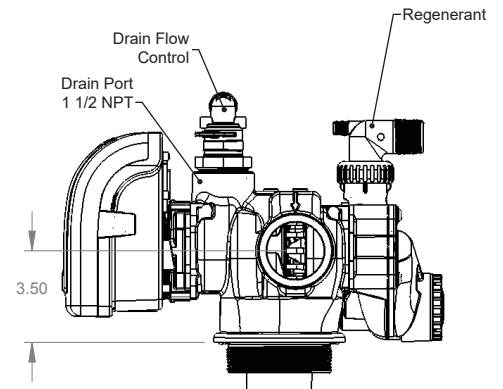
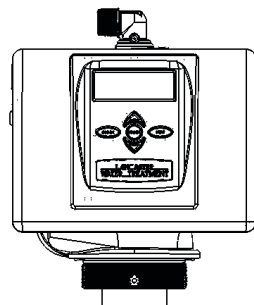
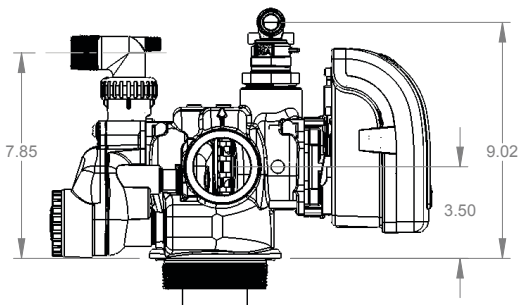
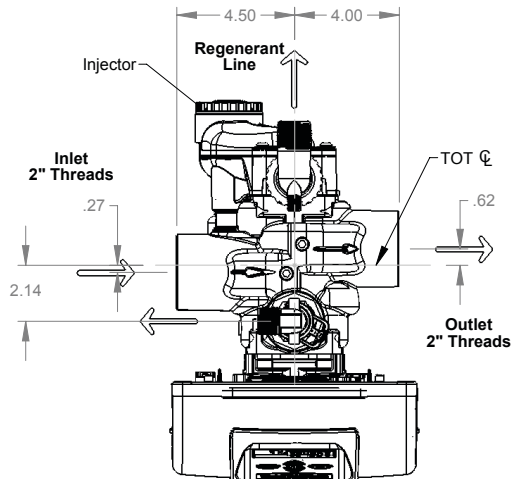

TYPICAL SINGLE SYSTEM INSTALLATION DIAGRAM

SINGLE: ONE WATER SOFTENER WITH METER, ONE BRINE TANK.

REGENERATION INITIATION CHOICES: METER IMMEDIATE, METER DELAYED, METER DELAYED + IMMEDIATE, DAYS OVERRIDE (1-28), AUXILIARY INPUT (SEE CUSTOM PROGRAMMING AND APPLICATION MANUAL).

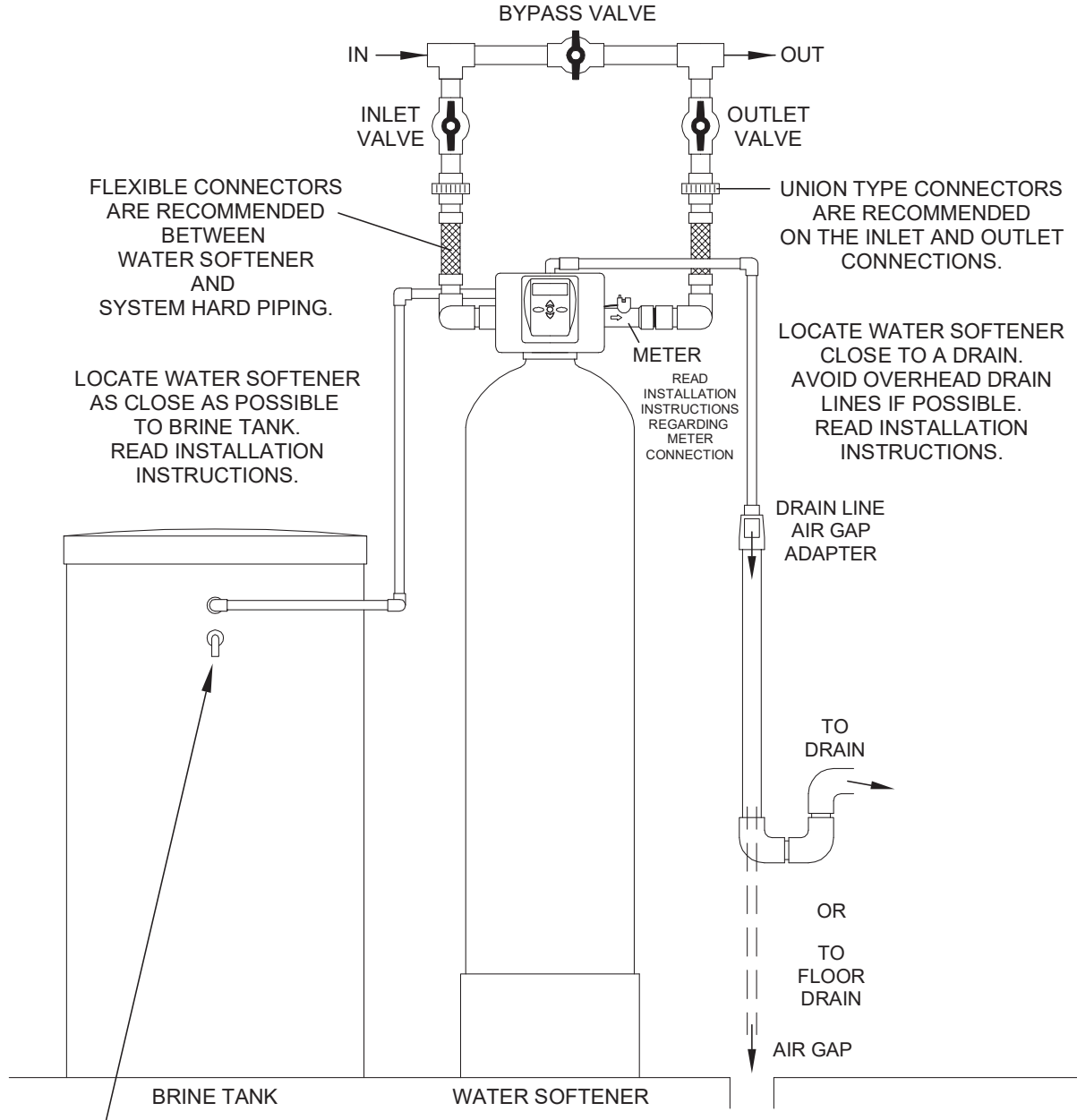

OVERFLOW GRAVITY DRAIN - ONLY USED IN CASE OF MALFUNCTION IN THE BRINE SHUTOFF. DO NOT CONNECT TO CONTROL VALVE DRAIN LINE. IF UNIT IS INSTALLED WHERE OVERFLOW COULD CAUSE WATER DAMAGE, CONNECT TUBING AND RUN TO FLOOR DRAIN. DO NOT RUN TUBING ABOVE OVERFLOW HEIGHT. READ INSTALLATION INSTRUCTIONS.

TOP VIEW
WITH OPTIONAL NO HARD
WATER BYPASS VALVE SHOWN

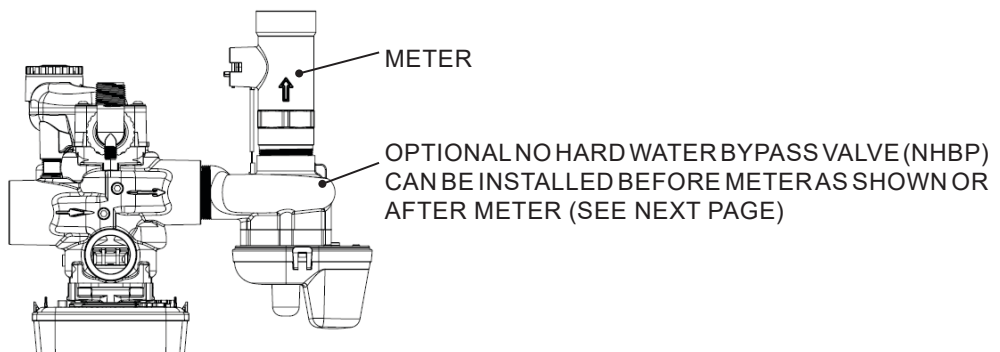

TYPICAL TWIN PARALLEL SYSTEM INSTALLATION DIAGRAM

TWIN PARALLEL: TWO IDENTICAL SOFTENERS, EACH WITH ITS OWN METER, ONLY ONE BRINE TANK.
 METER DELAYED REGENERATION USED WITH OFFSET REGENERATION TIMES.
 BOTH WATER SOFTENERS ARE ONLINE FOR DOUBLE THE SERVICE FLOW RATE AND EXCHANGE CAPACITY OF A SINGLE WATER SOFTENER.

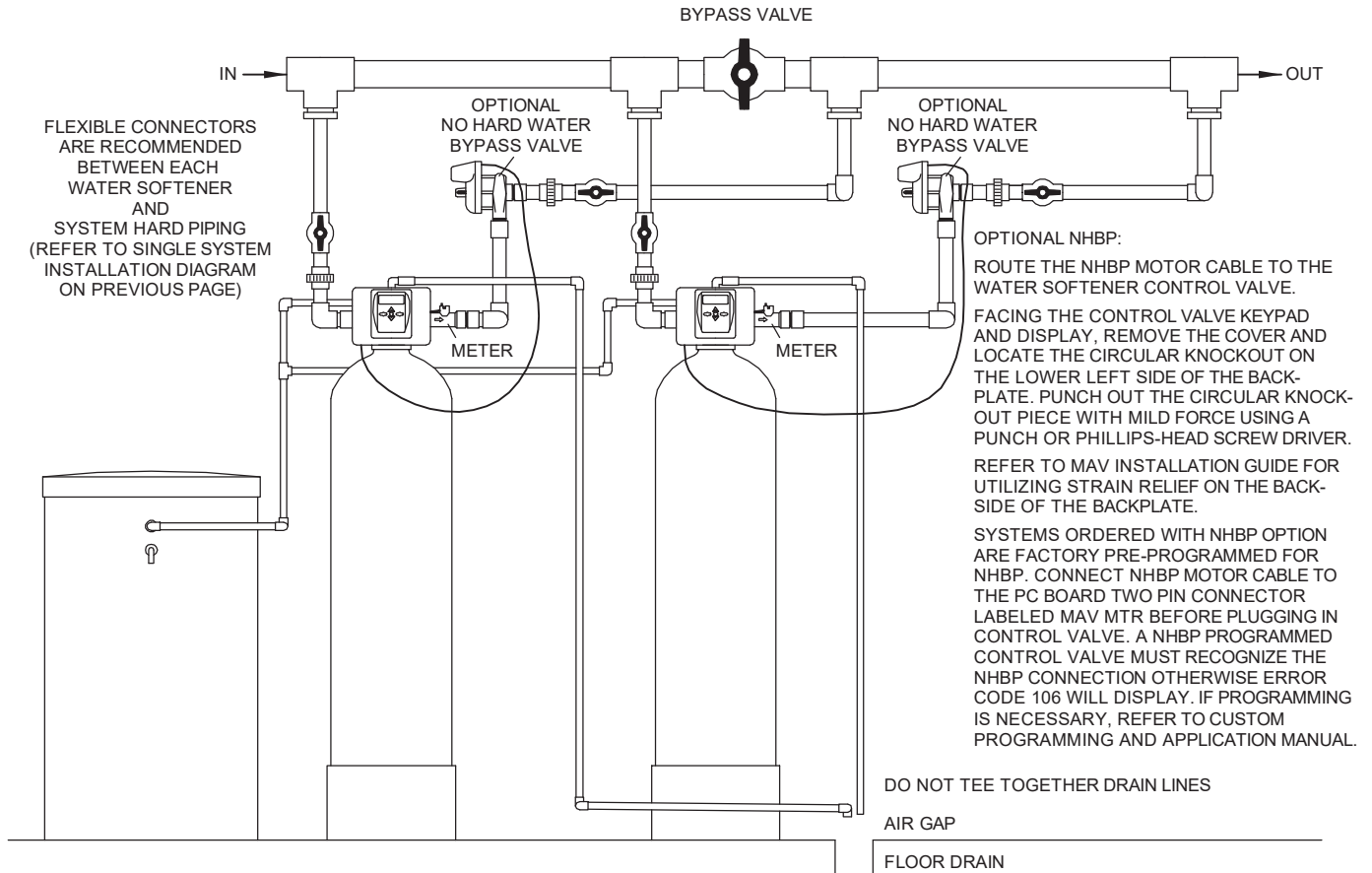

TYPICAL TWIN ALTERNATOR SYSTEM INSTALLATION DIAGRAM

TWIN ALTERNATING: TWO IDENTICAL SOFTENERS, ONLY ONE METER AND BRINE TANK, AND ONE MOTORIZED ALTERNATING VALVE (MAV).
 METER IMMEDIATE REGENERATION WITH HARD WATER USED.
 ONE SOFTENER ONLINE, ONE SOFTENER ON STANDBY.

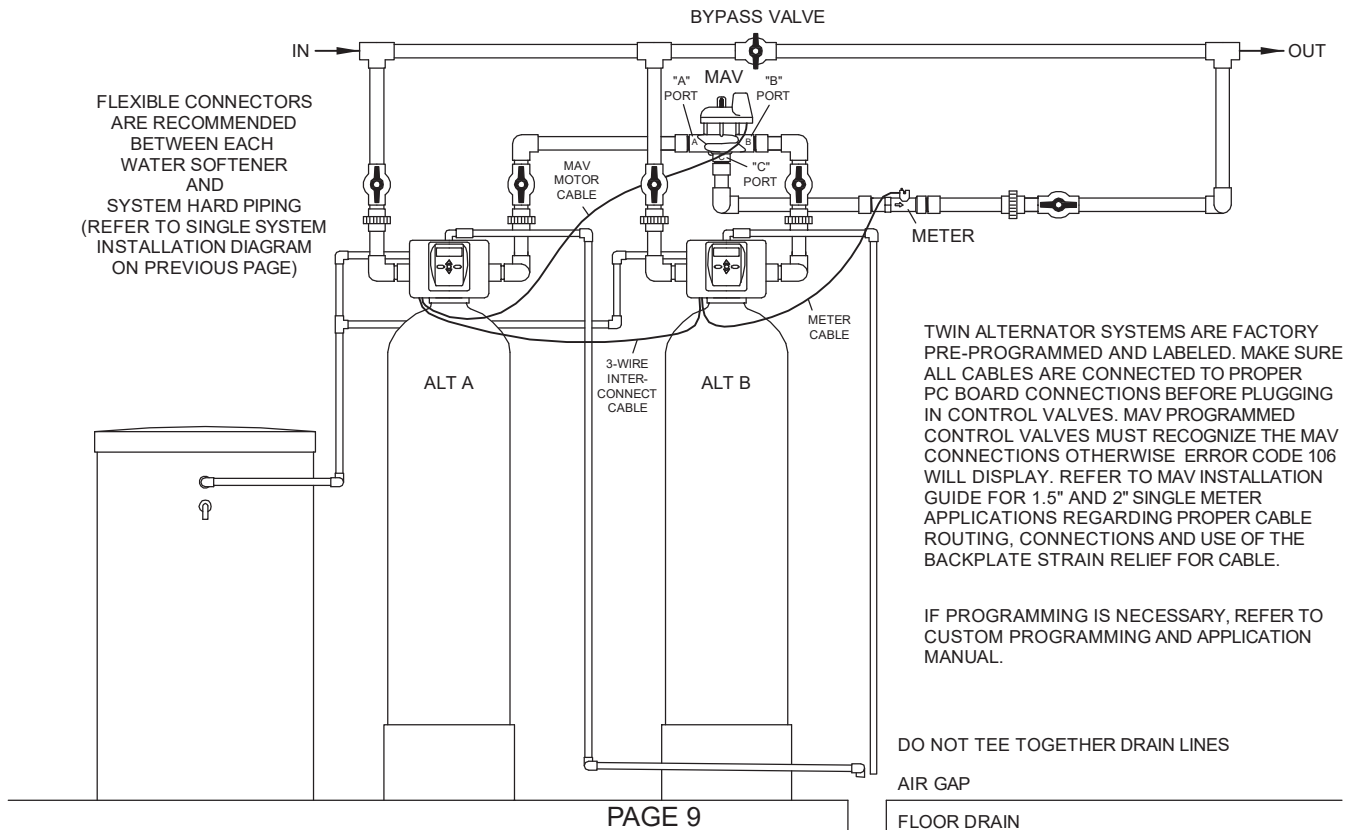

PLACING SOFTENER INTO SERVICE

Do not add salt to the brine tank yet. Do not plug the transformer into the receptacle yet. Make sure inlet and outlet valves are to their closed positions. If using optional bypass, open bypass valve. Turn on main water supply. Open a cold water faucet. This will clear the line of any debris (solder, pipe dope, etc.) that may be in the line. Let water run at faucet for a couple minutes, or until clear. Turn off faucet. Manually pour enough water into the brine tank to reach the top of the air check valve located at the bottom of the brine valve assembly in the white brine well. Now plug the transformer into a 120 volt receptacle (be certain the receptacle is uninterrupted). Within 5 seconds the control display and buttons will illuminate and the time of day screen will appear.

- Press and hold the **REGEN** button for approximately 5 seconds until the motor starts.
- Wait until display reads **BACKWASH** and numbers start counting down.
- Momentarily press **REGEN** again. Valve is now in the **REGENERANT DRAW** position.
- Momentarily press **REGEN** again. Valve is now in the second **BACKWASH** position.

SLOWLY open inlet valve to **DIAGNOSTIC** mode (See page 5) to allow water to slowly fill Softener and expel air.

CAUTION: If water flows too rapidly, there could be a loss of resin out of the drain.

When water is flowing steadily to drain without the presence of air, momentarily press **REGEN** again. Display will read **RINSE**. Close the bypass valve and open the outlet valve of the softener, for **NORMAL OPERATION** (see page 5). Allow control to finish the **RINSE** cycle. It will then advance to the **FILL** position. The brine tank will now automatically fill with the proper volume of water for the first regeneration. Allow the control to automatically advance to the **SOFTENING** position. Now load the brine tank with salt. Solar Salt is recommended. The brine tank salt level should be checked every couple of weeks to determine salt usage. Keeping the brine tank salt level at least 1/2 full is recommended.

SANITIZING: Use 2 oz. of 5 1/4% unscented household chlorine bleach for each cubic foot of resin. Pour bleach directly into the white brine well located inside the brine tank. Press and hold the **REGEN** for 5 - 6 seconds until the motor starts running. Allow system to complete the regeneration automatically. Check for other local and state codes which may also specify sanitation methods.

GENERAL OPERATION

Note: As an energy saving feature, the control will automatically turn off all **SOLID BLUE** or **SOLID GREEN** display illumination and keypad illumination after about 5 minutes of the last keypad button push. Any further keypad touch will cause the re-illumination of the display and keypad, and re-activate keypad control.

User Displays

When the system is in normal service mode, one of up to five available User Displays will be shown. Pressing **NEXT** will alternate between the following displays:

- Current time of day
- Treated water flow rate
- Service contact name and phone number (if entered)
- Remaining Capacity of treated water available
- Remaining days to regeneration (if Day Override is programmed)

Pressing the **▽** button while in the Capacity Remaining or Days Remaining displays will decrease the capacity remaining in ten gallon increments or the days remaining in one day increments.

To clear the Service Call reminder, press the **△** and **▽** buttons simultaneously while the number and banner text screen is displayed.

If the system has called for a regeneration that will occur at the preset time of regeneration, the words **REGEN TODAY** will alternate with the header on the display.

Utilizing the control valve's built-in water meter, a water drop flashes on the display when water is being treated (i.e. water is flowing through the system).

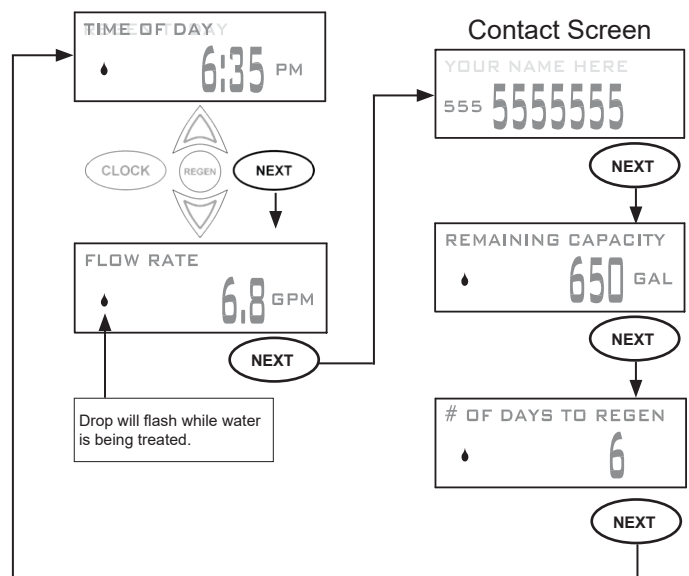

SET TIME OF DAY

Current time of day needs to be entered during initial installation, and adjusted when daylight saving time begins or ends. If an extended power outage occurs and depletes the on-board non-rechargeable coin cell battery, when power resumes the time of day should be reset and battery replaced.

STEP 1 **STEP 1** – Press **CLOCK**



STEP 2 **STEP 2** - Current Time (hour): Set the hour of the day using **▲** or **▼** buttons. AM/PM toggles after 12. Press **NEXT** to go to Step 3.



STEP 3 **STEP 3** - Current Time (minutes): Set the minutes of the day using **▲** or **▼** buttons. Press **NEXT** to exit Set Time of Day. Press **REGEN** to return to previous step.



RETURN TO NORMAL MODE



ADJUST HARDNESS, DAYS BETWEEN REGENERATIONS, OR TIME OF REGENERATION

STEP 1 **STEP 1** - Press **NEXT** and **▲** simultaneously for 3 seconds to access Installer Display Settings.



STEP 2 **STEP 2** – Hardness: Set the amount of hardness in grains of hardness as calcium carbonate per gallon using the **▲** or **▼** buttons. The default is 20 with value ranges from 1 to 150 in 1 grain increments. Note: The grains per gallon can be increased if soluble iron needs to be reduced. Press **NEXT** to go to step 3. Press **REGEN** to exit Installer Display Settings.





STEP 3 **STEP 3** – Day Override: Set the maximum number of days between regenerations. If value set to “OFF”, regeneration initiation is based solely on volume used. If value is set as a number (allowable range from 1 to 28) a regeneration initiation will be called for on that day even if sufficient volume of water were not used to call for a regeneration. Set Day Override using **▲** or **▼** buttons:

- number of days between regeneration (1 to 28); or
- “OFF”.

Press **NEXT** to go to step 4. Press **REGEN** to return to previous step.



STEP 4 **STEP 4** – Next Regeneration Time (hour): Set the hour of day for regeneration using **▲** or **▼** buttons. AM/PM toggles after 12. The default time is 2:00 AM. Press **NEXT** to go to Step 5. Press **REGEN** to return to previous step.



STEP 5 – Next Regeneration Time (minutes): Set the minutes of day for regeneration using or buttons. Press to return to normal operation. Press to return to previous step.

RETURN TO NORMAL MODE

LOW BATTERY

A non-rechargeable coin cell battery is located on the circuit board, used only to maintain the time of day during power outages (all other information will be stored in memory no matter how long the power outage). The screen displays LOW BATTERY when the battery needs to be replaced. The screen will remain illuminated solid blue when LOW BATTERY is displayed. Initially LOW BATTERY display will alternate with the User display, finally displaying only LOW BATTERY. User displays are still accessible by pressing .

CONTACT SCREEN PROGRAMMING

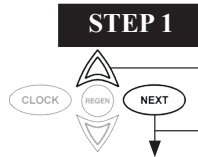

STEP 1 - Press and simultaneously for 3 seconds to access Installer Display Settings.



STEP 2 - Press to go to step 3.



STEP 3 - Press to go to step 4.

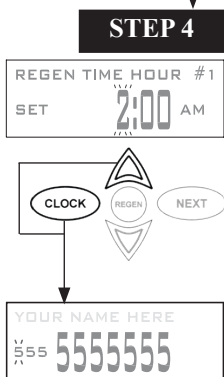

From Step 4, while hour is flashing, press and hold both the and button to change phone number and banner text.

Phone Number - Set phone number using the or arrow. Press to forward to the next digit. Press to return to previous digit.

Banner Text - Set the banner text up to a maximum of 44 characters. Use the or to select letters of the alphabet, numbers, ampersand (&), or a space in the banner text. Press to forward to the next character or to exit the Installer Display Settings.

X-FACTOR COMMERCIAL SERIES GENERAL SPECIFICATIONS

Operating Pressure; Min to Max (PSI)	20 to 125
CAUTION: the softener cannot be subject to a vacuum due to loss of pressure (such as a water main break or submersible well pump check valve failure).	
Water Operating Temp; Min to Max (°F)	40 to 110
CAUTION: do not locate the softener where it or its connections (including the drain line and overflow lines) will ever be subject to room temperatures under 40°F	
AC Adaptor Input; Voltage - Hertz	120V AC - 60 Hz
AC Adaptor Output; Voltage - Current	12V AC - 500 mA
3 Volt Lithium Coin Cell Battery; type	2032
PC Board Relay Terminal Block DC Output; Voltage	12V DC **
** Relay Specifications: 12V DC Relay with a coil resistance not less than 80 ohms. If mounting the relay under the control valve cover, check for proper mounting location dimensions on the backplate.	
No user serviceable parts are on the PC board, motor, or the Power adapter. The means of disconnection from the main power supply is by unplugging the Power adapter from the wall.	
Control Valve; Inlet/Outlet/ Drain Port NPT size	See page 7
Meter Accuracy	± 5%
Meter Flow Range	1.5": 0.5-75 gpm, 2": 1.5-150 gpm
Compatible with the following typical concentrations of regenerants	Sodium chloride, potassium chloride

SPECIFIC MODEL # SPECIFICATIONS ARE AVAILABLE. PLEASE CONSULT FACTORY.

CONTROL VALVE, METER AND BRINE VALVE ASSEMBLY PARTS DIAGRAMS ON NEXT PAGES.

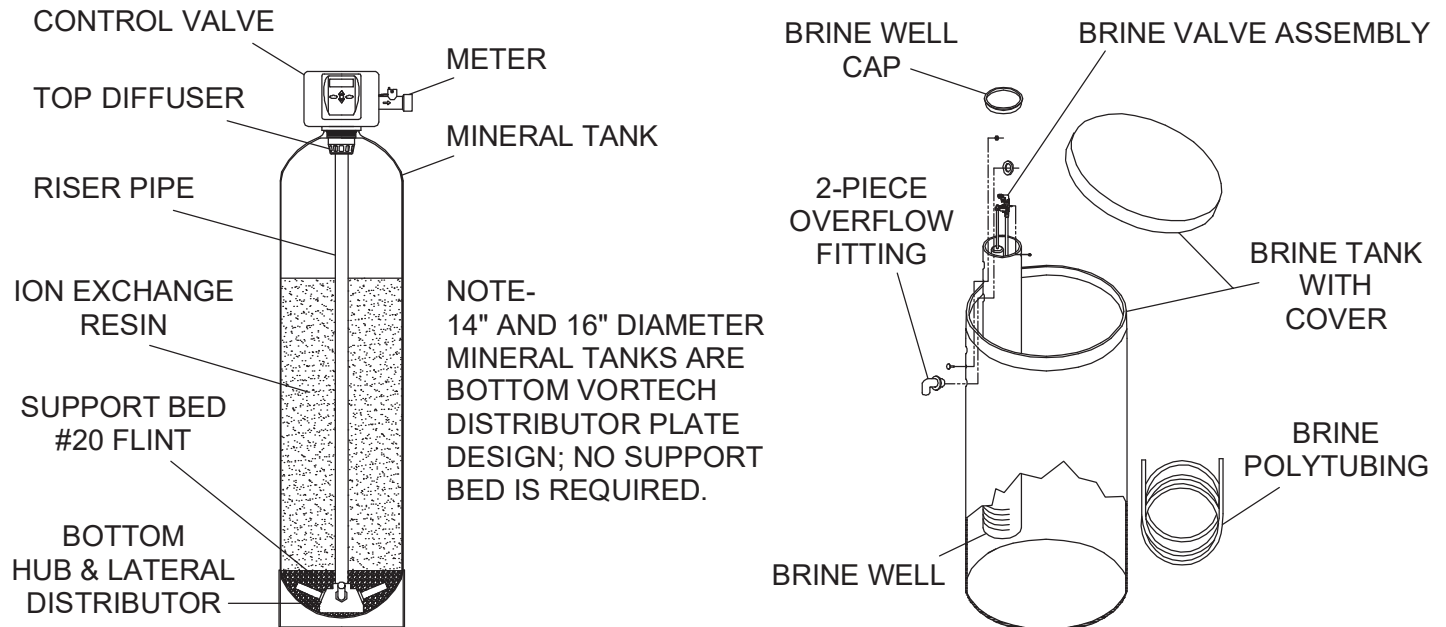

4740 BRINE VALVE ASSEMBLY

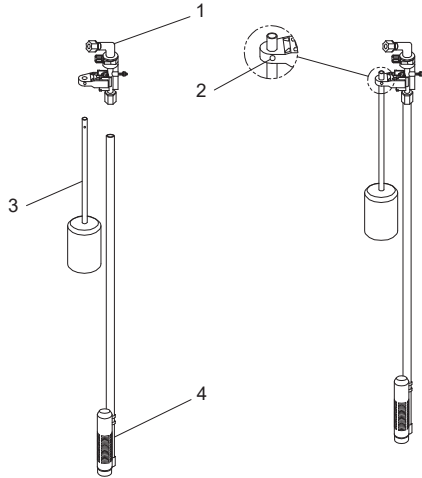

FOR MODELS

LX15-90 thru LX15-300

LX2-120 thru LX2-300

LX2QC-120 thru LX2QC-300

Drawing No.	Order No.	Description	Quantity
1	H4600 with H4650	Safety Brine Valve with 1/2" Elbow & Polytube Insert	1
2	10151	Pin	1
3	H4640-9.5	Float Assembly	1
4	H4500-48	Air Check Assembly (uncut length) 1/2" x 48"	1

494 1" COMMERCIAL BRINE VALVE ASSEMBLY

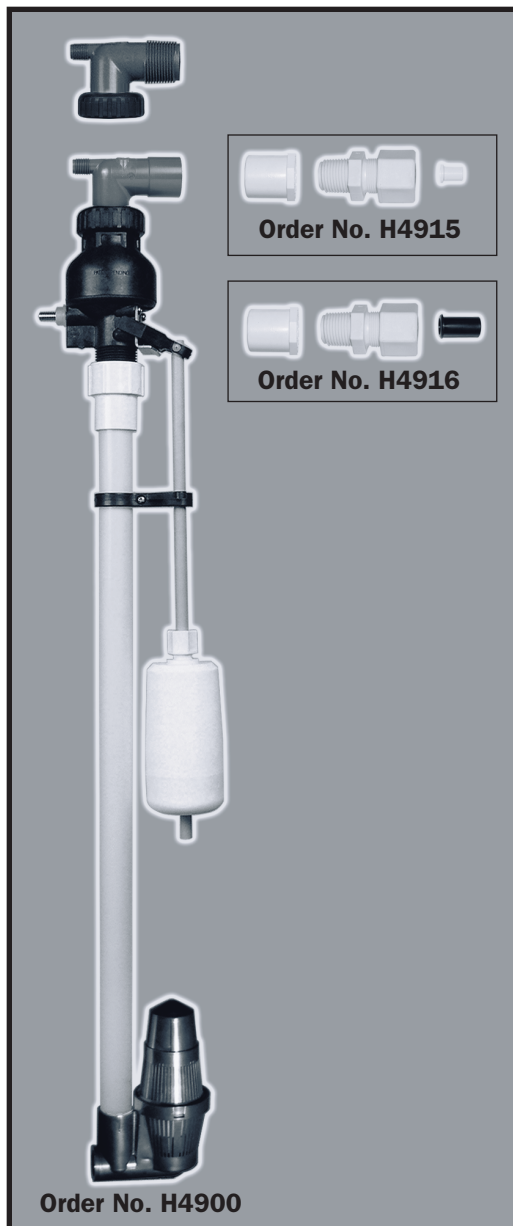

FOR MODELS

LX2-450 thru LX2-1200

LX2QC-450 thru LX2QC-1200

Order No.	Description	Quantity
H4900	494 1" Brine Valve, Float Assembly, Air Check, and 60" Riser	1
H4915	Fitting Kit 494 Brine Valve 1/2" Polytube Connection	1
H4916	Fitting Kit 494 Brine Valve 5/8" Polytube Connection	1

H4900 includes the brine valve, two brine connection elbows (1" PVC male NPT and 3/4 x 1" PVC solvent) adjustable float, air check assembly with 60" riser, 1" riser adapter and float rod guide.

X-FACTOR FRONT COVER AND DRIVE ASSEMBLY

Drawing No.	Order No.	Description	Quantity
1	V3692-02LW	LP Front Cover Assembly	1
2	V3107-01	Motor	1
3	V3106-01	Drive Bracket & Spring Clip	1
4	V3757LP-BOARD	PC Board	1
5	V3110	Drive Gear 12x36	3
6	V3109	Drive Gear Cover	1

When replacing the battery, align positives and push down to fully seat.

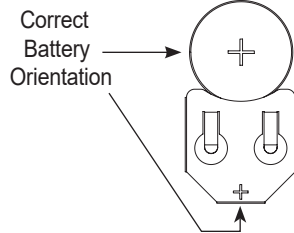
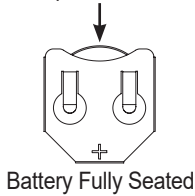

Battery replacement is 3 volt lithium coin cell type 2032.

AC Adapter	(Not shown)
Order No.	V3186
Supply Voltage	120V AC
Supply Frequency	60 Hz
Output Voltage	12V AC
Output Current	500 mA

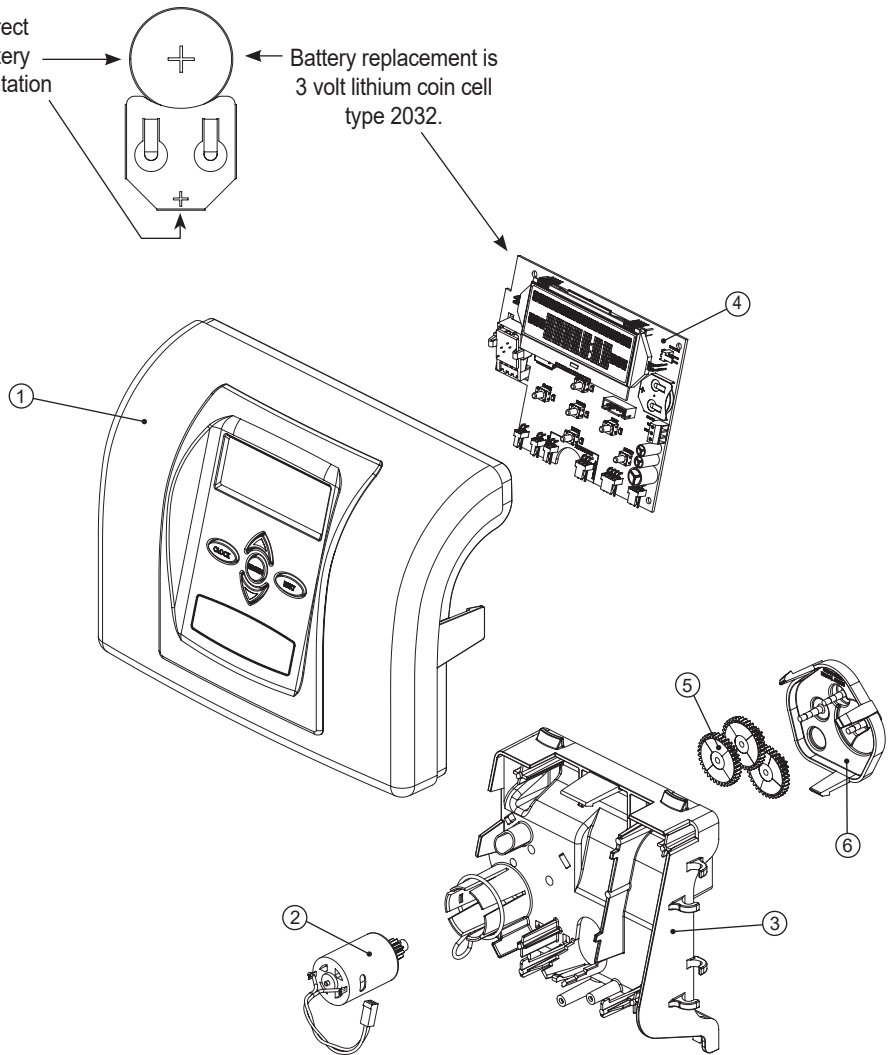

After completing any valve maintenance involving the drive assembly or the drive cap assembly and pistons, unplug power source jack from the printed circuit board (black wire) and plug back in or press and hold **NEXT** and **REGEN** buttons for 3 seconds. This resets the electronics and establishes the service piston position. The display should flash the software version and then reset the valve to the service position.

LX15 SERIES

LXCV15 Control Valve Drive Cap Assembly, Downflow Piston, Regenerant Piston, Spacer Stack Assembly and Main Body

Drawing No.	Order No.	Description	Quantity
1	V3004	Drive Cap Assembly	1
2	V3135	O-ring 228	1
3	V3407	Piston Downflow Assembly	1
4	V3174	Regenerant Piston	1
5	V3423	Backplate Dowel	1
6	V3430	Spacer Stack Assembly	1
7	V3178LP	Back Plate	1
8	V3419	O-ring 347	1
9	V3641	O-ring 225 for valve bodies with NPT threads	1
10	V3950-01	1.5 NPT Valve Body, Gen 2	1
11	V3468	Test Port Plug, 1/4" NPT	2
12	D1300	Top Baffle Diffuser, 1.5/50MM	1

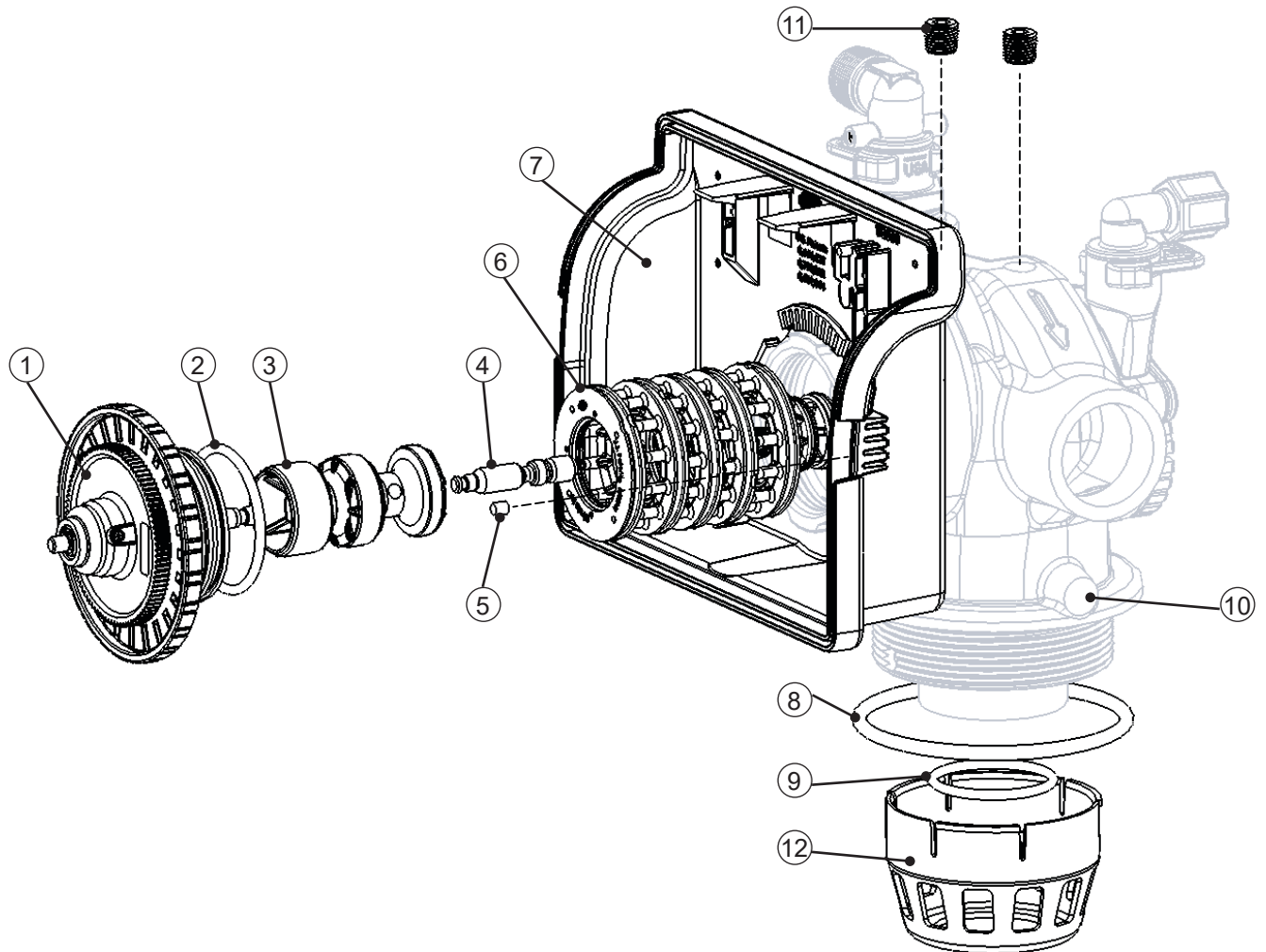

LX2 SERIES

LXCV2 Control Valve Drive Cap Assembly, Downflow Piston, Regenerant Piston, Spacer Stack Assembly and Main Body

Drawing No.	Order No.	Description	Quantity
1	V3726	Brine Piston Assembly	1
2	V3725	Piston Downflow Assembly	1
3	V3452	O-ring 230	1
4	V3728	Drive Cap Assembly	1
5	V3724	Washer Flat SS 1/4	4
6	V3642	Bolt BHCS S/S 1/4-20X1.25	4
7	V3178LP	Back Plate	1
8	V3729	Stack Assembly	1
9	V3419	O-ring 347	1
10	V3641	O-ring 225 for valve bodies with NPT threads	1
11	V3700-01	2 NPT Valve Body	1
12	V3468	Plug, 1/4" NPT	2
13	D1300	Top Baffle Diffuser, 1.5/50MM	1

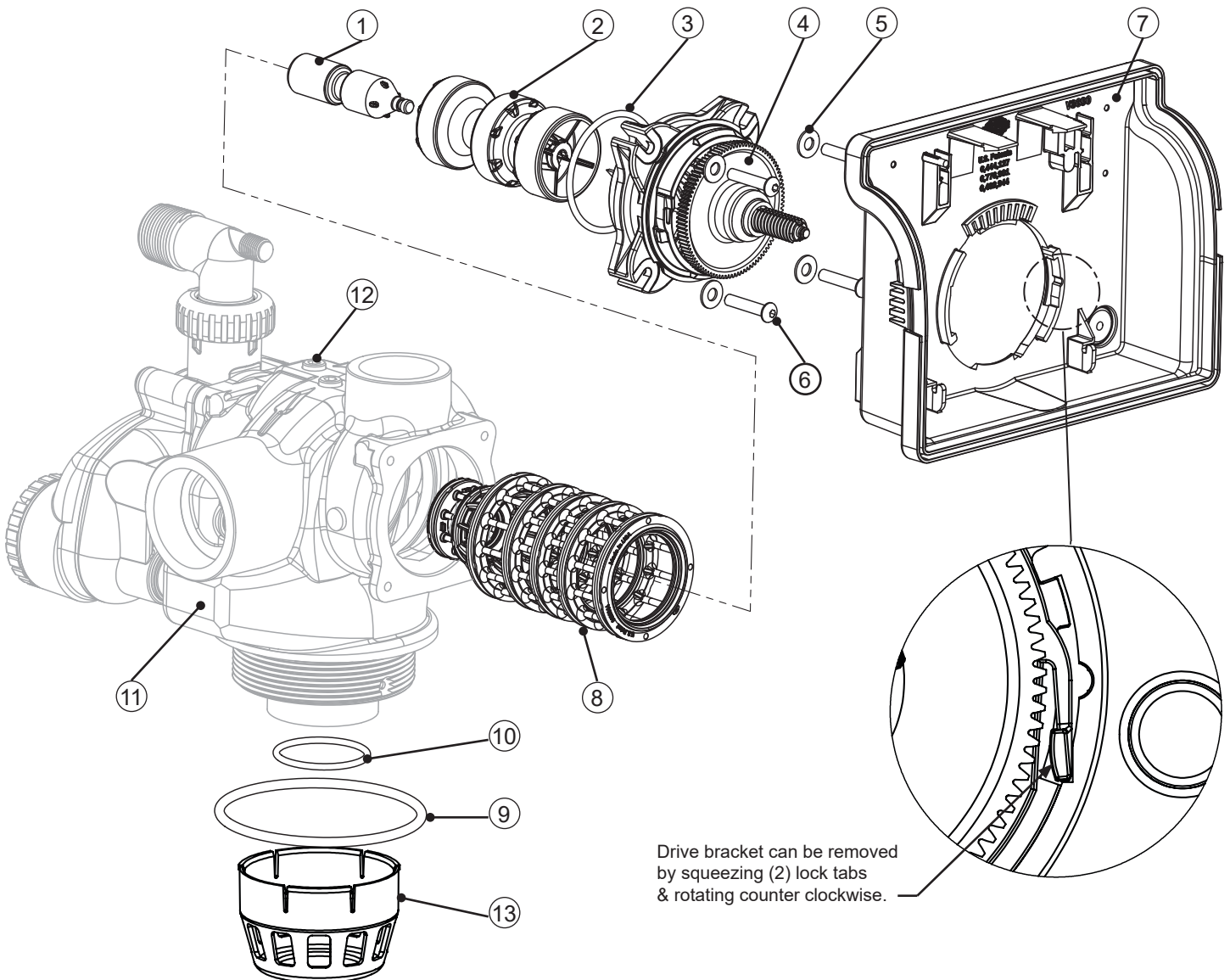

LX2QC SERIES

LXCV2QC Quick Connect Control Valve Drive Cap Assembly, Downflow Piston, Regenerant Piston, Spacer Stack Assembly and Main Body

Drawing No.	Order No.	Description	Quantity
1	V3726	Brine Piston Assembly	1
2	V3725	Piston Downflow Assembly	1
3	V3452	O-ring 230	1
4	V3728	Drive Cap Assembly	1
5	V3724	Washer Flat SS 1/4	4
6	V3642	Bolt BHCS S/S 1/4-20X1.25	4
7	V3178LP	Back Plate	1
8	V3729	Stack Assembly	1
9	V3279	O-ring 346	1
10	V3280	O-ring 332 for valve bodies with NPT threads	1
11	V3737-01	2 NPT QC Valve Body	1
12	V3054*	4IN Base Clamp Assembly	1
13	V3276	Bolt Hex 5/16 - 18 x 1-3/4	1
14	V3269	Nut 5/16 - 18 SS Hex	1
15	V3468	Plug, 1/4" NPT	2
Not Shown	D1300-01	Top Baffle Diffuser, 2/63MM	1

* V3054 4IN Base Clamp Assy includes a V3276 Bolt Hex 5/16 - 18 X 1-3/4 and V3269 Nut 5/16 - 18 SS Hex

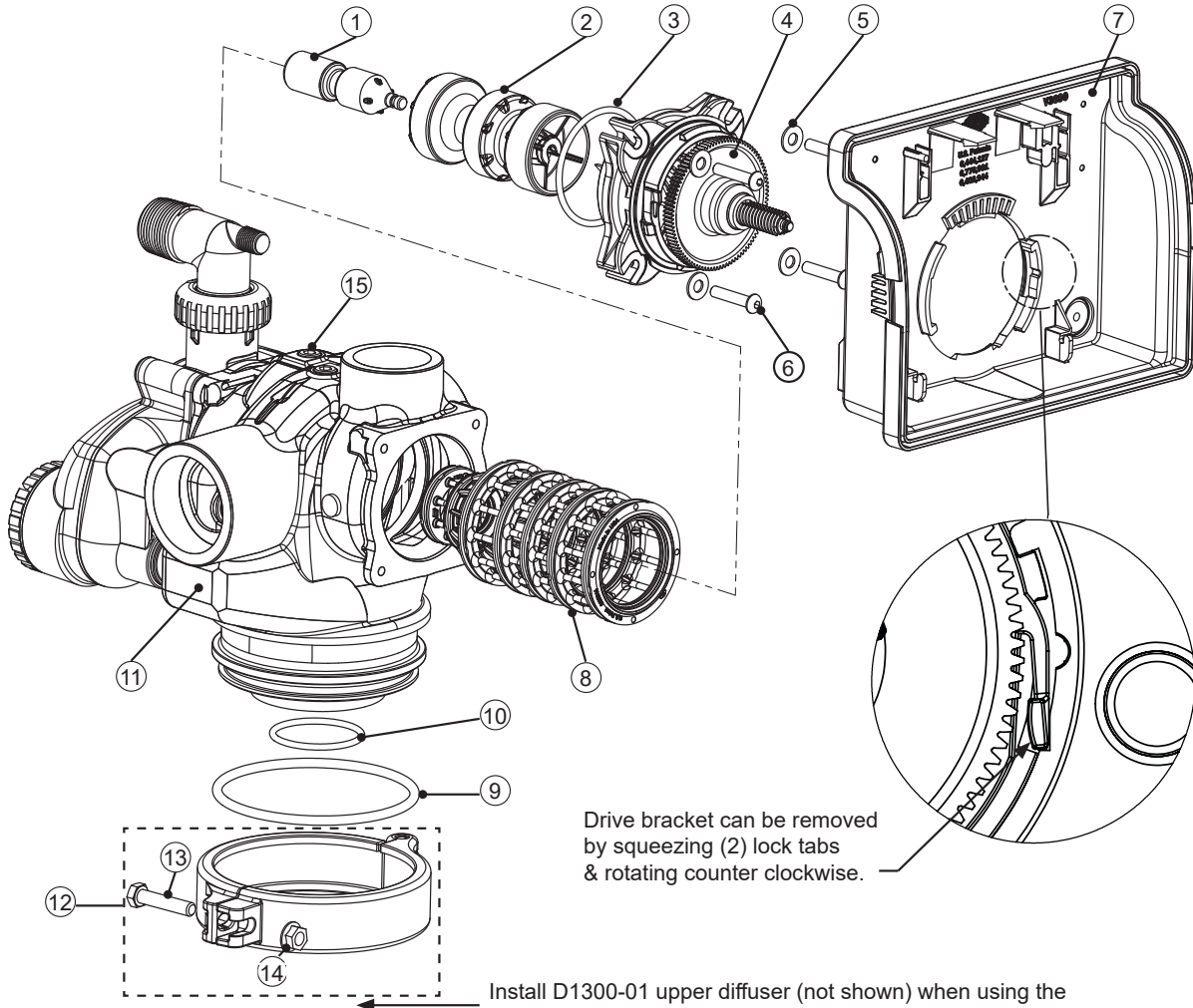

Drive bracket can be removed by squeezing (2) lock tabs & rotating counter clockwise.

Install D1300-01 upper diffuser (not shown) when using the 4" Quick Disconnect (V3064).

LX2QC SERIES

V3064 4 Inch Base Asy

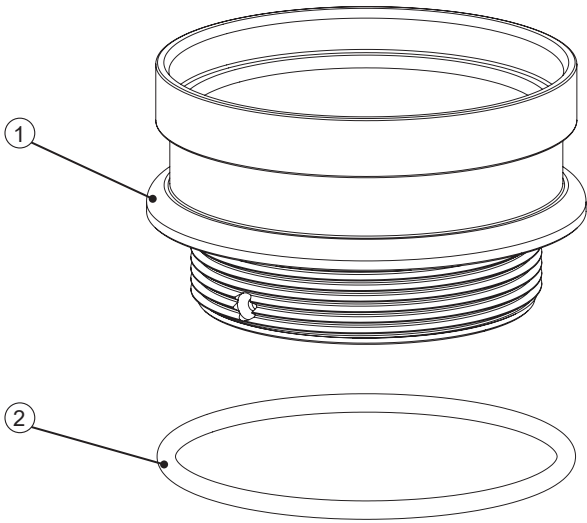

Drawing No.	Order No.	Description	Quantity
1	V3202-01	Base	1
2	V3281	O-Ring 348	1

V3055 Flange Base Asy

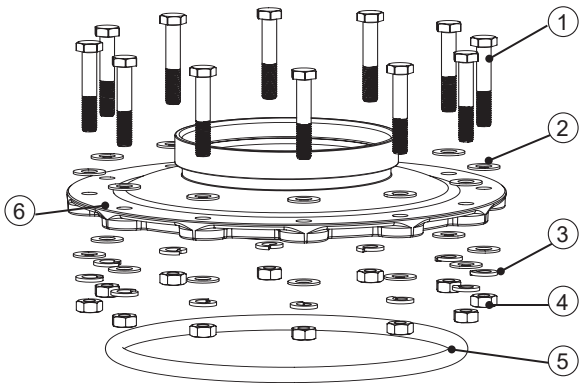

Drawing No.	Order No.	Description	Quantity
1	V3444	Screw Hexcap 5/16-18 x 2 SS	12
2	V3293	Washer SS 5/16 Flat	24
3	V3445	Washer Split Lock 5/16 SS	12
4	V3447	Nut Hex 5/16-18 Full SS	12
5	COR60FL	O Ring 6 Flange Adapter (Park)	1
6	V3261-01	Flange Base	1

V3260-02 Side Mount Base NPT

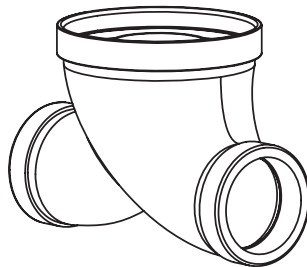

LX15 SERIES

LXCV15 Injector Valve Body, Refill Flow Control and Injector

Drawing No.	Order No.	Description	Quantity
1	V3967	Injector Body, Welded Assembly	1
2	V3441	O-ring -226	1
3	V3968***	Injector Feed Tube	1
4	V3177-01	Injector Screen	1
5	V3969****	Injector Draw Tube	1
6	V4349	Injector Cap (V3176 on valves prior to 4./5/2020)	1
7	V3152	O-ring -135	1
8	See page 22	Injector	1
9	V3498**	Refill Flow Control, 1/2"	1
10	V3428**	Refill Retainer Assembly (0.5 GPM)	1
11	V3163	O-ring, -019	1
12	H4612	Regenerant Elbow w/Flow Control	1
13	JCPG-8PBLK	Nut, Compression, 1/2" Black	1
14	JCP-P-8	Insert, Polytube 1/2"	1
15	V3182	Refill Flow Control (0.5 GPM)	1
16	H4615	Retaining Clip	1
17	V3724	Washer, Flat Stainless Steel	4
18	V3642	Bolt, BHCS Stainless Steel 1/4-20x 1 1/4	4
19	V3195-01	Refill Port Plug	1

** Contains a V3182 0.5 gpm flow control

*** V3968 contains one D1240 O-RING 111 and two V3155 O-RING 112

**** V3969 contains one V3638 O-RING 113 and two V3157 O-RING 115

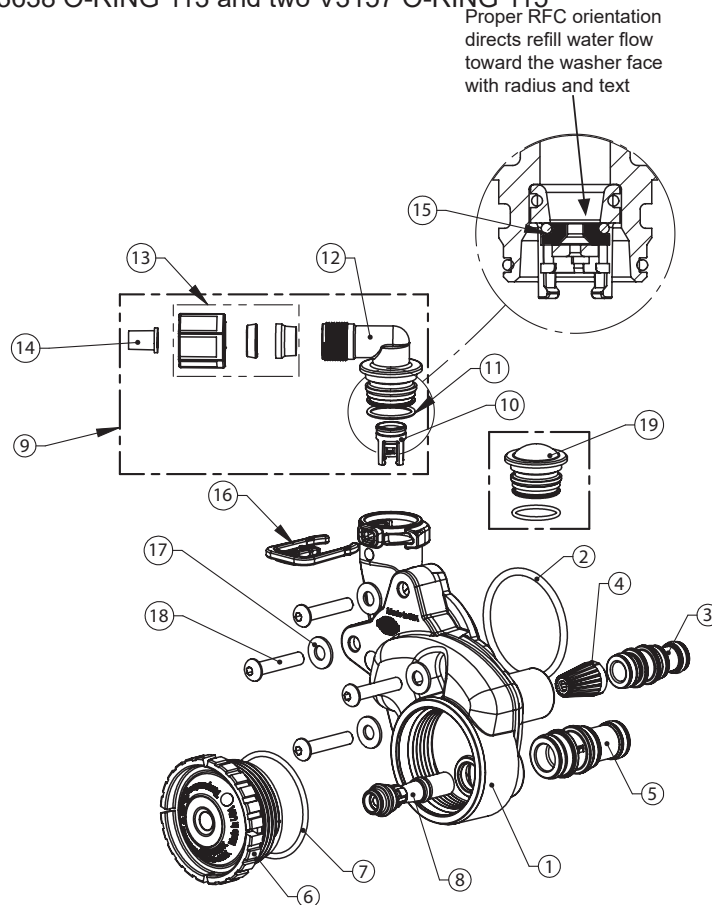

LX2 & LX2QC SERIES

LXCV2 & LXCV2QC Injector Valve Body, Refill Flow Control and Injector

Drawing No.	Order No.	Description	Quantity
1	V3477	Injector Cap	1
2	V3152	O-Ring 135	1
3	V3727	Injector Body Assembly	1
4	See page 22	Injector	1
5	V3731	Inj Draw Tube Down Assembly	1
6	V3730	Inj Feed Tube Down Assembly	1
7	V3315	O-Ring 231	1
8	V3724	Washer Flat SS 1/4	4
9	V3643	Bolt BHCS S/S 1/4-20x2.25	4
10	V3162-022	2.2 gpm flow control for Models LX2 & LX2QC - 120 thru 300	1
	V3162-053	5.3 gpm flow control for Models LX2&LX2QC - 450 thru 1200	1
11	V3231	Refill FLOWCNTRL Retainer	1
12	V3277	O-Ring 211	1
13	V3105	O-Ring 215	1
14	V3150	Split Ring	1
15	V3151	Nut 1 QC	1
16	V3149**	FTG 1 PVC Male NPT Elbow for Models LX2 & LX-2QC-450 thru 1200	1
Not Shown	V3189*	FTG 3/4&1 PVC SLVNT 90 for Models LX2 & LX-2QC-120 thru 300	1

* Use H4915 fitting kit for 1/2" O.D. polytube connection. If brine tube length exceeds 6 feet, use H4916 fitting kit for 5/8" polytube connection, increasing polytube size to 5/8" O.D. Refer to installation section.

** Use 1" pipe to connect to brine tank. Refer to installation section.

A V3731 INJ DRAW TUBE DOWN ASY contains one D1262 O-RING 118 and two V3639 O-RING 119.

A V3730 INJ FEED TUBE DOWN ASY contains three V3638 O-RING 113.

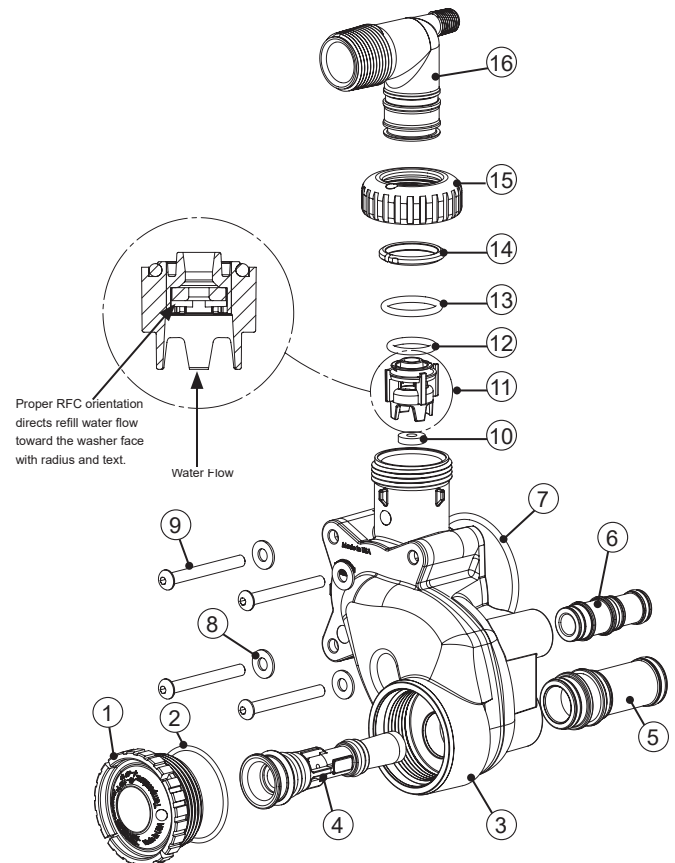

LXCV15(Gen 2) Injectors

Drawing No.	Order No.	Description	Nozzle Color	Typical Tank Diameter ¹	Quantity
1	V3010-15B	1.5 Injector Asy B	Violet	12"	1
	V3010-15C	1.5 Injector Asy C	Red	13"	
	V3010-15D	1.5 Injector Asy D	White	14"	
	V3010-15E	1.5 Injector Asy E	Blue	16"	
	V3010-15F	1.5 Injector Asy F	Yellow	18"	
	V3010-15G	1.5 Injector Asy G	Green	21"	
	V3010-15H	1.5 Injector Asy H	Orange	24"	
2	V3010-15Z	1.5 Injector Plug		NA	

The V3010-15X injector contains one V3416 O-RING 012 (lower) and one V3171 O-RING 013 (upper).

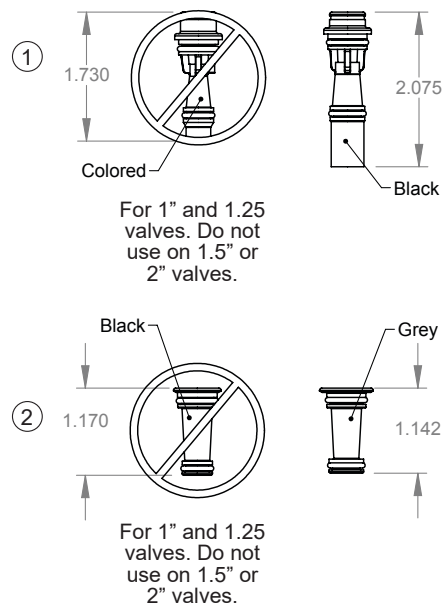

LXCV2 and LXCV2QC Injectors

Drawing No.	Order No.	Description	Nozzle Color	Typical Tank Diameter ¹	Quantity
Not Shown	V3010-2R-15B *	2" Injector Assembly, R, w/V3010-15B	Violet	12"	1
	V3010-2S-15C *	2" Injector Assembly, S, w/V3010-15C	Red	13"	
	V3010-2T-15D *	2" Injector Assembly, T, w/V3010-15D	White	14"	
	V3010-2U-15E *	2" Injector Assembly, U, w/V3010-15E	Blue	16"	
	V3010-2V-15F *	2" Injector Assembly, V, w/V3010-15F	Yellow	18"	
	V3010-2W-15G *	2" Injector Assembly, W, w/V3010-15G	Green	21"	
	V3010-2X-15H *	2" Injector Assembly, X, w/V3010-15H	Orange	24"	
3	V3010-2A	2" Injector Assembly A	Stamped A	18"	1
	V3010-2B	2" Injector Assembly B	Stamped B	21"	
	V3010-2C	2" Injector Assembly C	Stamped C	24"	
	V3010-2D	2" Injector Assembly D	Stamped D	30"	
	V3010-2E	2" Injector Assembly E	Stamped E	36"	
	V3010-2F	2" Injector Assembly F	Stamped F	42"	
	V3010-2G	2" Injector Assembly G	Stamped G	48"	

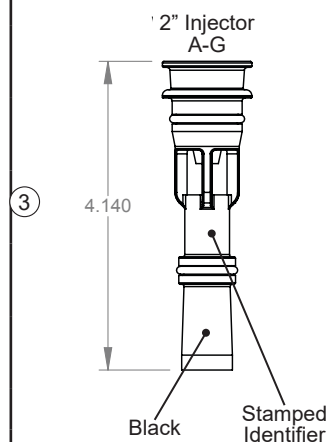

* V3010-2X-15X Injectors contain V3010-15 2" injector adapter with 1.5" injector inside

V3010-2X injectors and the V3010-15ADAPTER contain V3283 O-RING 117 and a V3284 O-RING 114. The V3010-15-ADAPTER can be used with and V3010-15X injector so the 2" valve can be used on smaller tank sizes. The V3010-15X injector contains one V3416 O-RING 012 (lower) and one V3171 O-RING 013 (upper).

Note: Actual injector size may vary depending on the design and application of the system. The injectors are sized for a typical downflow softener using standard mesh synthetic cation exchange media regenerating with sodium chloride. Specification charts and injector graphs are available for specific models. Variances in drain and draw line restrictions will effect injector performance. Consult factory.

Drain Line Flow Controls

See drain line flow control washer section for available flow selections.

PVC Elbow, 0.7-10 GPM

Item	Part#	Description	Qty.
V3158-04		LX2 Drain Fitting, 3/4" Elbow	
1	V3158-03	Drain Elbow, 3/4 NPT	1
2	V3159-01	DLFC Retainer Assembly	1
3	V3163	O-ring, -019	1
4	H4615	Locking Clip	1
5	V3414	LX15 DLFC Adapter	1
5	V3983	LX2 DLFC Adapter	1
6	V3162-xx	See DLFC Section	1

Inline Plastic, 9 - 25 GPM

Item	Part#	Description	Qty.
V3008-04		LX15 Drain Fitting, 1" Straight	
V3008-05		LX2 Drain Fitting, 1" Straight	
1	V3167	Drain Fitting Adapter, 1" NPT	1
2	V3166-01	Drain Fitting Body	1
3	V3151	Nut, QC	1
4	V3150	Split Ring	1
5	V3105	O-ring -215	1
6	V3163	O-ring -019	1
7	H4615	Locking Clip	1
8	V3414	LX15 DLFC Adapter	1
8	V3983	LX2 DLFC Adapter	1
9	V3190-xx	See DLFC Section	1

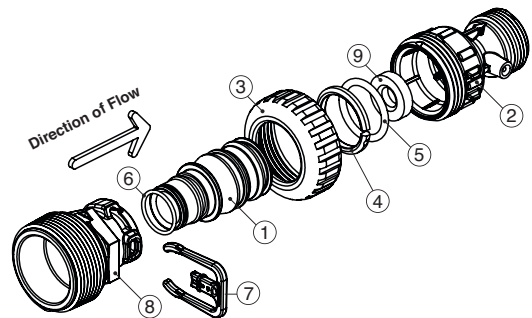
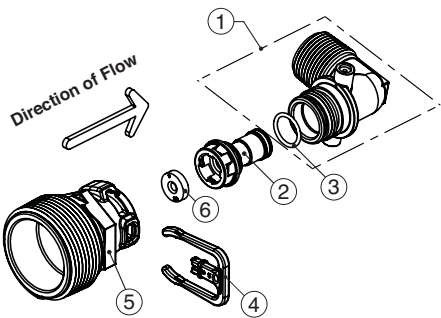

MxF Stainless Steel, 9-85 GPM

Drawing No.	Order No.	Description	Quantity	
			V3079	V3080
1	V3081	LX2 RETAINER DLFC ASY	1	1
2	V3645	LX2 DLFC FLANGE OUTLET FNPT	1	1
3	V3646	LX2 DLFC FLANGE INLET MNPT		1
4	V3388	LX15 DLFC FLANGE INLET MNPT	1	
5	V3652	BOLT HEXHD S/S HCS 5/16-18X3/4	4	4
6	V3441	O-RING 226	1	1
7	V3162-xx	See DLFC Section	0-6	0-6
8	V3190-xx	See DLFC Section	1	1

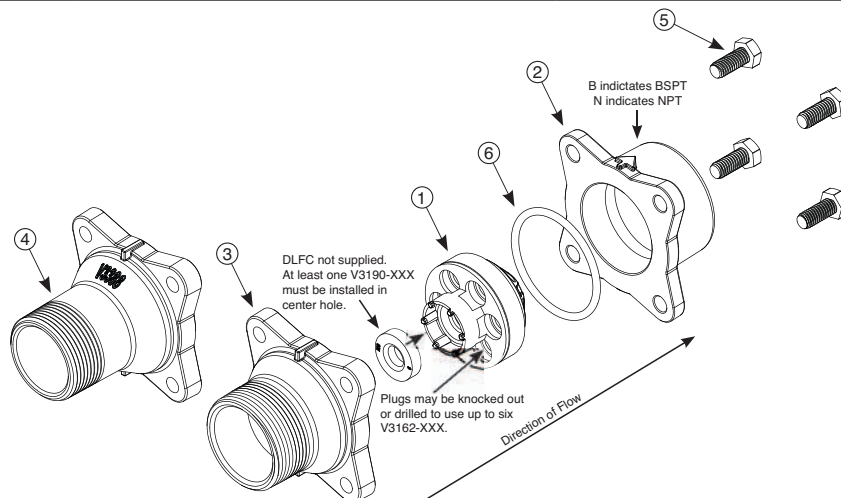

Drain Line Flow Control Washers

Order No.	Description
V3162-007	0.7 GPMDrain line flow control
V3162-010	1.0 GPMDrain line flow control
V3162-013	1.3 GPMDrain line flow control
V3162-017	1.7 GPMDrain line flow control
V3162-022	2.2 GPMDrain line flow control
V3162-027	2.7 GPMDrain line flow control
V3162-032	3.2 GPMDrain line flow control
V3162-042	4.2 GPMDrain line flow control
V3162-053	5.3 GPMDrain line flow control
V3162-065	6.5 GPMDrain line flow control
V3162-075	7.5 GPMDrain line flow control
V3162-090	9.0 GPMDrain line flow control
V3162-100	10.0 GPMDrain line flow control
V3190-090	9.0 GPMDrain line flow control
V3190-100	10.0 GPMDrain line flow control
V3190-110	11.0 GPMDrain line flow control
V3190-130	13.0 GPMDrain line flow control
V3190-150	15.0 GPMDrain line flow control
V3190-170	17.0 GPMDrain line flow control
V3190-200	20.0 GPMDrain line flow control
V3190-250	25.0 GPMDrain line flow control

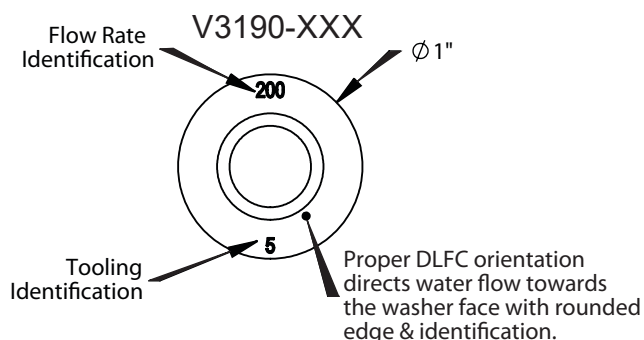
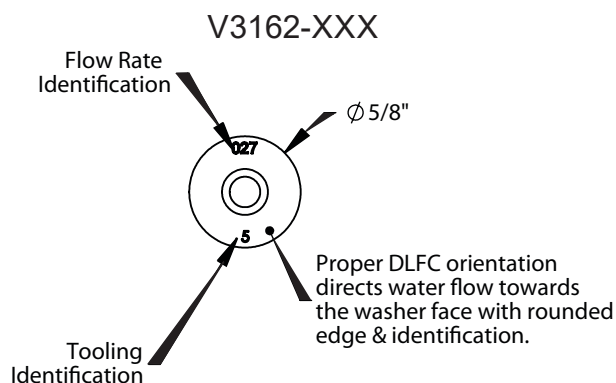

Select control from table for proper backwash, based on particular model specifications. Specifications are available - consult factory.

Servicing Drain Line Flow Control

Disassembly and Inspection

Depending on the flow control installed on the unit, remove the red plastic retaining clip (plastic flow control) or the (4) screws (stainless steel flow control) to expose the flow control and retainer. The flow controls can be removed by flexing the washer with a small screwdriver being careful not to mar the plastic seat. The flow control and retainer may be chemically cleaned using dilute sodium bisulfite or vinegar, do not clean with abrasive methods.

Reassembly

Insert the flow washers back into their respective bores, confirming correct flow control orientation (see diagram in the exploded view section). Place back into the housing and reassemble the housing/fitting. Do not use Vasoline, oils or other unacceptable lubricants on o-rings. A silicone lubricant may be used on the o-ring of the elbow or the retainer, but not on the flow control or its seat.

Meter Assembly for 1.5" and 2" Valves

Note: Be sure the proper meter size is programmed in the software.

Standard meter cable used for spacing up to 3" between valve body and meter body, longer distance requires longer cable # V3221.

Service or replace the turbine by:

1. Turn the bypass for the system on and relieve the pressure on the system before removing the meter.
2. Press downward on the remote meter assembly to relieve tension on the retaining clip V3632. Remove the clip and take the meter assembly out of the housing.
3. Remove the bend from the two exposed tips of the retaining clip V3501 and remove clip.
4. Service or replace the V3118-03 Turbine Assembly and place it back on the turbine shaft.
5. Insert the V3501 Turbine Clip and re-bend the exposed ends of the clip. The V3118-03 turbine has a groove to line up with the V3501 Turbine Clip.
6. Insert meter assembly back into the meter housing.
7. Re-install the meter retaining clip V3632 as shown below
8. Open the bypass for the system slowly to bring back into service and check to be sure you have no water leaks.

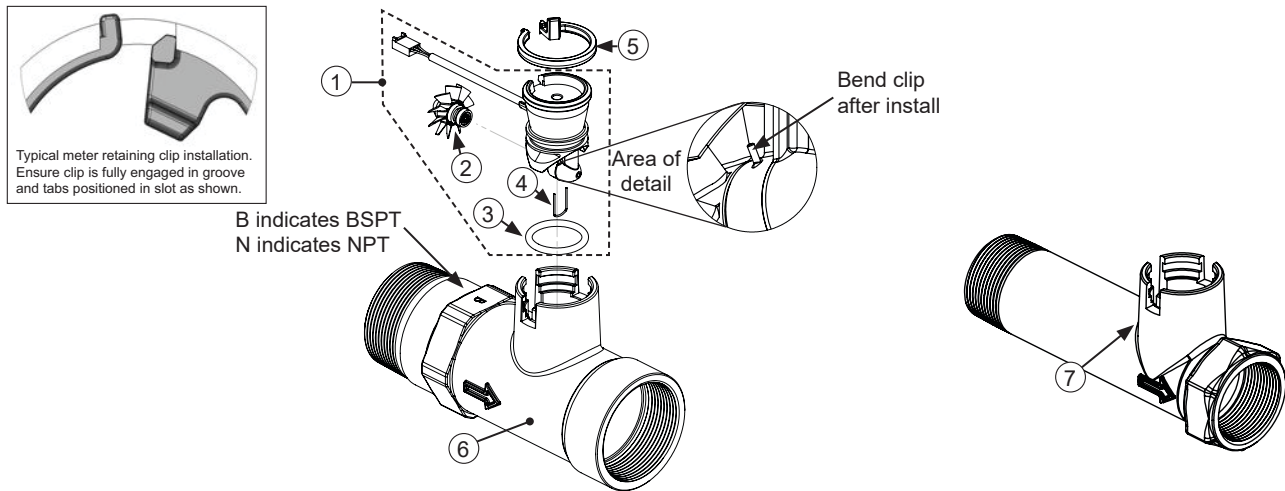

V3040	1.5" NPT Meter, 28" Cable
V3040-15	1.5" NPT Meter, 15' Cable
V3094	2" NPT Meter, 28" Cable
V3094-15	2" NPT Meter, 15' Cable

Drawing No.	Order No.	Description	Quantity
1	V3003-02	Commercial meter assembly, 28" Cable	1
	V3221	Commercial meter assembly, 15' Cable	
2	V3118-03	Commercial meter turbine assembly	1
3	V3105	O-ring, -215	1
4	V3501	Turbine clip	1
5	V3632*	Meter Retaining Clip	1
6	V3754-01	2" Meter Housing NPT	1
7	V3401-04	1.5" Meter Housing NPT	1
Not Shown	V3437	1.5" Flow Straightener	1
	V3488	2" Flow Straightener	

WHEN INSTALLING THE METER, MAKE SURE THE ARROW ON THE METER BODY IS GOING THE SAME DIRECTION AS THE WATER FLOW. THIS WATER METER SHOULD NOT BE USED AS THE PRIMARY MONITORING DEVICE FOR CRITICAL OR HEALTH EFFECT APPLICATIONS.

OPERATING PRESSURES: 20 PSI MINIMUM / 125 PSI MAXIMUM • OPERATING TEMPERATURES: 40°F MINIMUM / 110°F MAXIMUM

*The meter can be installed in either horizontal or vertical applications.

Service Instructions

1) Drive Assembly

Disassembly and Inspection:

Remove the valve cover to access the drive assembly.

The drive bracket must be removed to access the drive cap assembly and the piston or the drive gear cover. It is not necessary to remove the PC board from the drive bracket to remove the drive bracket. Disconnect the power source plug (4 pin, black cable) from the PC board prior to disconnecting any other plugs from the PC board. Disconnect any MAV/AUX drive motors (2 pin, black cable) from the PC board. Disconnect the water meter plug (3 pin, gray cable), located on the far right side of the PC board. The water meter plug (3 pin, gray wire) connects to the three-pin jack on the far right-hand side of the PC board. Unweave the wires from the side holders. Two tabs on the top of the drive back plate hold the drive bracket in place. Simultaneously lift the two tabs and gently ease the top of the drive bracket towards your body. The lower edge of the drive bracket has two notches that rest on the drive back plate. Lift up and outward on the drive bracket to disengage the notches.

To inspect the drive reduction gears, the drive gear cover needs to be removed. The drive gear cover is held in place on the drive bracket by three clips. The largest of the three clips is always orientated to the bottom of the drive bracket. With the PC board facing up, push in and down on the largest clip on the drive gear cover. Handle the cover and gears carefully so that the gears do not fall off of the pegs in the cover. Replace broken or damaged drive gears. Do not lubricate any of the gears. Avoid getting any foreign matter on the reflective coating because dirt or oils may interfere with pulse counting.

The drive bracket does not need to be removed from the drive plate if the motor needs to be removed. To remove the motor, disconnect the power and motor plugs from the jacks on the PC board. Move the spring clip loop to the right and hold. Rotate the motor at least a $\frac{1}{4}$ turn in either direction before gently pulling on the wire connectors to remove the motor. Pulling directly on the wires without rotating the motor may break the wires off the motor. Visually inspect the motor for free spinning and remaining brush life (visible through slots on the side of the motor). Check the pinion gear for endplay. If the pinion gear is pushed tight against the motor housing, eliminating endplay, slide it away from the housing so the end of the shaft is flush with the end of the gear.

The PC board can be removed separately from the drive bracket but it is not recommended. Do not attempt to remove the display panel from the PC board. Handle the board by the edges. To remove the PC board from the drive bracket, unplug the power, water meter and motor plugs from the PC board. Lift the middle latch along the top of the drive bracket while pulling outward on the top of the PC board. The drive bracket has two plastic pins that fit into the holes on the lower edge of the PC board. Once the PC board is tilted about 45° from the drive bracket it can be lifted off of these pins. To reinstall the PC board, position the lower edge of the PC board so that the holes in the PC board line up with the plastic pins. Push the top of the PC board towards the valve until it snaps under the middle latch, weave the power and the water meter wires into the holders and reconnect the motor, water meter and power plugs.

Reassembly:

If the drive gear cover was removed, reinstall it with the large clip orientated towards the bottom. If all three clips are outside of the gear shroud on the drive bracket the drive gear cover slips easily into place

To reinstall the drive bracket, seat the bottom of the drive bracket so the notches are engaged at the bottom of the drive back plate. Push the top of the drive bracket towards the two latches. The drive bracket may have to be lifted slightly to let the threaded piston rod pass through the hole in the drive bracket. Maintain a slight engaging force on top of the drive bracket while deflecting the bracket slightly to the left by pressing on the side of the upper right corner. This helps the drive gears mesh with the drive cap assembly. The drive bracket is properly seated when it snaps under the latches on the drive back plate. If resistance is felt before latching, then notches are not fully engaged, the piston rod is not in hole, the wires are jammed between the drive bracket and drive back plate, or the gear is not engaging the drive cap assembly.

Replace the motor if necessary. Do not lubricate the motor or the gears. To reinstall the motor, move the spring clip loop to the right and hold. Gently turn the motor while inserting so that the gear on the motor meshes with the gears under the drive gear cover. Release the spring clip loop and continue to rotate the motor until the motor housing engages the small plastic bulge inside the drive bracket motor retainer. Reconnect the motor plug to the two-pronged jack on the lower left hand side of the PC board. If the motor will not easily engage with the drive gear when reinstalling, lift and slightly rotate the motor before reinserting. Reconnect the power plug.

Replace the valve cover. After completing any valve maintenance, press and hold NEXT and REGEN buttons for 3 seconds or unplug power source jack (black wire) and plug back in. This resets the electronics and establishes the service piston position. The display should flash all wording, then flash the software version and then reset the valve to the service position.

2) Drive Cap Assembly

Disassembly 1.5" Valves:

Turn off supply water and relieve system pressure. The drive assembly must be removed to access the drive cap assembly. The drive cap assembly must be removed to access the piston(s). The drive cap assembly is threaded into the control valve body and seals with an o-ring. To remove the drive cap assembly use the special plastic wrench (V3193-02 Figure 1) or insert a 1/4" to 1/2" flat bladed screwdriver into one of the slots around the top 2" of the drive cap assembly so it engages the notches molded into the drive backplate around the top 2" of the piston cavity. See Figure 2. The notches are visible through the holes. Lever the screwdriver so the drive cap assembly turns counter clockwise. Once loosened, unscrew the drive cap assembly by hand and pull straight out.

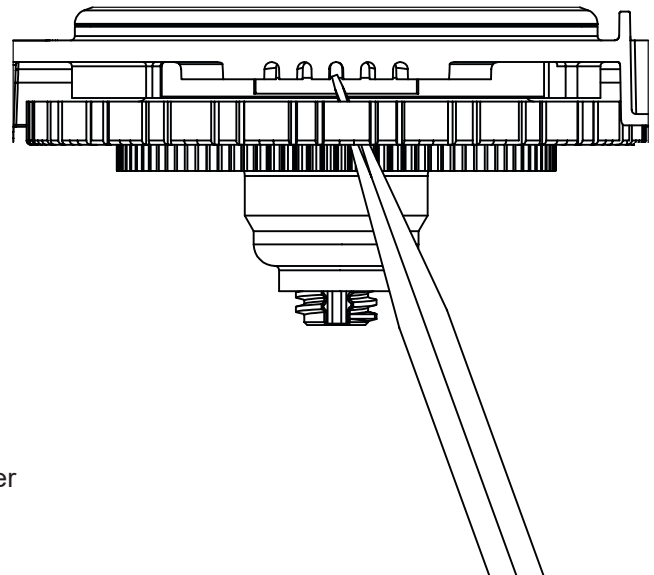
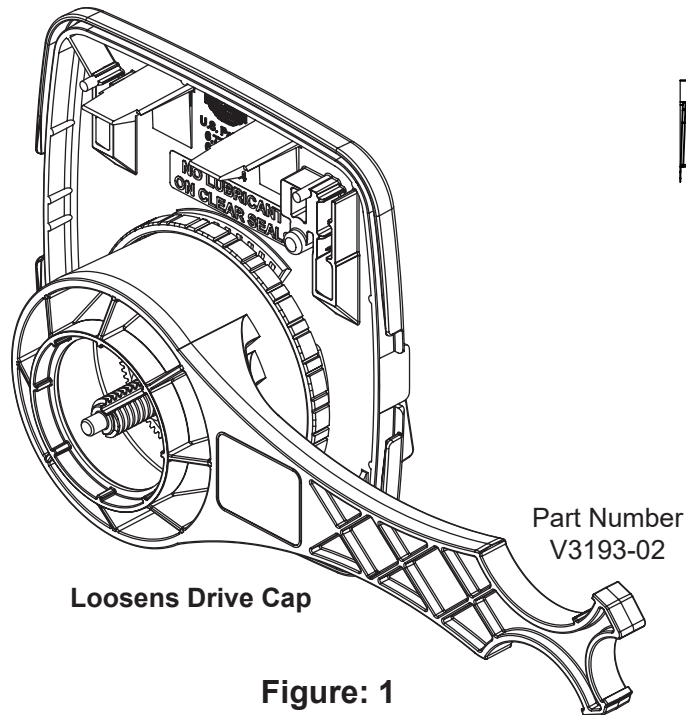

Figure: 2

Disassembly, 2" Valves:

After removing the bracket assembly the drive back plate can be removed by squeezing the 2 locking tabs (located at 3 and 9 o'clock around the white gear) and rotating the back plate counter clockwise. The four 1/4-20 screws can then be removed and the drive cap pulled straight back out of the valve. Turning the main gear counter clockwise drives the piston in and may aid in pushing out the cap.

Inspection:

The drive cap assembly contains the drive cap, the main drive gear, drive cap spline, piston rod and various other parts that should not be disassembled in the field. Visually inspect the drive cap for damage and free operation of the gear and threaded rod. The only replaceable part on the drive cap assembly is the o-ring.

3) Main Piston and Regenerant Piston

Disassembly and Inspection:

Attached to the drive cap assembly is the main piston and depending on the configuration, a regenerant piston. The regenerant piston (the small diameter one behind the main piston) is removed from the main piston by unsnapping it from its disassembly latch. To remove the main down flow piston fully extend the piston rod and then unsnap the main piston from its latch by pressing on the side with the number. Chemically clean the piston in dilute sodium bisulfite or vinegar, or replace them. The main piston is teflon coated. If the teflon coating is abraded, replace the main piston.

Reassembly:

Reattach the main piston to the drive cap assembly. Reattach the regenerant piston (if needed) to the main piston. Reinsert the drive cap assembly and piston into the spacer stack assembly and hand tighten the drive cap assembly. Continue to tighten the drive cap assembly until the backside of the drive cap bottoms out flush with the casting or the black o-ring on the spacer stack assembly is no longer visible through the drain port. Excessive force can break the notches molded into the drive back plate. Make certain that the main drive gear still turns freely. The exact position of the piston is not important as long as the main drive gear turns freely.

Reattach the drive assembly to the control valve and connect all plugs. After completing any valve maintenance, press and hold NEXT and REGEN buttons for 3 seconds or unplug power source jack (4 pin, black cable) and plug back in. This resets the electronics and establishes the service piston position. The display should flash all wording, then flash the software version and then reset the valve to the service position.

4) Spacer Stack Assembly

Disassembly and Inspection:

To access the spacer stack assembly remove the drive assembly, drive cap assembly and piston. The spacer stack assembly can then be pulled straight out. Inspect the black o-rings and inner seals for wear or damage, replace the entire stack if necessary. Do not disassemble the stack.

The spacer stack assembly may be chemically cleaned (dilute sodium bisulfite or vinegar) or wiped with a soft cloth.

Reassembly:

The spacer stack assembly can be pushed into the control valve body bore by hand. The assembly is properly seated when at least four threads are exposed (approximately 5/8"). Do not force the spacer stack assembly in. The control valve body bore interior can be lubricated with silicone to allow for easy insertion of the entire stack.

Reattach the drive cap assembly and piston(s) and the drive assembly.

After completing any valve maintenance, press and hold NEXT and REGEN buttons for 3 seconds or unplug the power source jack (4 pin, black cable) and plug back in. This resets the electronics and establishes the service piston position. The display should flash all wording, then flash the software version and then reset the valve to service position

5) Injector Cap, Screen, Injector Plug and Injector

Disassembly and Inspection:

LXCV15 Body and LXCV2/LXCV2QC

The injector can be accessed at the back of the valve by removing the threaded injector cap. The cap is removed by using the V3193-02 service wrench (figure 1).

Once the cap is removed:

- LXCV15 valve can use the bottom threaded edge of the injector cap at an angle to pry out the injector
- LXCV2/LXCV2QC valves can use the open end of the BPV3193-02 service wrench at an angle to pry out the injector.

An injector consists of a throat and nozzle. It can be chemically cleaned with vinegar or dilute sodium bisulfate. The holes can be blown out by air. Sharp objects, which can score the plastic, should not be used to clean the injector. Scoring the injector or increasing the diameter of the injector hole could change the operating parameters of the injector.

If the LXCV15 valve does not use a regenerant the injector plug should not need to be cleaned, just verify that it has both o-rings on the plug and that it is fully seated.

Reassembly:

Press injector into its bore hole and press until seated all the way down. Replace the injector cap.

6) Refill Flow Control Assembly or Refill Port Plug

Disassembly and Inspection:

To clean or replace the refill flow control, remove the nut (2" valves) or pull out the locking clip (1.5" valves) and then pull the fitting straight out. Remove the flow control retainer. The flow control can be removed by prying upward through the side slots of the retainer with a small blade flat screwdriver, being careful not to mar the plastic seat.

Chemically clean the flow control or the flow control retainer using dilute sodium bisulfite or vinegar. **Do not clean with abrasive methods.** If necessary, replace the flow control, o-ring on the flow control retainer, or the o-ring on the fitting.

Reassembly:

Insert the flow control into its seat, confirming correct flow control orientation. Reseat the flow control retainer and reassemble the fitting (see diagram in the exploded view section).

Do not use Vaseline, oils, or other unacceptable lubricants on o-rings. A silicon lubricant may be used on the o-ring on the elbow or the retainer, but not on the flow control or its seat.

Refill port plugs should not need to be service. O-rings may be replaced if necessary.

7) Regenerant Body

Disassembly and Inspection:

Turn off supply water & relieve system pressure.

The regenerant body would typically only be removed for servicing of the injector screen (not applicable to 2" valves). Removing the injector cap can allow much of the contained water to drain before removing the body. Remove the (4) ¼-20 screws, the body can then be pulled straight back off the main body taking care to not lose the o-ring between the regenerant & main body. The injector screen is installed inside the plastic body behind the injector feed tube. The injector screen can be pushed out from the half round hole feature behind the injector cap.

Reassembly:

Insert the injector feed and draw tubes into the main body, bottoming them out in their bores. Install the injector screen in the 1.5 regenerant body, the small hole in the end of the screen will nest around a feature in the plastic body allowing the large end to be flush with a step in the tube bore. Confirm the placement of the o-ring on the flange of the plastic body then press the regenerant body straight onto the main body, assuring the o-rings engages the bore in the main body. Install & tighten the (4) ¼-20 screws. The lower injector o-ring engages the ID of the injector tube which may push the injector out of position when reinstalling the regenerant body. Verify the injector is seated all the way down into its bore, then reinstall the injector cap.

TROUBLESHOOTING

Problem	Possible Cause	Solution
1. No Display on PC Board	a. No power at electric outlet	a. Repair outlet or use working outlet
	b. Control valve Power Adapter not plugged into outlet or power cord end not connected to PC board connection	b. Plug Power Adapter into outlet or connect power cord end to PC Board connection
	c. Improper power supply	c. Verify proper voltage is being delivered to PC Board
	d. Defective Power Adapter	d. Replace Power Adapter
	e. Defective PC Board	e. Replace PC Board
2. PC Board does not display correct time of day	a. Power Adapter plugged into electric outlet controlled by light switch	a. Use uninterrupted outlet
	b. Tripped breaker switch and/or tripped GFI	b. Reset breaker switch and/ or GFI switch
	c. Power outage	c. Reset time of day. If PC Board has battery back up present the battery may be depleted. See Front Cover and Drive Assembly drawing for instructions.
	d. Defective PC Board	d. Replace PC Board
3. Display does not indicate that water is flowing. Refer to user instructions for how the display indicates water is flowing	a. Bypass valve in bypass position	a. Turn bypass handles to place bypass in service position
	b. Meter is not connected to meter connection on PC Board	b. Connect meter to three pin connection labeled METER on PC Board
	c. Restricted/ stalled meter turbine	c. Remove meter and check for rotation or foreign material
	d. Meter wire not installed securely into three pin connector	d. Verify meter cable wires are installed securely into three pin connector labeled METER
	e. Defective meter	e. Replace meter
	f. Defective PC Board	f. Replace PC Board
4. Control valve regenerates at wrong time of day	a. Power outage	a. Reset time of day. If PC Board has battery back up present the battery may be depleted. See Front Cover and Drive Assembly drawing for instructions.
	b. Time of day not set correctly	b. Reset to correct time of day
	c. Time of regeneration set incorrectly	c. Reset regeneration time
	d. Control valve set at immediate regeneration	d. Check programming setting and reset to DELAYED (for a delayed regen time)
	e. Control valve set at (delayed + immediate)	e. Check programming setting and reset to DELAYED (for a delayed regen time)
5. Time of day flashes on and off	a. Power outage	a. Reset time of day. If PC Board has battery back up present the battery may be depleted. See Front Cover and Drive Assembly drawing for instructions.
6. Control valve does not regenerate automatically when the REGEN button is depressed	a. Broken drive gear or drive cap assembly	a. Replace drive gear or drive cap assembly
	b. Broken Piston Rod	b. Replace piston rod
	c. Defective PC Board	c. Replace PC Board
7. Control valve does not regenerate automatically but does when the REGEN button is depressed and held.	a. Bypass valve in bypass position	a. Turn bypass handles to place bypass in service position
	b. Meter is not connected to meter connection on PC Board	b. Connect meter to three pin connection labeled METER on PC Board
	c. Restricted/ stalled meter turbine	c. Remove meter and check for rotation or foreign material
	d. Incorrect programming	d. Check for programming error
	e. Meter wire not installed securely into three pin connector	e. Verify meter cable wires are installed securely into three pin connector labeled METER
	f. Defective meter	f. Replace meter
	g. Defective PC Board	g. Replace PC Board

Problem	Possible Cause	Solution
8. Hard or untreated water is being delivered	a. Bypass valve is open or faulty	a. Fully close bypass valve or replace
	b. Media is exhausted due to high water usage	b. Check program settings or diagnostics for abnormal water usage
	c. Meter not registering	c. Remove meter and check for rotation or foreign material
	d. Water quality fluctuation	d. Test water and adjust program values accordingly
	e. No regenerant or low level of regenerant in regenerant tank	e. Add proper regenerant to tank
	f. Control fails to draw in regenerant	f. Refer to Trouble Shooting Guide number 12
	g. Insufficient regenerant level in regenerant tank	g. Check refill setting in programming. Check refill flow control for restrictions or debris and clean or replace
	h. Damaged seal/stack assembly	h. Replace seal/stack assembly
	i. Control valve body type and piston type mix matched	i. Verify proper control valve body type and piston type match
	j. Fouled media bed	j. Replace media bed
9. Control valve uses too much regenerant	a. Improper refill setting	a. Check refill setting
	b. Improper program settings	b. Check program setting to make sure they are specific to the water quality and application needs
	c. Control valve regenerates frequently	c. Check for leaking fixtures that may be exhausting capacity or system is undersized
10. Residual regenerant being delivered to service	a. Low incoming water pressure	a. Check pressure – must remain at minimum of 20 psi. If possible, increase pump switch cut-in to 25 psi.
	b. Incorrect injector size	b. Replace injector with correct size for the application
	c. Restricted drain line	c. Check drain line for restrictions or debris and clean
11. Excessive water in regenerant tank	a. Improper program settings	a. Check refill setting
	b. Plugged injector	b. Remove injector and clean or replace
	c. Drive cap assembly not tightened in properly	c. Re-tighten the drive cap assembly
	d. Damaged seal/ stack assembly	d. Replace seal/ stack
	e. Restricted or kinked drain line	e. Check drain line for restrictions or debris and or un-kink drain line
	f. Plugged backwash flow controller	f. Remove backwash flow controller and clean or replace
	g. Missing refill flow controller	g. Replace refill flow controller
12. Control valve fails to draw in regenerant	a. Injector is plugged	a. Remove injector and clean or replace
	b. Faulty regenerant piston	b. Replace regenerant piston
	c. Regenerant line connection leak	c. Inspect regenerant line for air leak
	d. Drain line restriction or debris cause excess back pressure	d. Inspect drain line and clean to correct restriction
	e. Drain line too long or too high	e. Shorten length and or height
	f. Low incoming water pressure	f. Check pressure – must remain at minimum of 20 psi. If possible, increase pump switch cut-in to 25 psi.
13. Water running to drain	a. Power outage during regeneration	a. Upon power being restored control will finish the remaining regeneration time. Reset time of day
	b. Damaged seal/ stack assembly	b. Replace seal/ stack assembly
	c. Piston assembly failure	c. Replace piston assembly
	d. Drive cap assembly not tightened in properly	d. Re-tighten the drive cap assembly

Problem	Possible Cause	Solution
14. Error – 101 = Control unable to sense motor movement	a. Motor not inserted full to engage pinion, motor wires broken or disconnected	a. Disconnect power, make sure motor is fully engaged, check for broken wires, make sure two pin connector on motor is connected to the two pin connection on the PC Board labeled MOTOR. Press NEXT and REGEN buttons for 3 seconds to resynchronize software with piston position or disconnect power supply from PC Board for 5 seconds and then reconnect.
	b. PC Board not properly snapped into drive bracket	b. Properly snap PC Board into drive bracket and then Press NEXT and REGEN buttons for 3 seconds to resynchronize software with piston position or disconnect power supply from PC Board for 5 seconds and then reconnect.
	c. Missing reduction gears	c. Replace missing gears
15. Error – 102 = Control valve motor ran too short and was unable to find the next cycle position and stalled	a. Foreign material is lodged in control valve	a. Open up control valve and pull out piston assembly and seal/ stack assembly for inspection. Press NEXT and REGEN buttons for 3 seconds to resynchronize software with piston position or disconnect power supply from PC Board for 5 seconds and then reconnect.
	b. Mechanical binding	b. Check piston and seal/ stack assembly, check reduction gears, check drive bracket and main drive gear interface. Press NEXT and REGEN buttons for 3 seconds to resynchronize software with piston position or disconnect power supply from PC Board for 5 seconds and then reconnect.
	c. Main drive gear too tight	c. Loosen main drive gear. Press NEXT and REGEN buttons for 3 seconds to resynchronize software with piston position or disconnect power supply from PC Board for 5 seconds and then reconnect.
	d. Improper voltage being delivered to PC Board	d. Verify that proper voltage is being supplied. Press NEXT and REGEN buttons for 3 seconds to resynchronize software with piston position or disconnect power supply from PC Board for 5 seconds and then reconnect.
16. Error – 103 = Control valve motor ran too long and was unable to find the next cycle position	a. Motor failure during a regeneration	a. Check motor connections then Press NEXT and REGEN buttons for 3 seconds to resynchronize software with piston position or disconnect power supply from PC Board for 5 seconds and then reconnect.
	b. Foreign matter built up on piston and stack assemblies creating friction and drag enough to time out motor	b. Replace piston and stack assemblies. Press NEXT and REGEN buttons for 3 seconds to resynchronize software with piston position or disconnect power supply from PC Board for 5 seconds and then reconnect.
	c. Drive bracket not snapped in properly and out enough that reduction gears and drive gear do not interface	c. Snap drive bracket in properly then Press NEXT and REGEN buttons for 3 seconds to resynchronize software with piston position or disconnect power supply from PC Board for 5 seconds and then reconnect.

Problem	Possible Cause	Solution
17. Error – 104 = Control valve motor ran too long and timed out trying to reach home position	a. Drive bracket not snapped in properly and out enough that reduction gears and drive gear do not interface	a. Snap drive bracket in properly then Press NEXT and REGEN buttons for 3 seconds to resynchronize software with piston position or disconnect power supply from PC Board for 5 seconds and then reconnect.
18. Error -106 = MAV/ SEPS/ NHBP/ AUX MAV valve motor ran too long and unable to find the proper park position Motorized Alternating Valve = MAV Separate Source = SEPS No Hard Water Bypass = NHBP Auxiliary MAV = AUX MAV	a. Control valve programmed for ALT A or B, nHbP, SEPS, or AUX MAV with out having a MAV or NHBP valve attached to operate that function	a. Press NEXT and REGEN buttons for 3 seconds to resynchronize software with piston position or disconnect power supply from PC Board for 5 seconds and then reconnect. Then re-program valve to proper setting
	b. MAV/ NHBP motor wire not connected to PC Board	b. Connect MAV/ NHBP motor to PC Board two pin connection labeled MAV MTR. Press NEXT and REGEN buttons for 3 seconds to resynchronize software with piston position or disconnect power supply from PC Board for 5 seconds and then reconnect.
	c. MAV/ NHBP motor not fully engaged with reduction gears	c. Properly insert motor into casing, do not force into casing. Press NEXT and REGEN buttons for 3 seconds to resynchronize software with piston position or disconnect power supply from PC Board for 5 seconds and then reconnect.
	d. Foreign matter built up on piston and stack assemblies creating friction and drag enough to time out motor	d. Replace piston and stack assemblies. Press NEXT and REGEN buttons for 3 seconds to resynchronize software with piston position or disconnect power supply from PC Board for 5 seconds and then reconnect.
19. Error – 107 = MAV/ SEPS/ NHBP/ AUX MAV valve motor ran too short (stalled) while looking for proper park position Motorized Alternating Valve = MAV Separate Source = SEPS No Hard Water Bypass = NHBP Auxiliary MAV = AUX MAV	a. Foreign material is lodged in MAV/ NHBP valve	a. Open up MAV/ NHBP valve and check piston and seal/ stack assembly for foreign material. Press NEXT and REGEN buttons for 3 seconds to resynchronize software with piston position or disconnect power supply from PC Board for 5 seconds and then reconnect.
	b. Mechanical binding	b. Check piston and seal/ stack assembly, check reduction gears, drive gear interface, and check MAV/ NHBP black drive pinion on motor for being jammed into motor body. Press NEXT and REGEN buttons for 3 seconds to resynchronize software with piston position or disconnect power supply from PC Board for 5 seconds and then reconnect.

NOTES



A DIVISION OF C-B TOOL CO.
1340 MANHEIM PIKE • LANCASTER PA 17601-3196 • TEL:717-397-3521 • FAX: 717-392-0266
www.lancasterwatergroup.com • E-mail: info@lancasterwatergroup.com