

# MASCONTROL™

by TREVITECH

DOMESTIC PUMP CONTROL

## OWNER'S MANUAL

Mod. MCA ( 1" connections ) - Mod. MCB ( 1 ¼" connections )  
115 / 230 VAC DUAL VOLTAGE UNIT

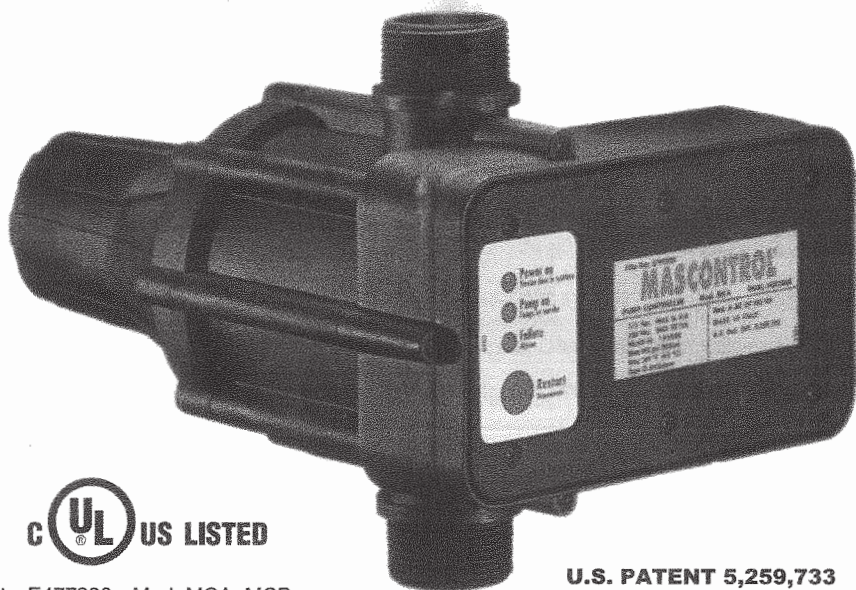

File No: E477339 Mod. MCA, MCB

U.S. PATENT 5,259,733

### FEATURES & BENEFITS

MASCONTROL can be installed on surface and submersible pumps for residential, domestic irrigation and booster systems.

- Maintains constant pressure and flow.
- Eliminates pump pressure switch.
- Built-in pressure and flow switch.
- Built-in check valve.
- Built-in dry-run protection.
- Assists in absorbing water hammer.
- Increases pump life.
- Dual voltage 115 / 230 VAC.
- No adjustment or maintenance required.
- Simple installation saves space and time.
- Can be used with or without pressure tank.
- All stainless steel construction.

# TABLE OF CONTENTS

	Page
Warning and Precautions .....	3
Technical specifications .....	4
Operation .....	4
Troubleshooting .....	4
Maintenance and spare parts .....	4
Hydraulic connection to the system .....	5
Conduit connections .....	5
Pressure .....	6
Pressure loss .....	7
Typical MASCONTROL installation on surface and submersible pumps .....	8
MASCONTROL installation guidelines and warnings .....	9
MASCONTROL installation with pressure tank option .....	9
Electrical connections .....	10
Installation wiring diagram - 115 VAC 2-wire pumps up to 16 FLA .....	10
Installation wiring diagram - 230 VAC single phase 2-wire pumps up to 20 FLA .....	11
Installation wiring diagram - 230 VAC single phase 3-wire pumps up to 20 FLA .....	11
When to use contactors .....	12
Installation wiring diagram - 115 VAC 2-wire pumps up to 16 FLA .....	12
Installation wiring diagram - 230 VAC single phase 2-wire pumps exceeding 20 FLA .....	12
Installation wiring diagram - 208 VAC or 230 VAC three phase 3-wire pumps .....	13
Installation wiring diagram - 460 VAC .....	13
Installation wiring diagram - 230 VAC single phase 3-wire pumps exceeding 20 FLA .....	14
Overall dimensions .....	14
Electronic box replacement .....	15
Warranty .....	16
Patent infringement .....	16



## READ THESE INSTRUCTIONS CAREFULLY BEFORE INSTALLATION

INSTALLER - PLEASE LEAVE THIS MANUAL WITH THE UNIT OR GIVE TO END USER.

**FAILURE TO READ AND CONSIDER SAFETY INSTRUCTIONS IN THIS MANUAL OR ON MASCONTROL MAY RESULT IN PERSONAL INJURY OR SERIOUS DAMAGE TO PIPING OR FIXTURES !**



This is the safety alert. When you see this symbol in this manual, look for one of the following signal words and be alert to the potential for personal injury.



**DANGER**

Warns about hazards that **will** cause serious personal injury, death or major property damaged if ignored.



**WARNING**

Warns about hazards that **can** cause serious personal injury, death or major property damaged if ignored.



**DANGER**

**Hazardous pressure.**



**WARNING**

Under certain conditions, submersible pumps can develop extremely high pressure. Install a pressure reducing valve to limit pressure to safe levels for application. Be sure well is equipped with a pressure relief valve.



Do not allow pump, MASCONTROL, piping, or any other system component containing water to freeze. Freezing may damage system, leading to injury or flooding. Allowing MASCONTROL or system components to freeze will void warranty.



**DANGER**

**Hazardous voltage.**



**WARNING**

Can shock, burn or cause death.



Install ground and wire MASCONTROL according to local code and National Electrical Code requirements.



Depressurize the system and disconnect power supply before installing or servicing MASCONTROL.



Make sure line voltage and frequency of power supply match motor nameplate voltage and frequency and MASCONTROL voltage and frequency.

Install MASCONTROL according to all plumbing, pump and well code requirements.

Pipe joint compound can cause cracking in plastic. Use only Teflon tape when sealing joints in plastic pipe or connecting pipe to thermoplastic pumps and MASCONTROL.

For threaded conduit opening - To be used with UL Listed or Recognized, liquid-tight non-metallic (plastic) conduit fittings.

**The manufacturer is not responsible or liable for damage due to improper installation or use.**

## TECHNICAL SPECIFICATIONS

- Single phase power-supply voltage	115 / 230 VAC
- Voltage variation tolerance	+/- 10 %
- Frequency	50 / 60 Hz
- Full load amp rating 115 VAC	16 FLA
- Full load amp rating 230 VAC	20 FLA
- Electronic box	NEMA 12 enclosure
- Threaded conduit connections	½" FPT
- Max working pressure	145 psi
- Max working temperature	149 °F (65°C)
- Inlet / Outlet connections model MCA	1" MPT
- Inlet / Outlet connections model MCB	1 ¼" MPT

## OPERATION

- Power on**
  - Displays when power is connected to MASCONTROL unit.
  - In the event of a temporary power outage, MASCONTROL resets automatically when power is restored.
- Pump on**
  - Displays when pump is running.
- Failure**
  - Displays when there is a problem with the system.
- Restart**
  - Press and hold to reset for 3-5 seconds ( with a tap opened ). Green "Power on" light and yellow "Pump on" should display. This indicates system is operating properly.
  - If red "Failure" light comes back on, refer to Troubleshooting Guide.

## TROUBLESHOOTING ( Excluding by-pass installation )

Type of problem	Caused by system
Pump does not start	Check wiring connections. Check inlet piping, see page 8.
Pump turns on and off (short-cycles)	Leakage lower than minimum flow.
Pump does not stop	Water flow above minimum flow.
No water flow	Suction or inlet problems.
Low or no pressure at highest point of system	Refer to Pressure Section page 5.
Excessive pressure system	Pump oversized for system. Install pressure reducing valve.
Pump runs +/- 8 seconds after flow to system stops	OK - Pump is repressuring system.

## MAINTENANCE AND SPARE PARTS

Device requires no maintenance.  
The electronic box may be supplied as spare parts.

## HYDRAULIC CONNECTION TO THE SYSTEM

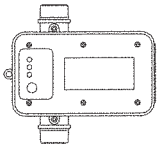

OK

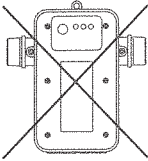

NO

Always install MASCONTROL with flow arrows in the vertical position. Electronic box should be level.

**Do not install any tee or tap between pump and MASCONTROL unit.**

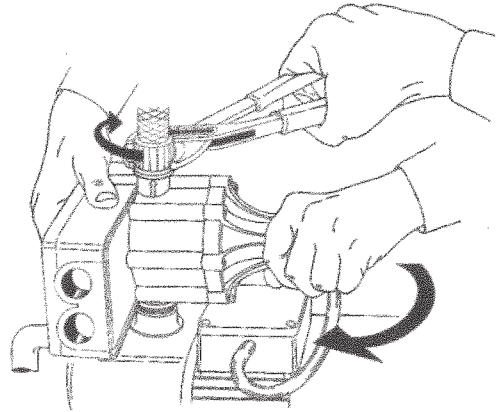
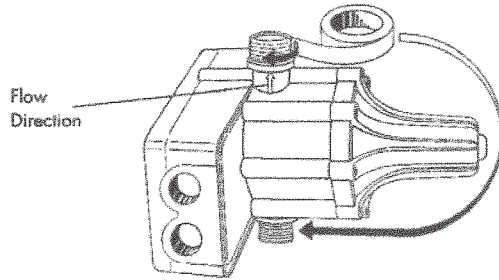

Prepare all threads with Teflon tape only.

**Do not over tighten water connections, especially when installing with metal couplings. Damage to MASCONTROL may result.**

## CONDUIT CONNECTIONS

Open the electronic box cover by removing the six screws from the cover.

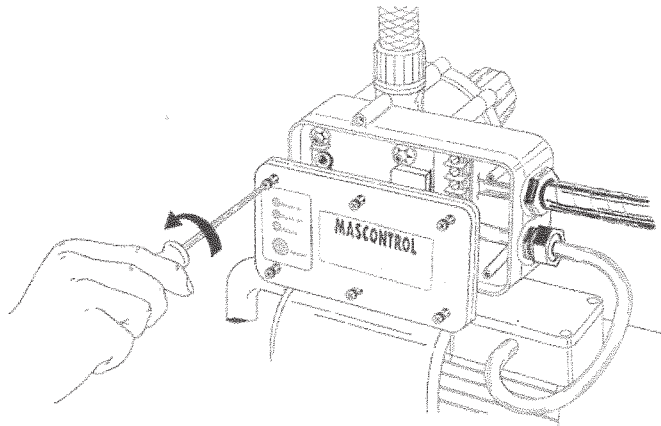

Line voltage and pump wires to the MASCONTROL should be supplied through "liquid-tight" nonmetallic conduit fittings rated "NEMA 12" or "UL type 12" to achieve NEMA Type 12 enclosure rating.

**Failure to install unit without use of liquid tight conduit, voids warranty!**

## PRESSURE

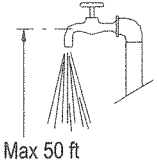
**A**

Max 50 ft

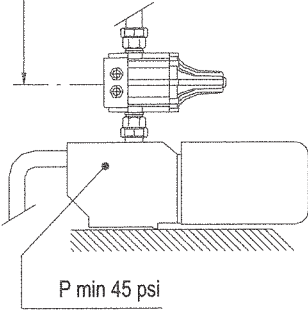

P min 45 psi

**22 psi MODEL****B**

Max 70 ft

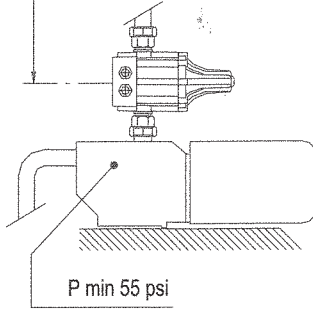

P min 55 psi

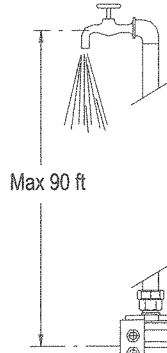
**32 psi MODEL****C**

Max 90 ft

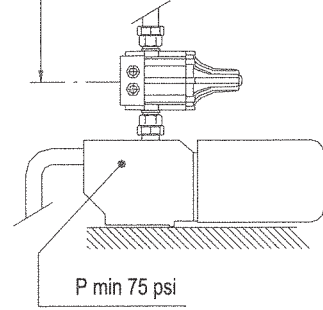

P min 75 psi

**42 psi MODEL**

Both MASCONTROL models MCA and MCB can be provided with three different factory preset cut-in pressures. Use the appropriate guidelines below for the specific model.

### **A - MASCONTROL preset cut-in pressure 22 psi model:**

- Max pressure generated by the pump at zero flow (Pump Shut Off Pressure) must be at least 45 psi.
- The column of water between MASCONTROL and the highest tap must not exceed 50 feet.
- MASCONTROL unit operates from min 22 psi to the max pressure generated by the pump.

### **B - MASCONTROL preset cut-in pressure 32 psi model:**

- Max pressure generated by the pump at zero flow (Pump Shut Off Pressure) must be at least 55 psi.
- The column of water between MASCONTROL and the highest tap must not exceed 70 feet.
- MASCONTROL unit operates from min 32 psi to the max pressure generated by the pump.

### **C - MASCONTROL preset cut-in pressure 42 psi model:**

- Max pressure generated by the pump at zero flow (Pump Shut Off Pressure) must be at least 75 psi.
- The column of water between MASCONTROL and the highest tap must not exceed 90 feet.
- MASCONTROL unit operates from min 42 psi to the max pressure generated by the pump.

In the event the pump pressure does not reach the value stated above, the unit will go into Failure mode and will not restart the pump.

In the event the high of the water column exceeds the level indicated, the unit will not restart the pump.

To overcome these problems install MASCONTROL at a higher level in order to recreate the above mentioned conditions, otherwise use higher cut-in pressure models.

# PRESSURE LOSS

**Pressure Loss Chart**

Flow rate	gpm	5	10	15	18	20	25	30	35	40
<b>MCA 1"</b>	psi loss	0.5	1.5	4	6.5	8.5	/	/	/	/
<b>MCB 1 1/4"</b>	psi loss	/	0.5	1.5	2.5	3.5	5.5	7.5	10	12.5

Use MASCONTROL in a by-pass when friction loss is excessive.

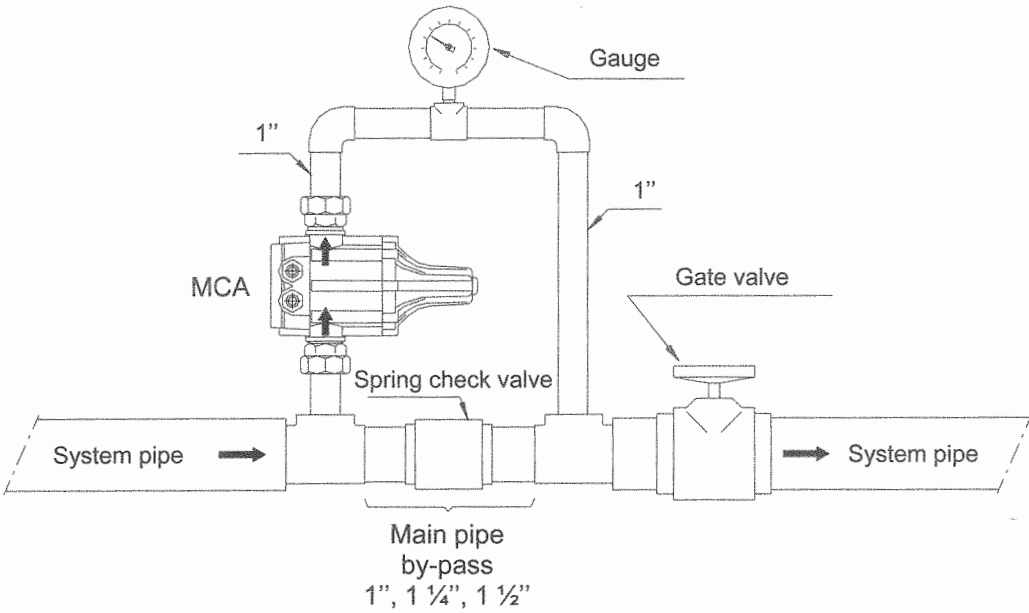

The main pipe of by-pass must not exceed 1 1/2", while the system pipe could be bigger.

**Pressure Loss Chart with a by-pass application**

Flow rate	gpm	20	30	40	50	60	70	80
<b>MCA x 1"</b>	psi loss	3	5	9	14	19	/	/
<b>MCA x 1 1/4"</b>	psi loss	2	2	3	5	8	10	12
<b>MCA x 1 1/2"</b>	psi loss	2	2	3	4	6	7	8

# TYPICAL MASCONTROL INSTALLATION ON SURFACE AND SUBMERSIBLE PUMPS

MASCONTROL can be installed on surface and submersible pumps for residential, domestic irrigation and booster systems.

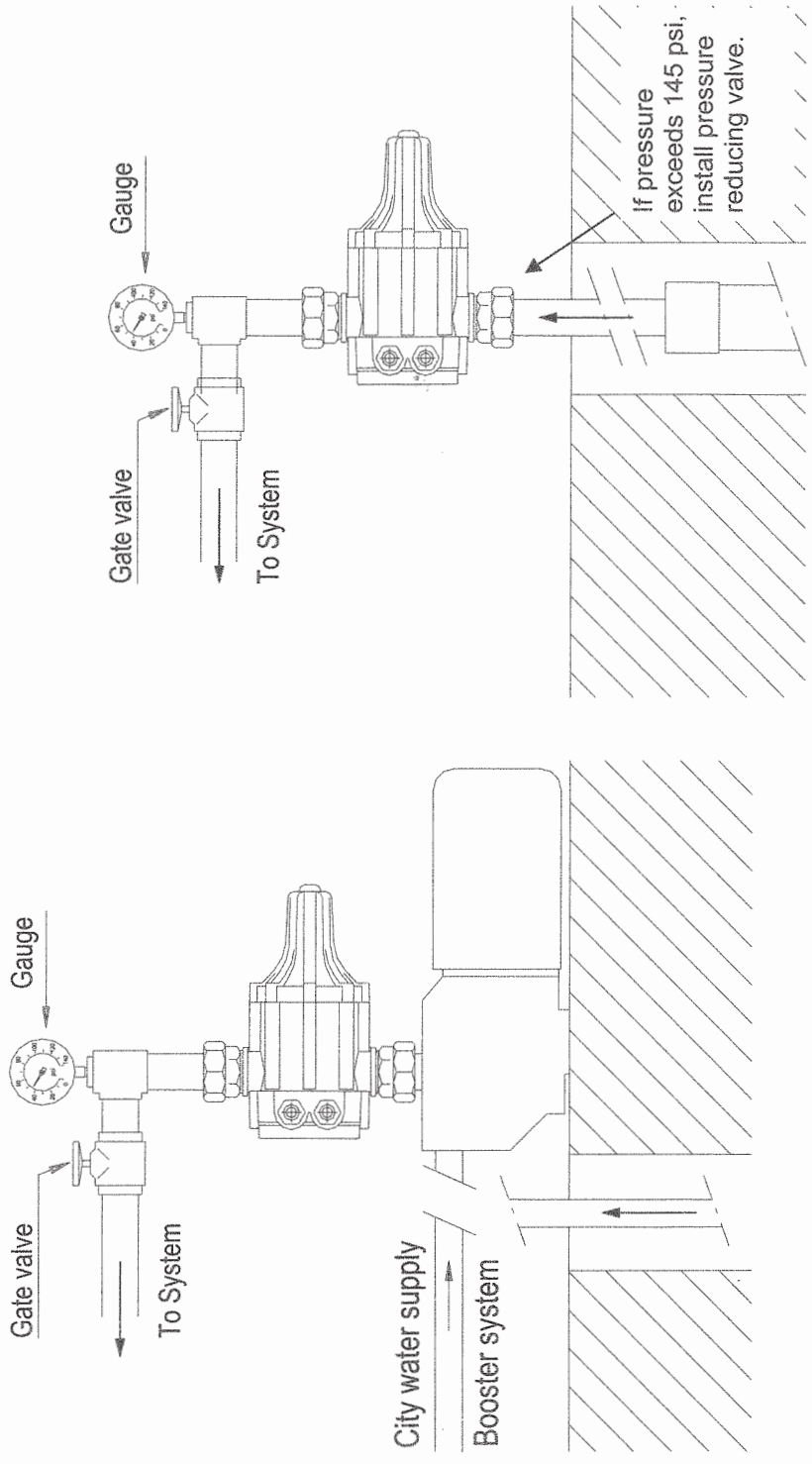

SURFACE PUMP

SUBMERSIBLE PUMP



## MASCONTROL INSTALLATION GUIDELINES AND WARNINGS

### PLEASE READ PRECAUTIONS AND WARNINGS ON PAGE 2 BEFORE PROCEEDING WITH INSTALLATION

- **MASCONTROL** operates the pump to its maximum pressure.
- Must always be installed in the vertical position, flow arrows up, electronic box level.
- Must always be installed between the pump and the first tap or tee.
- **Do not install any tap or tee between the pump and the MASCONTROL.**
- **Always install a gate valve and a pressure gauge after the MASCONTROL unit. This allows testing of the pump and MASCONTROL unit for efficiency and to confirm pump pressure.**
- Install a pressure reducing valve between pump and MASCONTROL when maximum pressure generated by the pump exceeds 145 psi.
- MASCONTROL's rated maximum operating pressure is 145 psi ( tested at 575 psi ).
- Use only Teflon tape for MASCONTROL connections. Pipe dope causes failures !
- Always confirm pump and system characteristics before installation, see page 5.
- Always confirm line pressure after installation. Install a pressure gauge between Mascontrol and gate valve.
- **Remove pressure switch from pump and wire MASCONTROL directly to pump.**
- Confirm electrical characteristics of pump motor before installation, e.g. full load amps and voltage.
- Install MASCONTROL only in clean water applications.

## MASCONTROL INSTALLATION WITH PRESSURE TANK OPTION

A small captive air tank ( 1/2 to 2 gallons ) may be used to supply a minimal flow demand such as a glass of water, ice maker machine, reverse osmosis systems, toilet flush, etc.

The small tank will feed the low flow application and substantially delay the pump start-up.

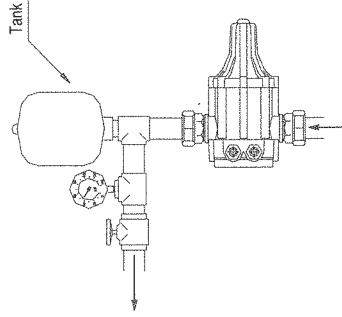

# ELECTRICAL CONNECTIONS



OBSERVE WARNINGS AND PRECAUTIONS LISTED AT THE FRONT OF THIS MANUAL.

Electrical connections should be made by a qualified professional in compliance with applicable local codes and National Electric Code.



**ALWAYS SHUT OFF POWER FOR INSTALLATION OR SERVICE.**

Check voltage of pump and supply to determine pump motor FLA and follow applicable MASCONTROL wiring diagram. If pump motor FLA exceeds MASCONTROL rating, use magnetic starter wiring diagram for the applicable voltage ( see pages 12, 13).



Use Copper Conductors only.  
Use 140 / 167 °F wire.  
Use minimum 13 AWG wire.  
Device must be properly grounded.

## IMPORTANT

Remove pressure switch from surface pump and wire MASCONTROL directly to pump.

### INSTALLATION WIRING DIAGRAM - 115VAC 2-WIRE PUMPS UP TO 16 FLA



For 115Vac motors exceeding 16 full load amps, use magnetic starter to avoid damage to MASCONTROL. ( See magnetic starter wiring diagram, pages 12, 13).

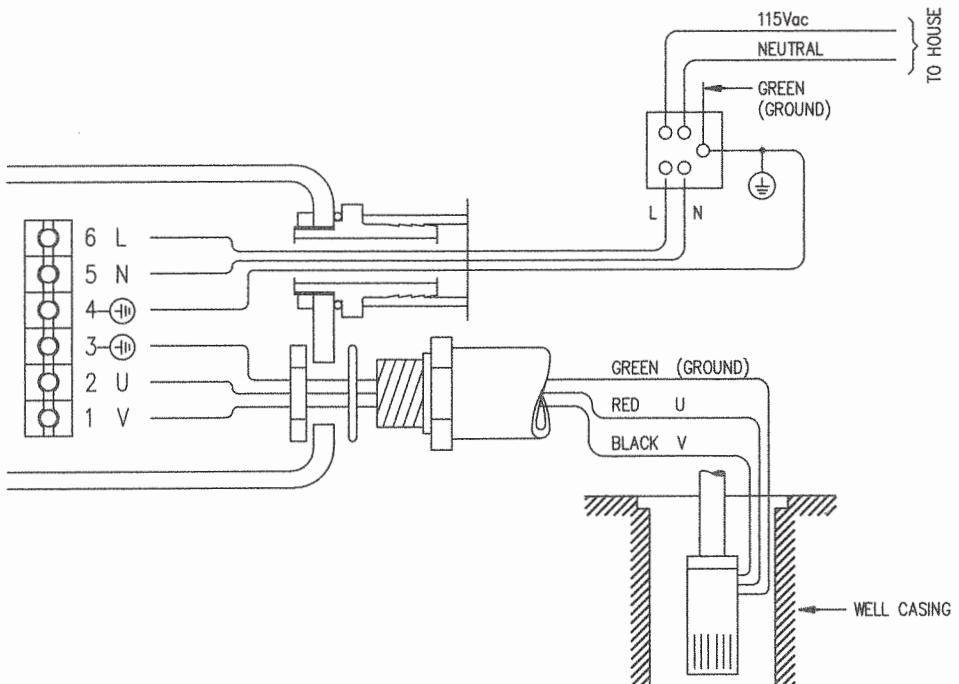

# INSTALLATION WIRING DIAGRAM - 230VAC - SINGLE PHASE 2-WIRE PUMPS UP TO 20 FLA



**WARNING**

For 230Vac motors exceeding 20 full load amps, use magnetic starter to avoid damage to MASCONTROL. ( See magnetic starter wiring diagram, pages 12, 13 ).

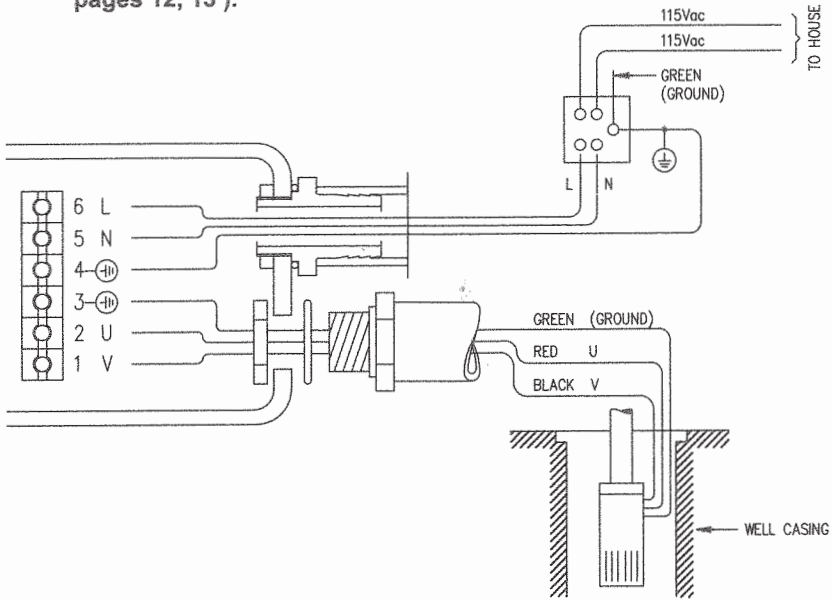

# INSTALLATION WIRING DIAGRAM - 230VAC - SINGLE PHASE 3-WIRE PUMPS UP TO 20 FLA



**WARNING**

For 230Vac motors exceeding 20 full load amps, use magnetic starter to avoid damage to MASCONTROL. ( See magnetic starter wiring diagram, pages 12, 13 ).

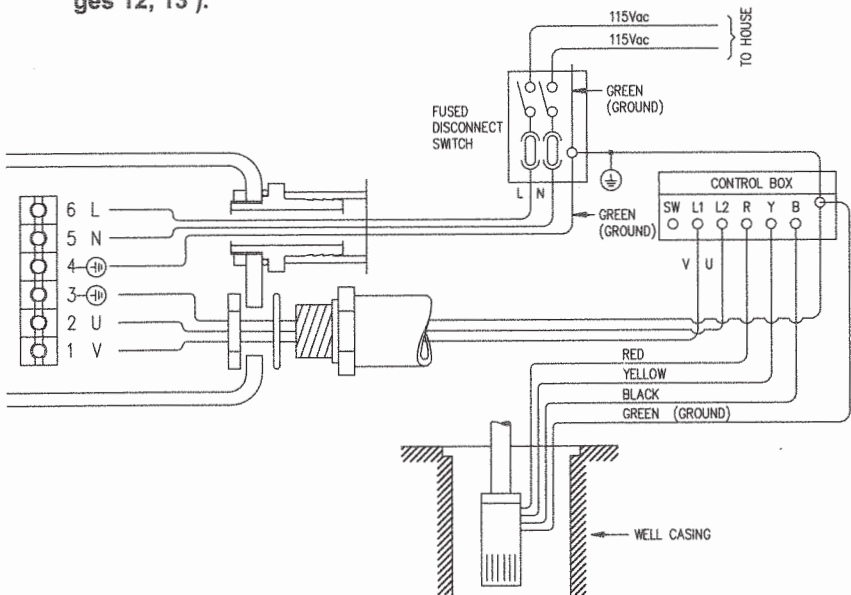

# WHEN TO USE CONTACTORS

Use a contactor when:

- On 115V installations pump motor full load amps exceed 16 FLA.
- On 230V installations pump motor full load amps exceed 20 FLA.
- On all three-phase applications.

Use of magnetic starter is determined by pump motor. If required, use contactor in conjunction with starter. **Remember**, match coil voltage on contactor with MASCONTROL voltage. Either 115V or 230V coils may be used.

## INSTALLATION WIRING DIAGRAM - 115 VAC 2-WIRE PUMPS EXCEEDING 16 FLA



**WARNING**

For 115Vac motors exceeding 16 full load amps, use magnetic starter to avoid damage to MASCONTROL.

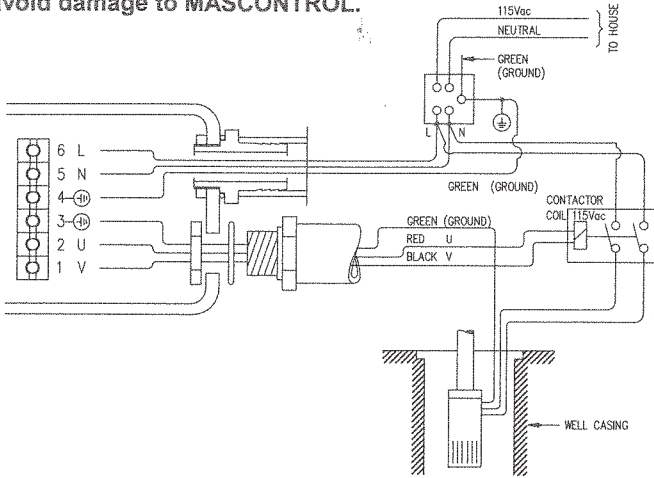

## INSTALLATION WIRING DIAGRAM - 230 VAC 2-WIRE PUMPS EXCEEDING 20 FLA

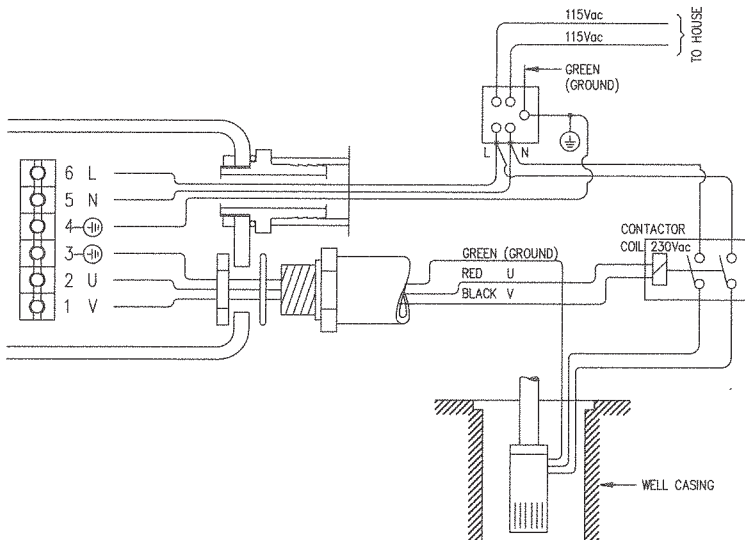

# INSTALLATION WIRING DIAGRAM - 208 VAC OR 230 VAC THREE PHASE - 3-WIRE PUMPS

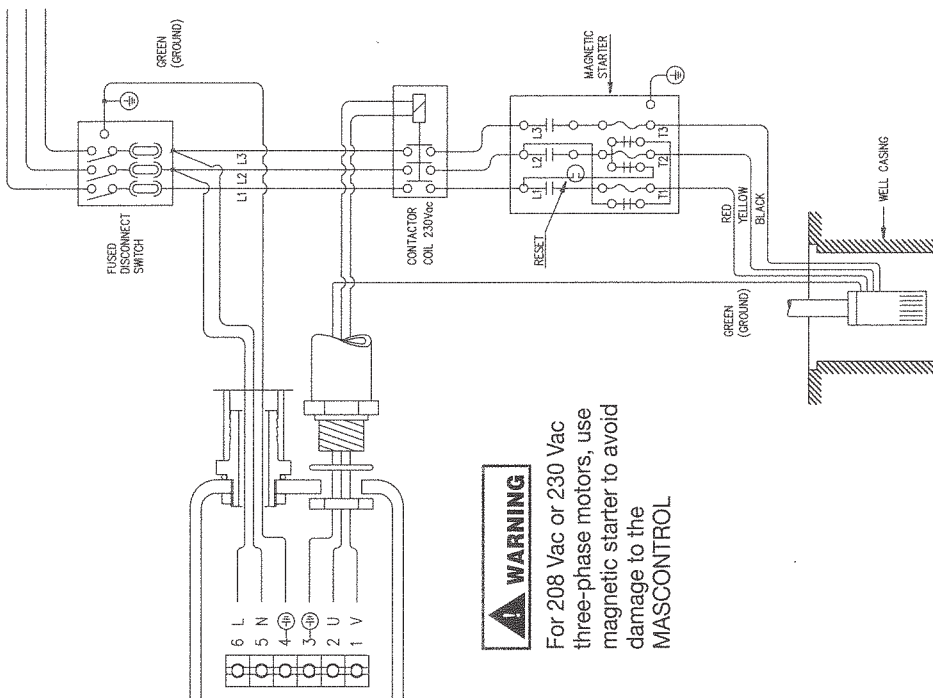

**WARNING**  
For 208 Vac or 230 Vac three-phase motors, use magnetic starter to avoid damage to the MASCONTROL

# INSTALLATION WIRING DIAGRAM - 460VAC

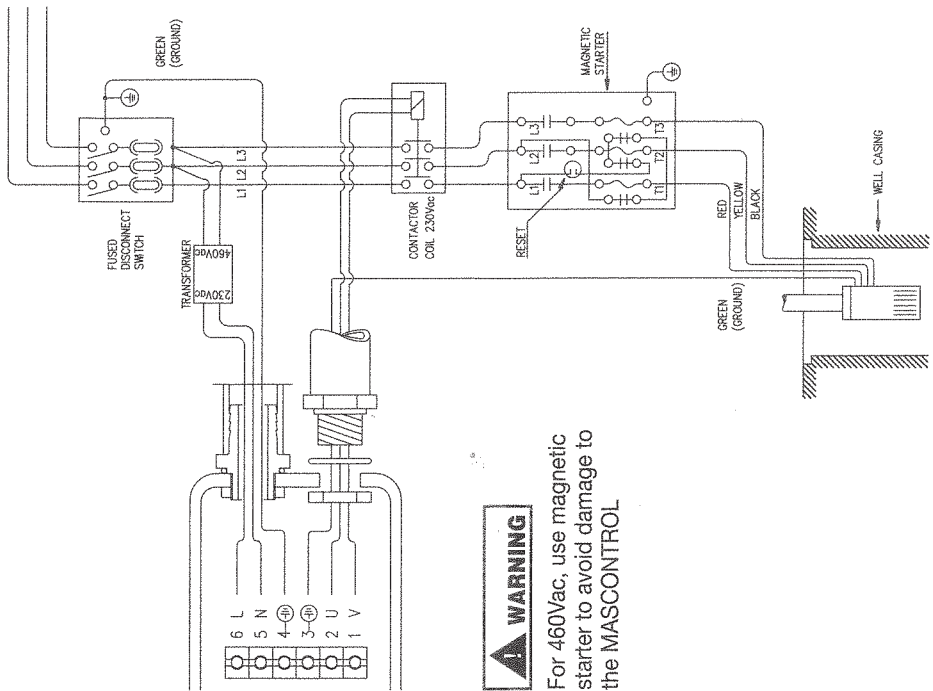

**WARNING**  
For 460Vac, use magnetic starter to avoid damage to the MASCONTROL

# INSTALLATION WIRING DIAGRAM - 230VAC - 3-WIRE PUMPS EXCEEDING 20 FLA

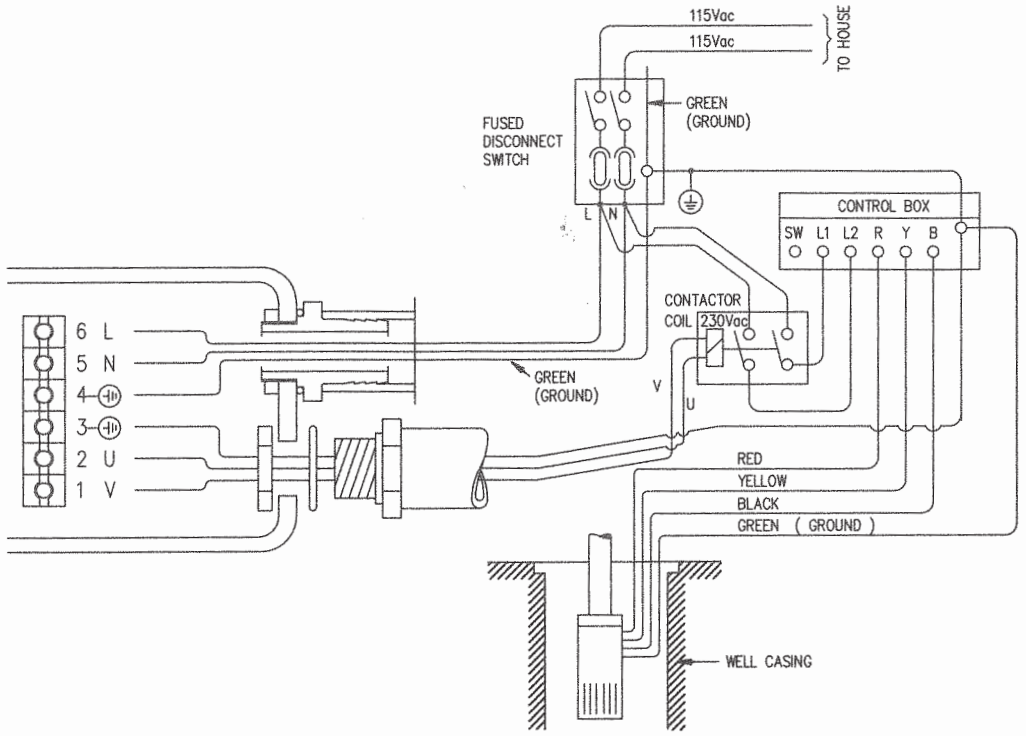

## OVERALL DIMENSIONS

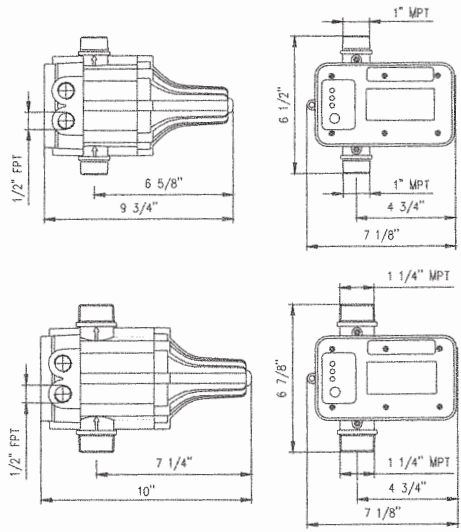

**Mod. MCA**

**Mod. MCB**

## ELECTRONIC BOX REPLACEMENT

**WARNING**

Prior to removing the electronic box ensure that power to unit is off and unit is depressurized.

1

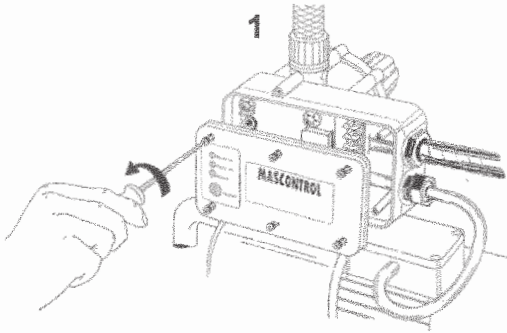

1) Remove the box cover and disconnect the electrical wires.

2

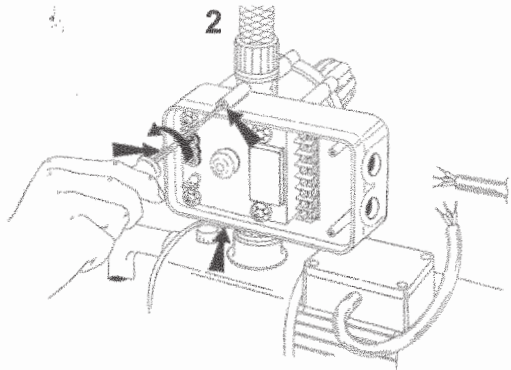

2) Take off the box by removing the three screws attaching the electronic box to the unit body.

3

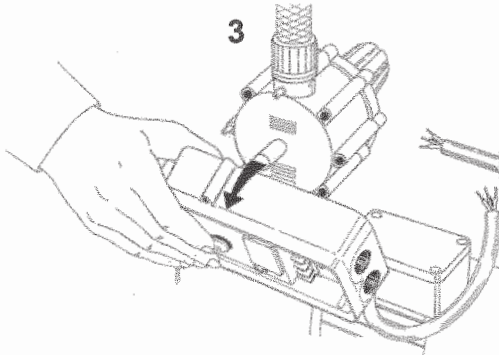

3) Remove the electronic box.

4

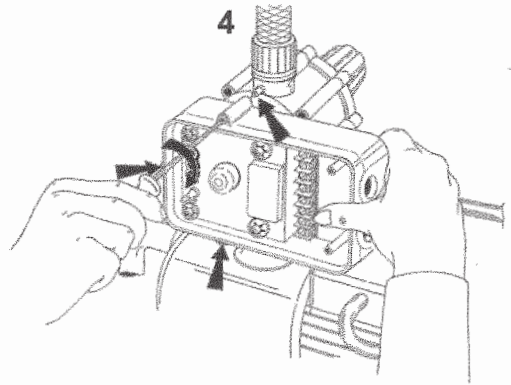

4) Install the new electronic box and tighten the three screws. Do not over-tighten or damage to threads may result.

5

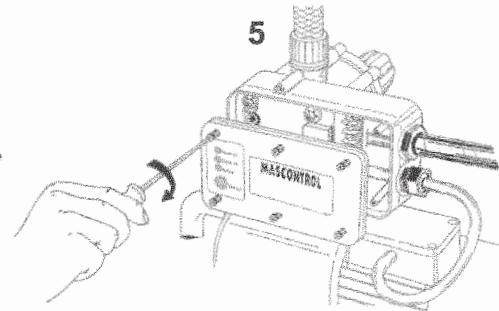

5) Tighten the six screws on the cover of the electronic box to ensure water tight seal.

**If cover is not securely fastened, RESET button will not operate.**

**WARNING: Do not turn on power until the box cover has been securely fastened.**

# MASCONTROL™

by TREVITECH

## DOMESTIC PUMP CONTROL

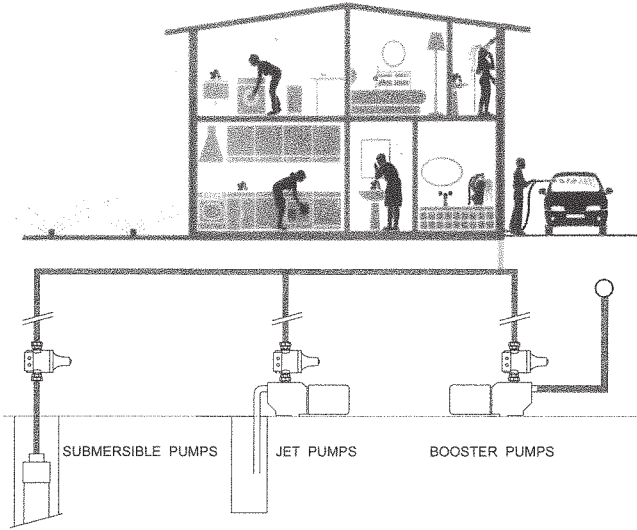

### WARRANTY

**THE WARRANTY PERIOD IS 1 YEAR FROM INSTALLATION DATE**

#### WARRANTY AND DISCLAIMER OF WARRANTY

The following warranty for the product is in lieu of all other conditions or warranties, whether express, implied or statutory, including but not limited to any implied conditions or warranties of merchantability or fitness for a particular purpose and on any implied conditions or warranty obligation on the part of manufacturer or its distributors, which are hereby expressly disclaimed. MASCONTROL is warranted to be free of defects occurring either in hydraulic or electronic parts for a period of one year from the date of installation when installed by a licensed professional in accordance with the product manual and due professional care. Manufacturer reserves the right to inspect and evaluate defective units prior to warranty claim settlement. Improper installation, application or mishandling of unit voids the warranty.

### PATENT INFRINGEMENT

MASCONTROL is protected under world-wide patents including the United States Patent Office. Any violation and or attempt to copy the MASCONTROL product in any part or form to the extent such copying or duplication in any part or form infringes upon the MASCONTROL patents will be swiftly and aggressively prosecuted.

U.S. Patent 5,259,733.

Locally distributed by: