

LANCASTER®

WATER TREATMENT

INSTALLATION, OPERATING AND SERVICE MANUAL

ELECTRONIC WATER FILTER TIME CLOCK MODEL FEATURING THE 2002F VALVE

COLOR, TASTE, ODOR

- | | |
|------------------------------------|-------------------------------------|
| <input type="checkbox"/> 7-LETCT-1 | <input type="checkbox"/> 7-LETCTG-1 |
| <input type="checkbox"/> 7-LETCT-2 | <input type="checkbox"/> 7-LETCTG-2 |
| <input type="checkbox"/> 7-LETCT-3 | <input type="checkbox"/> 7-LETCTG-3 |

IRON FILTER

- | | |
|------------------------------------|-------------------------------------|
| <input type="checkbox"/> 7-LETIM-1 | <input type="checkbox"/> 7-LETIMG-1 |
| <input type="checkbox"/> 7-LETIM-2 | <input type="checkbox"/> 7-LETIMG-2 |
| <input type="checkbox"/> 7-LETIM-3 | <input type="checkbox"/> 7-LETIMG-3 |

SEDIMENT/TURBIDITY

- | |
|------------------------------------|
| <input type="checkbox"/> 7-LETST-1 |
| <input type="checkbox"/> 7-LETST-2 |
| <input type="checkbox"/> 7-LETST-3 |

ACID NEUTRALIZERS

- | |
|---------------------------------------|
| <input type="checkbox"/> 7-LETDAN-1 |
| <input type="checkbox"/> 7-LETDAN-1.5 |
| <input type="checkbox"/> 7-LETDAN-2 |
| <input type="checkbox"/> 7-LETDAN-3 |
-

Congratulations on purchasing your new **Lancaster Water Filter**. This unit is designed to give you many years of trouble free service. For servicing and future inspection purposes, please file this booklet with your important documents.

In the event that you need assistance for servicing your water filter, please first contact the professional contractor who installed the system.

OPERATING PARAMETERS

Minimum / Maximum Operating Pressures	20 psi (138 kPa) - 125 psi (862 kPa)
Minimum / Maximum Operating Temperatures	40°F (4°C) - 110°F (38°C)
Current Draw & Voltage	0.5 Amperes - 110 Volts Other Options Available

GENERAL WARNINGS

The control valve, fittings and/or bypass are designed to accommodate minor plumbing misalignments but are not designed to support the weight of a system or the plumbing.

DO NOT use Vaseline, oils, other hydrocarbon lubrications or spray silicone anywhere. A silicone lubricant may be used on black o-rings but is not necessary. **Avoid any type of lubricants, including silicone, on red or clear lip seals.**

The nuts and caps are designed to be unscrewed or tightened by hand or with the optional maintenance wrench (p/n V3193). If necessary, pliers can be used to unscrew the nut or cap. **DO NOT** use a pipe wrench to tighten or loosen nuts or caps. **DO NOT** place screwdriver in slots on caps and/or tap with a hammer.

DO NOT use pipe dope or any other sealant on threads. Teflon tape must be used on the threads of the 1" NPT elbow or the 1/4" NPT connection and on the threads for the drain line connection. Teflon tape is not necessary on the nut connection or caps because of o-ring seals.

After completing any valve maintenance involving the drive assembly and pistons, unplug power source jack from the printed circuit (PC) board (black wire) and plug back in. This resets the electronics and establishes the service position.

All plumbing should be done in accordance with local plumbing codes. The pipe size of the drain line should be a minimum of 1/2". Backwash flow rates in excess of 7 gpm or length in excess of 20' require 3/4" drain line.

Solder joints near the drain must be done prior to connecting the drain line flow control fitting. Leave at least 6" between the drain line control and fitting solder joints when soldering pipes that are connected on the drain line control fitting.

Failure to do this could cause interior damage to the drain line flow control fitting.

When assembling the installation fitting package p/n V3007 (inlet and outlet - see page 9), connect the fitting to the plumbing system first and then attach the nut, split ring and o-ring. Heat from soldering or solvent cements may damage the nut, split ring or o-ring. Solder joints should be cool and solvent cements should be set before installing the nut, split ring and o-ring. **Avoid getting primer and solvent cement on any part of the o-rings, split rings, bypass valve or control valve.**

Plug into an electrical outlet. **NOTE:** All electrical connections must be connected according to local codes. (Be certain the outlet is uninterrupted.) Install grounding strap on metal pipes.

COMPONENTS:

MODEL	MINERAL TANK (dia. & ht.)	MIERAL- (QUANTITY OF BAGS)
7-LETDAN-1	FG1047DVT, 10 X 47 (with dome plug)	A8021 CALCITE - (2)
7-LETDAN-1.5	FG1054DVT, 10 X 54 (with dome plug)	A8021 CALCITE - (3)
7-LETDAN-2	FG1348DVT, 13 X 48 (with dome plug)	A8021 CALCITE - (4)
7-LETDAN-3	FG1365DVT, 13 X 65 (with dome plug)	A8021 CALCITE - (6)
7-LETIM-1	FG1044VT, 10 X 44	A8007 BIRM - (1)
7-LETIM-2	FG1348VT, 13 X 48	A8007 BIRM - (2)
7-LETIM-3	FG1465VT, 14 X 65	A8007 BIRM - (3)
7-LETCT-1	FG1044VT, 10 X 44	A8009 CARBON - (1)
7-LETCT-2	FG1348VT, 13 X 48	A8009 CARBON - (2)
7-LETCT-3	FG1465VT, 14 X 65	A8009 CARBON - (3)
7-LETST-1	FG1044VT, 10 X 44	A8014 FILTER AG - (1)
7-LETST-2	FG1348VT, 13 X 48	A8014 FILTER AG - (2)
7-LETST-3	FG1465VT, 14 X 65	A8014 FILTER AG - (3)

INSTALLATION

Place filter in desired location close to water supply inlet, after pressure tank, and near a source for waste water, (utility sink, floor drain or sewer line). A 115/120V, 60Hz uninterrupted outlet is required. Keep filter far enough away from walls and other obstructions to allow enough room for servicing the unit. If a water softener is also to be installed, generally it will be placed in line after the neutralizer or filter.

From water supply → neutralizer → filter → softener → to service

ADD MINERALS:

Remove control valve from mineral tank by turning counter-clockwise. Plug open end (top) of distributor tube assembly to prevent mineral from entering (**Fig. A**). Add Mineral. **DO NOT OVERFILL**. There must be at least 16" of space between the top of the tank and mineral (**Fig. B**). Remove plug from the top of the distributor tube.

Install control valve making sure the distributor tube is slipped into the center hole on the bottom of the control valve. Pipe filter into service line. Use of a bypass valve is recommended. Arrows are molded into valve and bypass valve to show direction of flow.

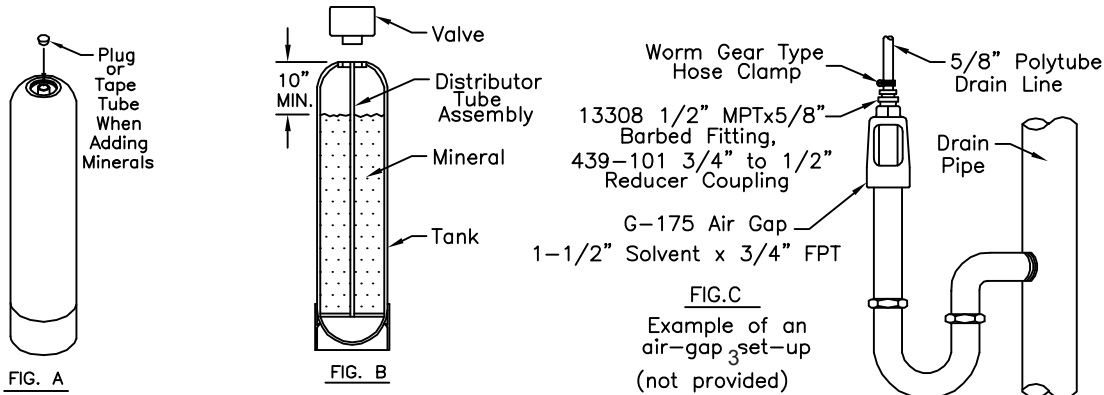

OPTIONAL BYPASS VALVE: The bypass valve easily connects to the control valve body using nuts that only require hand tightening. Install with red knobs in the upward position. Press end of bypass valve with o-rings into valve. Hand tighten nuts. Place into **BYPASS OPERATION (Fig. 4)**.

Avoid getting primer and solvent cement on any part of the o-rings or split rings, bypass valve or control valve. **DO NOT** use pipe dope or any other sealant on threads. Teflon tape is not necessary on the caps because of o-ring seals. **DO NOT** use Vaseline or other unacceptable lubricants on o-rings. A silicone lubricant may be used on black o-rings.

DRAIN LINE: The 3/4" drain line elbow accommodates 5/8" poly tube or 3/4" NPT drain line connections. The nut and poly tube insert for the 3/4" drain line elbow is designed for use with flexible, semi-rigid poly tube only. The drain line elbow can be rotated so the outlet can be oriented toward the nearest drain.

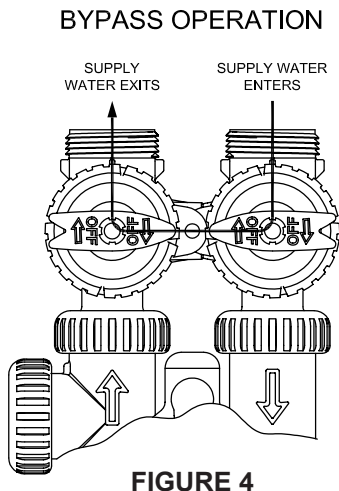

TO INSTALL 5/8" POLY TUBE DRAIN LINE: The poly tube insert is shipped attached to the drain line elbow's locking clip. Press the insert into the drain line (5/8" poly tube not included). Loosen nut of the drain line elbow. Press 5/8" poly tube with insert into the drain line elbow until it seats on the back of the fitting. Tighten nut.

The drain line must be piped to an open drain with air gap between the drain and the sewer lines (Fig. 3). Under no circumstances should there be a direct connection with sanitary sewage facilities. If it is necessary to run the drain pipe overhead, (not to exceed 5' above valve) be sure to increase the pipe size and follow all plumbing procedures to hold friction and restrictions to a minimum.

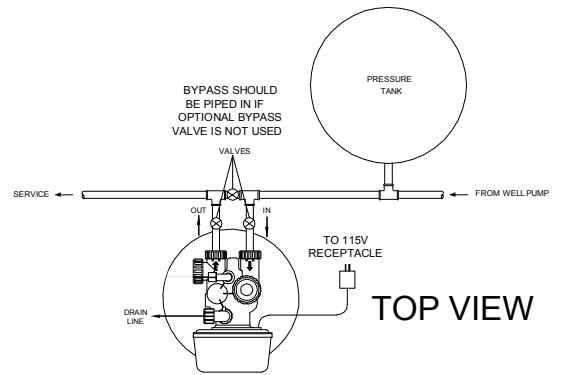

PROGRAMMING THE CONTROL VALVE: Note: A quick-reference card is stored inside the front cover of the control valve. To access this card, slightly pull tabs on side of cover outward and pull cover forward. Plug the electrical cord into a 115 Volt receptacle. **DO NOT** plug into an outlet controlled by a wall switch or pull chain that could inadvertently be turned off. Wait a couple of seconds for control valve to “home” itself. The time of day will be flashing, an arrow will be pointing to “Time-Hour”.

SET TIME OF DAY

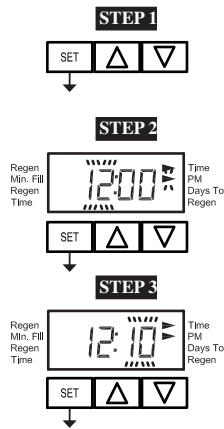

STEP 1: Press and Hold **SET** for 3 seconds.

STEP 2: Current time: Adjust hour with ▲ or ▼. With 60 Hz line frequency detection on power-up, timekeeping is 12 hour with PM indicator. Press **SET** to go to Step 3.

STEP 3: Adjust minutes with ▲ or ▼. Press **SET** to exit Set Time of Day.

POWER LOSS: Only the current time of day will need to be reset if power is lost for greater than 8 hours. If power is lost while the system is regenerating, the control will complete regeneration at the point of interruption once power is restored.

ERROR MESSAGE: if “E1”, “E2”, “E3” or “E4” appears on the display contact the OEM for help. This indicates that the valve did not function properly.

SET REGENERATION TIME AND DAYS BETWEEN BACKWASHES

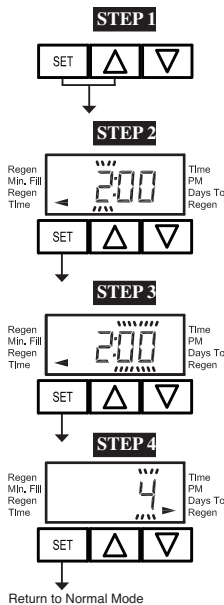

STEP 1: From normal mode, press **SET + ▲** buttons simultaneously for 3 seconds and release.

STEP 2: Backwash Time Hour: Set the time for backwash to start using ▲ or ▼. Press **SET** to go to the next step.

STEP 3: Backwash Time Minutes: Set the time for backwash start using ▲ or ▼. Press **SET** to go to the next step.

STEP 4: Days to Backwash: Set the number of days between backwash. The allowable range is 1 to 99. Press **SET** to exit.

PLACING UNIT INTO SERVICE: Make sure inlet and outlet valves are to their closed positions. If using optional bypass, place in bypass position. Turn on main water supply. Open a cold water faucet. This will clear the lines of any debris (solder, pipe dope, etc.) that may be in the line. Let water run at tap for a couple of minutes, or until clear. Turn off faucet.

- Press and hold the ▲ and ▼ buttons simultaneously for approximately 5 seconds until the motor starts. Wait until display reads **C1**. This is the first **BACKWASH** position.
- If using optional bypass **SLOWLY** turn bypass valve to **DIAGNOSTIC MODE** (Fig. 5) or slowly open inlet valve to allow water to slowly enter the filter.
- When water is flowing steadily to drain without the presence of air and no mineral “FINES” are seen, momentarily press ▲ button again. Display will read **C4**. This is the final rinse position.
- Open the outlet valve of the filter, or if using optional bypass place to **NORMAL OPERATION MODE** (Fig. 6).
- Momentarily press ▲ button again. **C0** will appear for a few seconds while control valve returns to the filtering position.

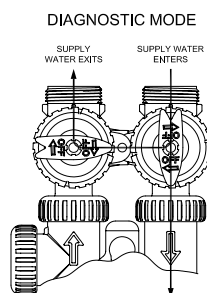

FIGURE 5

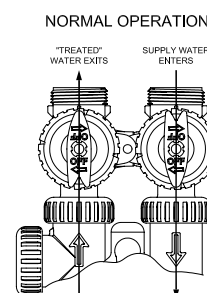

FIGURE 6

**ADDITIONAL PROGRAMMING INFORMATION AVAILABLE FROM
LANCASTER WATER TREATMENT UPON REQUEST.
INCLUDES: 7-DAY OPTION, REGENERATION CYCLES, TIMES AND 50 Hz.**

SERVICE INSTRUCTIONS

ACID NEUTRALIZERS, (7-LETDAN-): Mineral used: Calcite. Calcite will dissolve in proportion to the amount of acid in the raw water. The amount of calcite in the tank should be monitored and replaced periodically. A tank with a dome plug is provided so that calcite may be added without removing the control valve. To check level of calcite in the mineral tank **shut off water supply to the filter**. Press and hold the ▲ and ▼ buttons until the filter goes into backwash. Unplug valve from power supply. This will relieve the pressure in the tank. Remove hexagonal dome plug. A small amount of water will be lost from the tank. Insert a dipstick into the dome hole until the stick reaches mineral level. Mark and remove the stick. Measure the marked distance on the stick. This number should never be less than 16". Replace calcite before the mineral level is 24" from the dome hole. Adding calcite will displace the water in the tank. This water may be siphoned out to reduce spillage. As each installation will use a different amount of calcite, monitoring the mineral level once a month for the first few months of operation should give a fairly good indication as to how frequently the calcite will need to be replenished. Replace the dome plug. Turn on the water supply to the neutralizer. Plug valve into power supply. Allow water to run to drain for a couple of minutes to allow "Fines" to backwash to drain. Press and release the ▲ button. Display will read **C4**. Press and release the ▲ button again. Time of day will need to be reset.

A pH test kit may also be used to monitor the pH level to help determine when mineral needs to be replenished. Calcite will add approximately four (4) or more grains per gallon to the original hardness of the raw water. This should be kept in mind when figuring regeneration cycle for a water softener. If a Corosex/Calcite mixture is recommended to be used (for high flow rates or very low pH level), mix one part Corosex with four parts Calcite **BEFORE** adding to the tank. **NOTE: 1 cu ft. of calcite = 85 lbs.**

IRON FILTERS, (7-LETIM-, 7-LETIMG-): Mineral used: Birm. No chemical regenerant is required, backwash periodically. No hardness is added to the water. For clear water iron, when the pH is less than seven (7) in the raw water, a water softener should be used in place of the iron filter. **Note: When using Birm for iron removal, it is necessary that the water: contain no oil or hydrogen sulfide, organic matter not to exceed 4-5 ppm, the D.O. content equal at least 15% of iron content with a pH of 6.8 or more. If the influent water has a pH of less than 6.8, neutralizing additives such as Calcite, Corosex or soda ash may be used prior to the Birm filter to raise the pH. A water having a low D.O. level may be pretreated by aeration. Chlorination greatly reduces Birm's activity. High concentrations of chlorine compounds may deplete the catalytic coating.**

COLOR, TASTE AND ODOR FILTERS, (7-LETCT-, LETCTG-): Mineral used: Carbon. Used for removal of chlorine, color, taste, odor and low levels of sulfur, etc. The mineral bed should be backwashed periodically, but will in time reach the maximum absorbency. When this occurs the carbon should be completely replaced.

SEDIMENT AND TURBIDITY, (7-LETST-): Mineral used: Filter AG. This filter will filter out dirt, silica, etc. down to the 20-40 micron range. In most cases it has a lifetime fill and should be backwashed periodically depending on local conditions. Pressure drop is very low.

DRIVE ASSEMBLY:

Remove the valve cover to access the drive assembly.

Disconnect the power source plug (black wire) from the PC board prior to disconnecting the motor plug from the PC board. The motor plug connects to the two-pin jack on the left-hand side of the PC board. The power source plug connects to the four-pin jack.

The PC board can be removed separately from the drive bracket but it is not recommended. Do not attempt to remove the display panel from the PC board. Handle the board by the edges. To remove the PC board from the drive bracket, unplug the power and motor plugs from the PC board. Lift the middle latch along the top of the drive bracket while pulling outward on the top of the PC board. The drive bracket has one plastic pin that fits into the hole in the lower edge of the PC board. Once the PC board is tilted about 45° from the drive bracket it can be lifted off the pin. To reinstall the PC board, position the lower edge of the PC board so that the hole in the PC board lines up with the plastic pin. Push the top of the PC board towards the valve. Align the upper hole on the left hand side of the PC board with the pin and push in until the PC board snaps under the middle latch, weave the power wire into the holders and reconnect the motor and power plugs.

The drive bracket must be removed to access the drive cap assembly and pistons or the drive gear cover. It is not necessary to remove the PC board from the drive bracket to remove the drive bracket. To remove the drive bracket start by removing the plug for the power source. Unweave the wire from the side holders. Two tabs on the top of the drive back plate hold the drive bracket in place. Simultaneously lift the two tabs and gently ease the top of the drive bracket toward your body. The lower edge of the drive bracket has two notches that rest on the drive back plate. Lift up and outward on the drive bracket to disengage the notches.

To reassemble seat the bottom of the drive bracket so the notches are engaged at the bottom of the drive back plate. Push the top of the drive bracket towards the two latches. The drive bracket may have to be lifted slightly to let the threaded piston rod pass through the hole in the drive bracket. Maintain a slight engaging force on the top of the drive bracket while deflecting the bracket slightly to the left by pressing on the side of the upper right corner. This helps the drive gears mesh with the drive cap assembly. The drive bracket is properly seated when it snaps under the latches on the drive back plate. If resistance is felt before latching, then the notches are not fully engaged, the piston rod is not in the hole, the power wire is jammed between the drive bracket and the drive plate, or the gear is not engaging the drive cap assembly.

DRIVE ASSEMBLY CONTINUED

To inspect drive gears, the drive gear cover needs to be removed. The drive gear is held in place on the drive bracket by three clips. The largest of the three clips is always oriented to the bottom of the drive bracket. Before trying to remove the drive gear cover, the drive bracket must be removed from the drive back plate. The drive gear cover can be removed from the drive bracket without removing the PC board. Simultaneously, push in and down on the large clip at the bottom and the clip on the left-hand side of the drive bracket behind the PC board. Keep your other fingers behind the drive gear cover so the drive gears do not drop on the ground.

Replace broken or damaged drive gears. Do not lubricate any of the gears. Avoid getting any foreign matter on the reflective coating because dirt or oils may interfere with pulse counting.

The drive gear cover only fits on one way, with the large clip oriented towards the bottom. If all three clips are outside of the gear shroud on the drive bracket the drive gear cover slips easily into place.

The drive bracket does not need to be removed from the drive plate if the motor needs to be removed. To remove the motor, disconnect the power and motor plugs from the jacks on the PC board. Move the spring clip loop to the right and hold. Rotate the motor at least a $\frac{1}{4}$ turn in either direction before gently pulling on the wire connectors to remove the motor. Pulling directly on the wire without rotating the motor may break the wires off the motor.

Replace the motor is necessary. Do not lubricate the motor or the gears. When reinstalling the motor gently turn the motor while inserting so that the gear on the motor meshes with the gears under the drive gear cover and the small plastic plug engages one of the slots on the motor housing. Reconnect the motor plug to the two pronged jack on the lower left-hand side of the PC board. If the motor will not easily engage with the drive gear when reinstalling, lift and slightly rotate motor before reinserting.

Replace the valve cover. After completing any valve maintenance, press and hold **SET HOUR** and ▼ buttons for 5 seconds or unplug power source jack (black wire) from the circuit board and plug back in. This resets the electronics and establishes the filtering position. Reset the time of day.

DRIVE CAP ASSEMBLY, MAIN PISTON AND REGENERANT PISTON:

The drive assembly must be removed to access the drive cap assembly. The drive cap assembly must be removed to access the piston(s). The drive cap assembly is threaded into the control valve body and seals the o-ring. To remove the drive cap assembly use the optional maintenance wrench or insert a $\frac{1}{4}$ " to $\frac{1}{2}$ " flat bladed screwdriver into one the slots around the top 2" of the drive cap assembly so it engages the notches molded into the drive back plate around the top 2" of the piston cavity (see drawing below). The notches are visible through the holes. Lever the screwdriver so the drive cap assembly turns counter clockwise. Once loosened unscrew the drive cap assembly by hand and pull straight out.

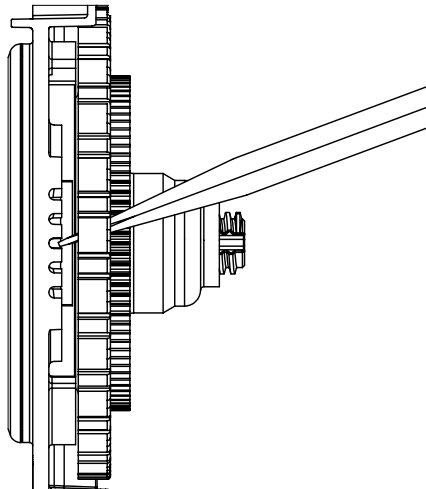

The drive cap assembly contains the drive cap, the main drive gear, drive cap spline, piston rod and various other parts that should not be disassembled in the field. The only replaceable part on the drive cap assembly is the o-ring. Attached to the drive cap assembly is the main piston and, if a regenerant is used, a regenerant piston.

The regenerant piston (the small diameter one behind the main piston) is removed from the main piston by unsnapping it from its latch. Chemically clean in dilute sodium bisulfite or vinegar or replace the regenerant piston if needed. To remove the main piston fully extend the piston rod and then unsnap the main piston from its latch by pressing on the side with the number. Chemically clean in diluted sodium bisulfite or vinegar or replace the main piston.

Reattach the main piston to the drive cap assembly. Reattach the regenerant piston (if needed) to the main piston. Do not lubricate the piston rod, main piston or regenerant piston. Lubricant will adversely affect the red or clear lip seals. Reinsert the drive cap assembly and piston into the spacer stack assembly and hand tighten the drive cap assembly. Continue to tighten the drive cap assembly using the maintenance wrench or screwdriver as a ratchet until the black o-ring on the spacer stack assembly is no longer visible through the drain port. Excessive force can break the notches molded into the drive back plate. Make certain the main drive gear still turns freely. The exact position of the piston is not important as long as the main drive gear turns freely.

Reattach the drive assembly to the control valve and connect all plugs. After completing any valve maintenance, press and hold **SET HOUR** and ▼ buttons for 5 seconds or unplug power source jack (black wire) from the circuit board and plug back in. This resets the electronics and establishes the filtering position. Reset the time of day.

SPACER STACK ASSEMBLY:

To access the spacer stack assembly remove the drive assembly, drive cap assembly and piston. The spacer stack assembly can be removed easily without tools by using your thumb and forefinger. Inspect the black o-rings and red or clear lip seals for wear or damage. Replace the entire stack if necessary. The spacer stack assembly has been 100% tested at the factory to insure proper orientation of one way seals. **DO NOT** disassemble spacer stack.

The spacer stack assembly may be chemically cleaned (dilute sodium bisulfite or vinegar) or wipe with a soft cloth.

The spacer stack assembly can be pushed into the control valve body bore by hand. Since the spacer stack assembly can be compressed it is easier to use a blunt object ($\frac{5}{8}$ " to $1\frac{1}{8}$ " in diameter) to push the center of the assembly into the control valve body. The assembly is properly seated when at least four threads are exposed (approximately $\frac{5}{8}$ ") **DO NOT** force the spacer stack assembly in. The control valve body bore interior can be lubricated with silicone to allow for easy insertion of the entire stack. Do not use silicone or any other type of lubricant on the red or clear lip seals or the piston.

Reattach the drive cap assembly and piston(s) and the drive assembly.

After completing any valve maintenance, press and hold **SET HOUR** and ▼ buttons for 5 seconds or unplug power source jack (black wire) from the circuit board and plug back in. This resets the electronics and establishes the filtering position. Reset the time of day.

INJECTOR CAP, SCREEN, INJECTOR PLUG AND INJECTOR:

Unscrew the injector cap and lift off. Loosen cap with optional maintenance wrench or pliers if necessary. A screen is attached to the injector cap. Remove the screen and clean if fouled.

The plug and/or injector can be pried out with a small screwdriver. The plug can be wiped clean. If the plug leaks replace the entire plug. The injector consist of a throat and a nozzle. Chemically clean the injector with vinegar or dilute sodium bisulfite. The holes can be blown out with air. Both pieces have small diameter holes that control the flow rates of the water to insure that the proper concentration of the regenerant is used. Sharp objects, which can score the plastic, should not be used to clean the injector. Scoring the injector or increasing the diameter of the hole could change the operating parameters of the injector.

Two holes are labeled DN and UP. For down flow systems, the appropriate injector is located in the "DN" hole, a plug is in the "UP" hole. Push the plug and injector firmly in place, replace the screen and hand tighten the injector cap.

REFILL FLOW CONTROL ASSEMBLY OR REFILL PORT PLUG:

To clean or replace the refill flow control, pull out the elbow-locking clip and then pull straight up on the elbow. Replace the elbow locking clip in the slot so that it is not misplaced. Twist to remove the white flow control retainer. The flow control can be removed by prying upward through the side slots of the retainer with a small blade flat screwdriver.

Chemically clean the flow control or the white flow control retainer using dilute sodium bisulfite or vinegar. Do not use a wire brush. If necessary, replace the flow control, o-ring on the flow control retainer, or the o-ring on the elbow.

Reseat the flow control so the rounded end is visible in the flow control. Reseat the white flow control retainer by pushing the retainer into the elbow until the o-ring seats. Remove locking clip, push down on elbow to reseat and insert locking clip.

DO NOT use Vaseline, oils, or other unacceptable lubricants on o-rings. A silicone lubricant may be used on the o-ring on the elbow or white retainer.

METER PLUG:

This control valve does not come equipped with a meter, instead a plug is installed. The plug should not need to be serviced.

To remove the meter plug assembly, unscrew the meter cap on the left side of the control valve. Pliers may be used to unscrew the nut if necessary.

With the nut removed, a slot at the top of the meter plug is visible. Twist a flat blade screwdriver in the slot between the control valve body and the meter plug. When the meter plug is part way out it is easy to remove the meter plug from the housing.

DO NOT use a wire brush to clean. Wipe with a clean cloth or chemically clean in dilute sodium bisulfite or vinegar.

DO NOT use Vaseline, oils, or other unacceptable lubricants on o-rings. A silicone lubricant may be used on the black o-ring.

Reinsert the meter plug into the side slot. Hand tighten the nut. Do not use a pipe wrench to tighten nut.

BYPASS VALVE:

The working parts of the bypass valve are the rotor assemblies that are contained under the bypass valve caps. Before working on the rotor, make sure the system is depressurized. Turn the red arrow shaped handles toward the center of the bypass valve and back to the arrow direction several times to ensure rotor is turning freely.

The nuts and caps are designed to be unscrewed or tighten by hand. If necessary a pliers can be used to unscrew the nut or cap. **DO NOT** use a pipe wrench to tighten or loosen nuts or caps. **DO NOT** place screwdriver in slots on caps and/or tap with a hammer. To access the rotor, unscrew the cap and lift the cap, rotor and handle out as one unit. Twisting the unit as you pull it out will help to remove it more easily. There are three o-rings: under the bypass cap, on the rotor stem and on the rotor seal. Replace worn o-rings. Clean rotor. Reinstall rotor.

When reinstalling the red arrow handles be sure that:

1. O-rings on both rotors face to the right when being viewed from the front of the control valve when the handle pointers are lined up with the control valve body arrows; or
2. Arrows point toward each other in the bypass position.

Since the handles can be pulled off, they could be accidentally reinstalled 180° from their correct orientation. To install the red handles correctly, keep the handles pointed in the same direction as the arrows engraved on the control valve body while tightening the bypass valve caps.

After completing any valve maintenance, press and hold **SET HOUR** and ▼ buttons for 5 seconds or unplug power source jack (black wire) from the circuit board and plug back in. This resets the electronics and establishes the filtering position. Reset the time of day.

OPTIONAL MAINTENANCE WRENCH

V3193

Although no tools are necessary to assemble the valve, the optional maintenance wrench (shown in various positions on the valve) may be purchased to aid in assembly or disassembly.

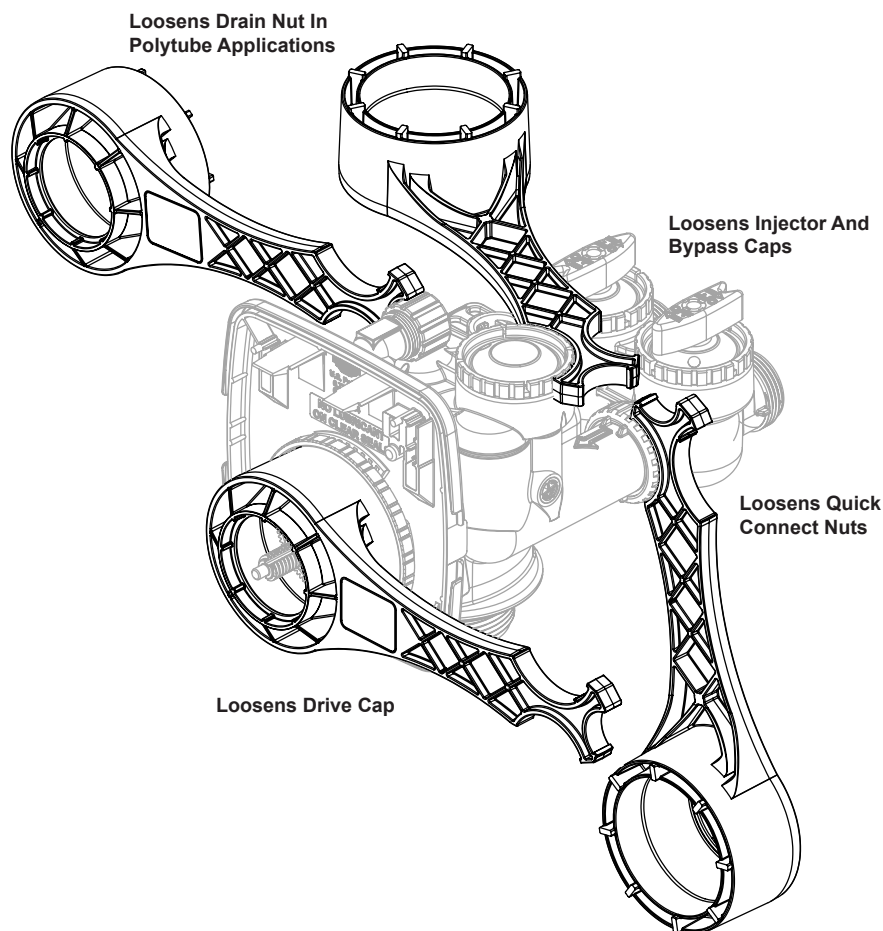

PARTS

V3007 1" PVC Male NPT Elbow Assembly Standard

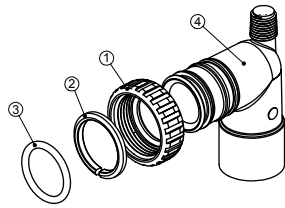

Item No.	Quantity	Part No.	Description
1	2	V3151	Nut 1" Quick Connect
2	2	V3150	Split Ring
3	2	V3105	O-Ring 215
4	2	V3149	1" PVC Male NPT Elbow

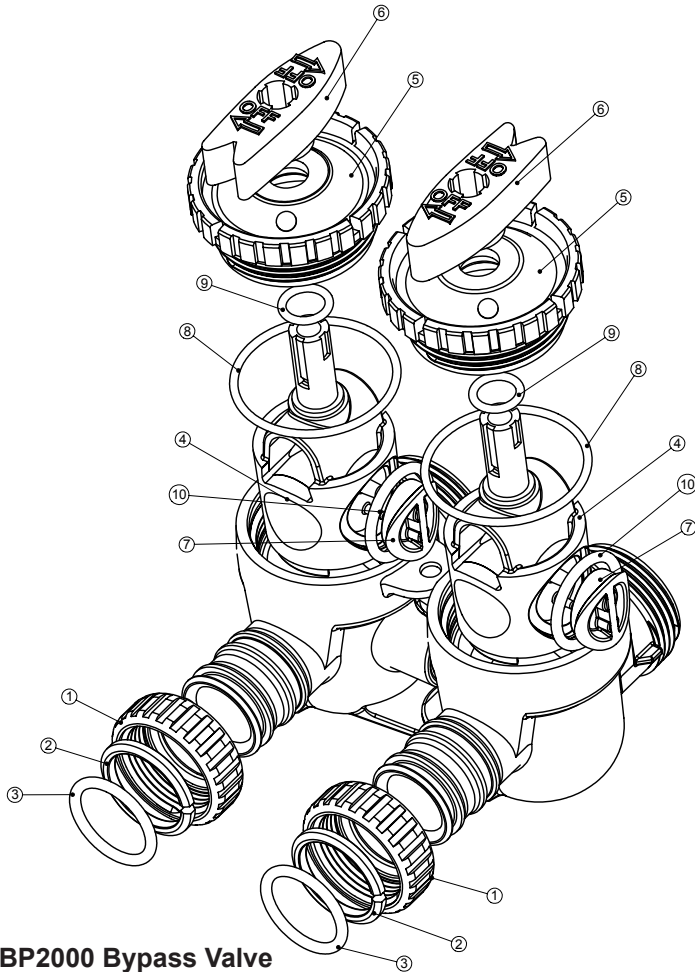

BP2000 Bypass Valve

Item No.	Quantity	Part No.	Description
1	2	V3151	Nut 1" Quick Connect
2	2	V3150	Split Ring
3	2	V3105	O-Ring 215
4	2	V3145	Bypass 1" Rotor
5	2	V3146	Bypass Cap
6	2	V3147	Bypass Handle
7	2	V3148	Bypass Rotor Seal Retainer
8	2	V3152	O-Ring 135
9	2	V3155	O-Ring 112
10	2	V3156	O-Ring 214

V3007-02 1" Brass Sweat Assembly Optional

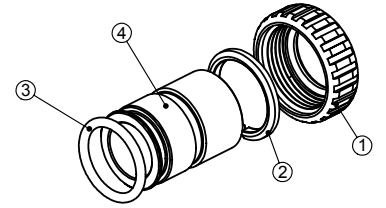

Item No.	Quantity	Part No.	Description
1	2	V3151	Nut 1" Quick Connect
2	2	V3150	Split Ring
3	2	V3105	O-Ring 215
4	2	V3188	Fitting - 1" Brass Sweat

V3007-03 3/4" Brass Sweat Assembly Optional

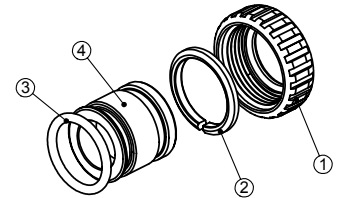

Item No.	Quantity	Part No.	Description
1	2	V3151	Nut 1" Quick Connect
2	2	V3150	Split Ring
3	2	V3105	O-Ring 215
4	2	V3188	Fitting - 3/4" Brass Sweat

V3191-01 Vertical Adapter Assembly Optional

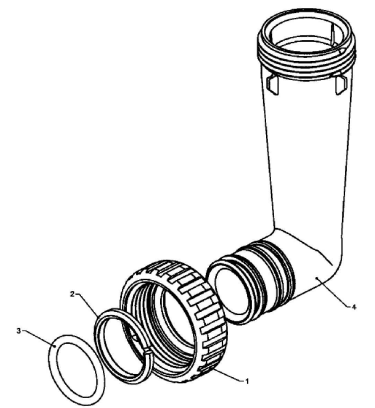

Item No.	Quantity	Part No.	Description
1	2	V3151	Nut 1" Quick Connect
2	2	V3150	Split Ring
3	2	V3105	O-Ring 215
4	2	V3191	Vertical Adapter

When replacing the battery, align positives and push down to fully seat.



Correct Battery Orientation

Battery replacement is 3 volt lithium coin cell type 2032.

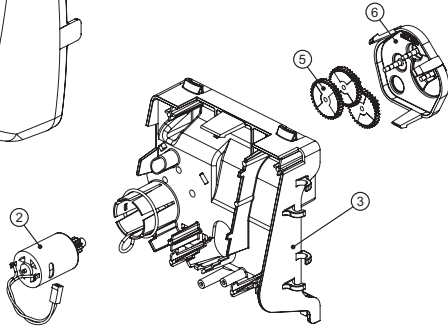
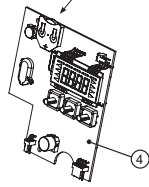
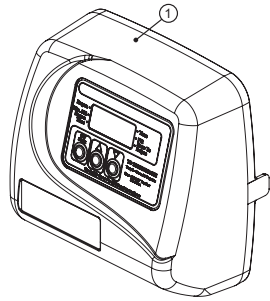

FRONT COVER AND DRIVE ASSEMBLY

Item No.	Quantity	Part No.	Description
1	1	V3175TC	Front Cover Assembly
2	1	V3107	Motor
3	1	V3106	Drive Bracket/Spring Clip
4	1	V3108TC	PC Board
5	3	V3110	Drive Gear Cover
6	1	V32109	Drive Assembly
2-6	*	V3002TC	Drive Assembly (parts 2-6)
NOT SHOWN	1	V3186	Transformer 110V-12V

DRIVE CAP ASSEMBLY, DOWN FLOW PISTON, REGENERANT PISTON AND SPACER STACK ASSEMBLY

Item No.	Quantity	Part No.	Description
1	1	V3005	Spacer Stack Assembly
2	1	V3004	Drive Cap Assembly
3	1	V3135	O-Ring 228
4	1	V3011	Piston Assembly
5	1	V3180	O-Ring 337
6	1	V3105	O-Ring 2

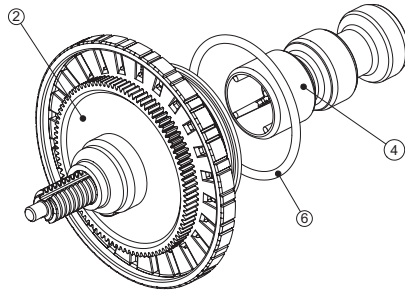
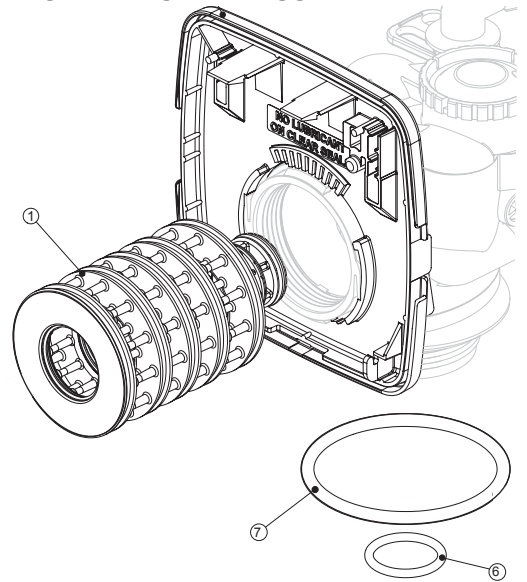

INJECTOR, INJECTOR CAP, SCREEN AND O-RING

Item No.	Quantity	Part No.	Description
1	1	V3176	Injector Cap
2	1	V3152	O-Ring 135
3	1	V3177	Injector Screen
4	1	V3010-1Z	Injector Assy. Z Plug
NOT SHOWN	*	V3170	O-Ring 011
NOT SHOWN	*	V3171	O-Ring 013

* Injector plug and injector contains one 011 and one 013 O-ring

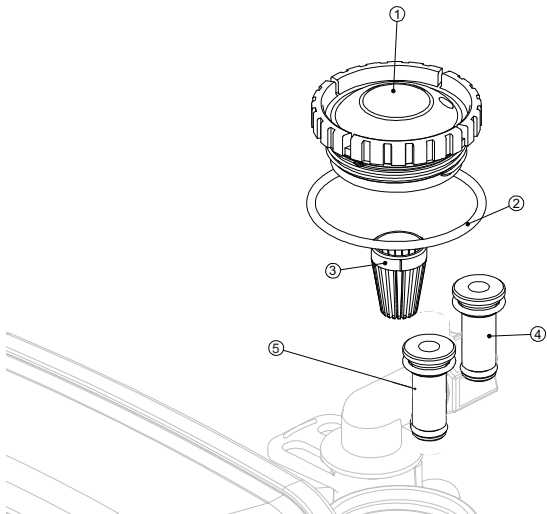

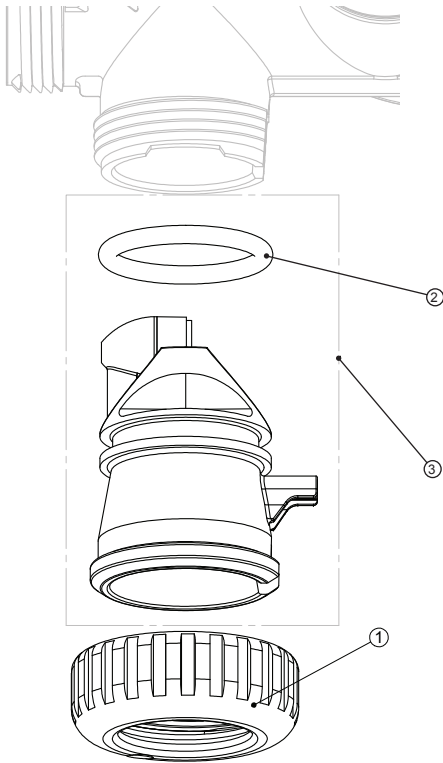

METER PLUG

Item No.	Quantity	Part No.	Description
1	1	V3151	Nut 1" QC
2	1	V3105	O-Ring 215
3	1	V3003	Meter Plug Assembly

DRAIN LINE - 3/4"

Item no.	Quantity	Part No.	Description
1	1	H4615	Elbow Locking Clip
2	1	V3194	Polytube Insert 5/8
3	1	V3192	Nut for 3/4 Drain Elbow
4	1	V3158	3/4 Drain Elbow
5	1	V3163	O-Ring 019
6	1	V3159	DLFC Retainer
7	1	V3162-056	DLFC 5.3
7	1	V3162-065	DLFC 6.5
7	1	V3162-090	DLFC 9.0
7	1	V3162-100	DLFC 10.0

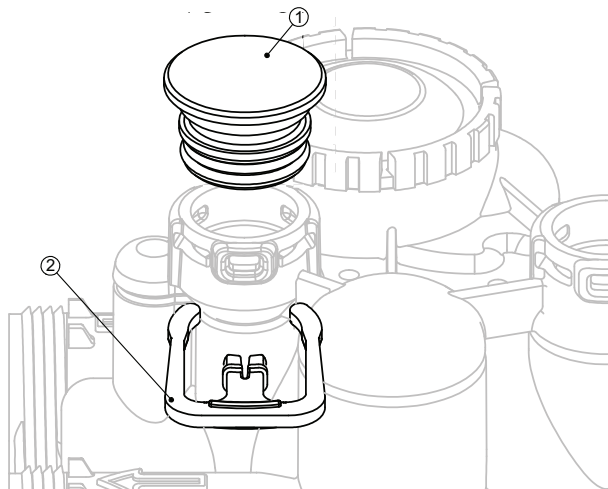
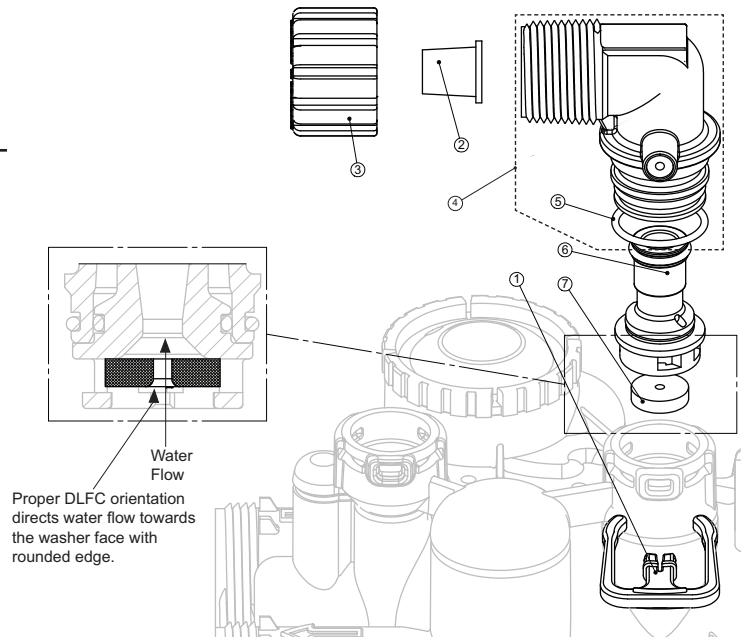

BRINE REFILL

Item No.	Quantity	Part No.	Description
1	1	H4615	Elbow Locking Clip
2	1	H4614	Polytube Insert 3/8"

TROUBLESHOOTING

PROBLEM	POSSIBLE CAUSE	SOLUTION
1. Timer does not display time of day.	<ul style="list-style-type: none"> a. Transformer unplugged b. No electric power at outlet c. Defective transformer d. Defective PC board 	<ul style="list-style-type: none"> a. Connect power b. Repair outlet or use working outlet c. Replace transformer d. Replace PC board
2. Timer does not display correct time of day.	<ul style="list-style-type: none"> a. Switched outlet b. Power outage c. Defective PC board 	<ul style="list-style-type: none"> a. Use uninterrupted outlet b. Reset time of day c. Replace PC board
3. Control valve regenerates at wrong time of day.	<ul style="list-style-type: none"> a. Power outages b. Time of day not set correctly c. Time of regeneration incorrect 	<ul style="list-style-type: none"> a. Reset control valve to correct time of day b. Reset to correct time of day c. Reset regeneration time
4. E1, E2 OR E3: Unable to recognize start of regeneration. Unexpected stall. Motor ran too long, timed out trying to reach next cycle position, or trying to reach home	<ul style="list-style-type: none"> a. Control valve has just been serviced b. Foreign matter is lodged in control valve c. High drive forces on piston d. Control valve piston not in home position e. Motor not inserted fully to engage pinion, motor wires broken or disconnected, motor failure f. Drive gear label dirty or damaged, missing or broken gear g. Drive bracket incorrectly aligned to back plate h. PC board is damaged or defective i. PC board incorrectly aligned to drive bracket 	<ul style="list-style-type: none"> a. Press SET HOUR and ▼ for 5 seconds or unplug power source jack (black wire) and plug back in to reset control valve. Reset time of day. b. Check piston and spacer stack assembly for foreign matter. c. Replace piston (s) and spacer stack assembly. d. Press SET HOUR and ▼ for 5 seconds or unplug power source jack (black wire) and plug back in to reset control valve. Reset time of day. e. Check motor and wiring. Replace motor if necessary. f. Replace or clean drive gear. g. Reset drive bracket properly. h. Replace PC board. i. Ensure PC board is correctly snapped onto drive bracket.
5. Control valve stalled in regeneration.	<ul style="list-style-type: none"> a. Motor not operating b. No electric power at outlet c. Defective transformer d. Defective PC board e. Broken drive gear or drive cap assembly f. Broken piston retainer g. Broken main or regenerant piston 	<ul style="list-style-type: none"> a. Replace motor b. Repair outlet or use working outlet c. Replace transformer d. Replace PC board e. Replace drive gear or drive cap assembly f. Replace drive cap assembly g. Replace main or regenerant piston
6. Control valve does not regenerate automatically when ▲ and ▼ buttons are depressed and held.	<ul style="list-style-type: none"> a. Transformer unplugged b. No electric power at outlet c. Broken drive gear or drive cap assembly d. Defective PC board 	<ul style="list-style-type: none"> a. Connect transformer b. Repair outlet or use working outlet c. Replace drive gear or drive cap assembly d. Replace PC board
7. Control valve does not regenerate automatically but does when ▲ and ▼ buttons are depressed.	<ul style="list-style-type: none"> a. Defective PC board b. Set-up error 	<ul style="list-style-type: none"> a. Replace PC board b. Check control valve set-up procedure