

INSTALLATION, OPERATION AND SERVICE MANUAL

MODEL 230-50D AIR INJECTOR



CAREFULLY READ THE LITERATURE PROVIDED BEFORE INSTALLATION!

The **LANCASTER** air injector is used in-line before filter systems to increase the percentage of dissolved oxygen content in the water system for effective oxidation.

PRE-INSTALLATION PREPARATION

THE PUMPING SYSTEM - The well pump must have the capacity necessary for proper air injector operation. The minimum well pump requirement is 5 GPM at 50 to 60 PSI before the air injector inlet. Submersible well pumps are recommended. Smaller jet pumps often do not develop the capacity and/or pressure needed for proper air injector operation. The air injector is a nozzle and venturi device that operates on the principle of differential pressure, i.e. the air injector creates a pressure drop in order to draw air into the water system. The well pump must be able to develop enough pressure to overcome all losses in the line up to and including the pressure drop across the air injector, and still be able to reach the cut-off pressure determined by the pressure switch setting. During the pumping cycle (well pump on to off) when the air injector draws air into the water system, an approximate 26 psi pressure drop across the air injector will occur within the 5GPM minimum to 20 GPM maximum air injector operating range.

NOTE: Even though the minimum well pump flow rate for proper air injector operation is 5 GPM, the well pump must be able to deliver no less than the backwash flow rate of the filter system installed! Most residential filter systems require 5 to 7 GPM backwash flow rate delivered by the well pump!

INSTALLATION

LOCATION - The air injector should be installed **BEFORE** the pressure tank (between the well pump and the pressure tank). A clean dry basement, pit or utility room to avoid temperature extremes are excellent choices.

PIPING - The air injector inlet/outlet size is 1" FPT. Allow at least 12" of straight pipe before the air injector inlet. Use only Teflon tape on male threads of pipe screwed into air injector. **DO NOT** use pipe joint compound on the PVC air injector inlet/outlet or plastic piping because it will damage (crack) plastic overtime.

DO NOT over-tighten piping into air injector inlet/outlet. Make sure air injector is installed in the correct direction; refer to flow arrows on the air injector body. A line strainer installed before the air injector to prevent particles from lodging in the nozzle is optional.

OPERATION

When the well pump is running, adjust the air injector's bypass valve so that it draws air into its air valve for at least the first one third of the well pump cycle.

SERVICE

The air injector body is machined from solid PVC bar stock, providing durability and corrosion resistance. All other parts are easily disassembled for cleaning.

SEE DRAWINGS ON REVERSE SIDE

TROUBLE SHOOTING

PROBLEM	POSSIBLE CAUSE(S)/SOLUTION
"Milky" or bubbly water from tap.	Excessive air injector air-draw. Reduce air-draw by adjusting air injector bypass valve. A LANCASTER AIR ELIMINATOR TANK, may be required to vent un-dissolved air from the water system.
Insufficient air-draw by the air injector.	Air injector's nozzle may be clogged. Remove and clean or replace. Air injector's air valve may be stuck. Remove and clean or replace. Check air injector bypass valve adjustment. If unable to adjust for long enough draw, check pumping rate.

MODEL 230-50D AIR INJECTOR ASSEMBLY

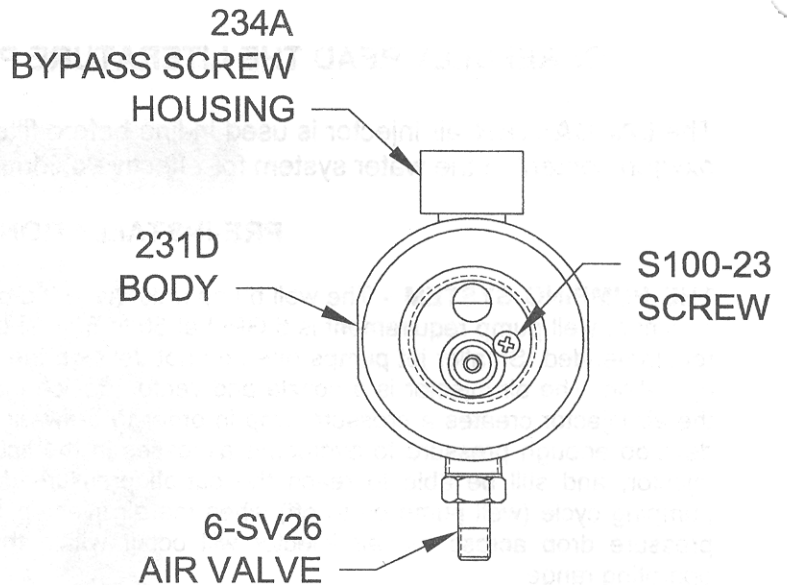
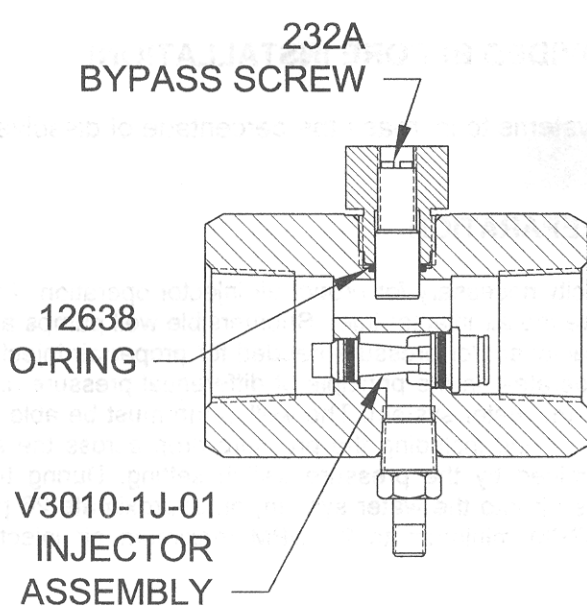

MODEL 230-50D AIR INJECTOR INSTALLATION

