



LANCASTER

WATER TREATMENT

X-FACTOR SERIES TTLX-NB NITRATE CONDITIONER

FRONT VIEW
SHOWN WITH BYPASS AND 1.0 MNPT ELBOWS

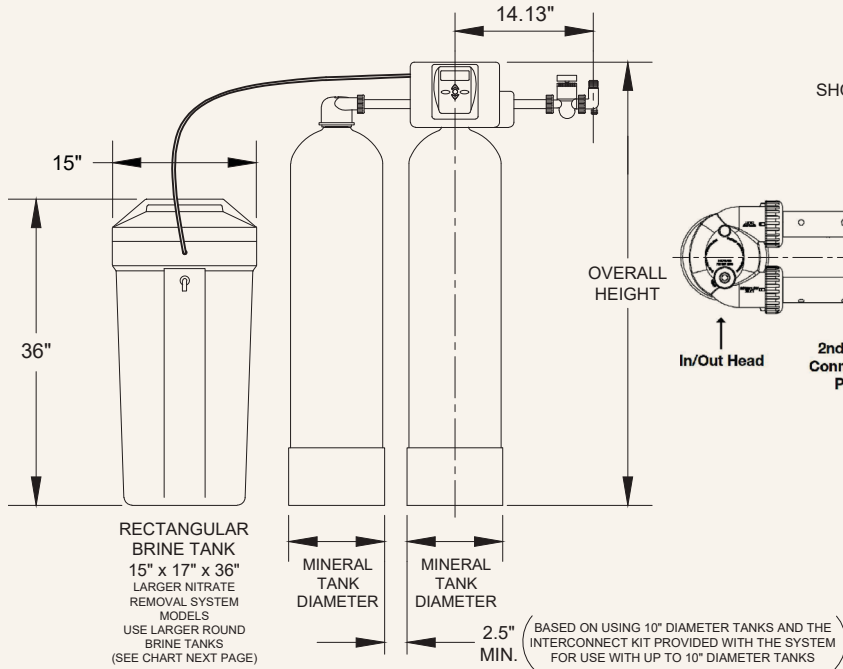

ENLARGED TOP VIEW
SHOWN WITH BYPASS AND 1.0 MNPT ELBOWS

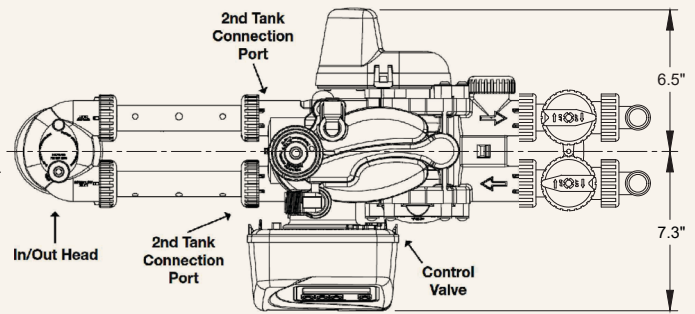

TTLX-NB PROGRAM CYCLES*

TWIN TANK NITRATE CONDITIONER

Model Number	7-TTLX-200NB		7-TTLX-300NB		7-TTLX-400NB		7-TTLX-600NB	
	Minutes	Gallons	Minutes	Gallons	Minutes	Gallons	Minutes	Gallons
Cycle 1: Fill - Treated Water into Brine Tank	6.67	3.33	10.00	5.00	13.33	6.67	20.00	10.00
Salt Setting - Salt Usage Per Regen (LBS NaCl)	10 LBS		15 LBS		20 LBS		30 LBS	
Cycle 2: Softening	60	0	60	0	60	0	60	0
Cycle 3: Backwash	10	10	10	10	10	13	10	22
Cycle 4: Regenerant Draw DN & Slow Rinse	50	18.5	50	18.5	50	26	50	36
Cycle 5: Backwash	10	10	10	10	10	13	10	22
Cycle 6: Rinse	5	5	5	5	5	6.5	5	11
Total Gallons to Drain**	46.8		48.5		65.2		101.0	
Total Regeneration Time (Minutes)	141.7		145.0		148.3		155.0	

*Downflow Regenerant, Prefill Factory Program Settings

**Based on 50 PSI Inlet Pressure

Note: These systems can be programmed using Pre-fill because the fully regenerated stand-by tank is brought online just before the tank requiring regeneration begins its regeneration cycles. The fully regenerated online tank provides treated water for the regenerating tank Fill Cycle 1.

Gallons to Drain = (Backwash Min. x DLFC GPM) + (Fast Rinse Min. x DLFC GPM) + (Regenerant Draw DN Min. x Slow Rinse GPM) + (LBS NaCl x 1 Gal./3 LBS NaCl)

Note: Slow Rinse GPM is obtained from injector charts for each color injector at various pressures.

X-FACTOR SERIES TTLX-NB NITRATE CONDITIONER

TTLX-NB SPECIFICATIONS	TWIN TANK NITRATE CONDITIONER			
Model Number	7-TTLX-200NB	7-TTLX-300NB	7-TTLX-400NB	7-TTLX-600NB
Inlet/Outlet Fitting Options (Inches) ¹	0.75 - 1.0 ¹ - 1.25 - 1.5	0.75 - 1.0 ¹ - 1.25 - 1.5	0.75 - 1.0 ¹ - 1.25 - 1.5	0.75 - 1.0 ¹ - 1.25 - 1.5
Built-In Meter Included	No	No	No	No
Bypass Included	Yes	Yes	Yes	Yes
Built-In Motorized Alternating Valve	Yes	Yes	Yes	Yes
Drain Fit. Elb. NPT or OD Poly Tube Size (Inches)	3/4 NPT or 5/8 Tube	3/4 NPT or 5/8 Tube	3/4 NPT or 5/8 Tube	3/4 NPT or 5/8 Tube
Water Pressure Range (PSI)	20 - 100	20 - 100	20 - 100	20 - 100
Water Operating Temperature Range (°F)	35 - 100	35 - 100	35 - 100	35 - 100
Influent Water Hardness (GPG)	≤ 4	≤ 4	≤ 4	≤ 4
Influent Iron (PPM)	< 0.3	< 0.3	< 0.3	< 0.3
Influent Manganese (PPM)	< 0.05	< 0.05	< 0.05	< 0.05
Plug-In Power Adapter Input (VAC - Hz - A)	120V AC - 60Hz - 0.35A	120V AC - 60Hz - 0.35A	120V AC - 60Hz - 0.35A	120V AC - 60Hz - 0.35A
Plug-In Power Adapter Output (VDC - A)	15V DC - 0.5A	15V DC - 0.5A	15V DC - 0.5A	15V DC - 0.5A
Plug-In Power Adapter Cord Length	15 FT	15 FT	15 FT	15 FT
PC Board Relay Terminal Block DC Output (V)	12V DC	12V DC	12V DC	12V DC
3 Volt Lithium Coin Cell Battery (Type)	CR2032	CR2032	CR2032	CR2032
Suggested Service Flow Rate Range (GPM) ²	1.00 - 3.74	1.50 - 5.61	2.00 - 7.48	3.00 - 11.22
Overall Height (Inches)	47.60	61.40	55.50	72.73
Mineral Tanks Size: Diameter x Height (Inches)	10 x 40	10 x 54	12 x 48	14 x 65
Bottom Distributor Type	Plate	Plate	Plate	Plate
Top Basket Distributor	Yes	Yes	Yes	Yes
Underbed Layer (Support Bedding)	No	No	No	No
Cubic Feet of Resin per Tank (LBS)	1.0 (44 LBS)	1.5 (66 LBS)	2.0 (88 LBS)	3.0 (132 LBS)
Brine Tank Size (Inches)	15 x 17 x 36 ³	15 x 17 x 36 ³ (Salt Grid)	15 x 17 x 36 ³ (Salt Grid)	18 D x 40 H (Salt Grid)
Brine Tank Capacity (LBS NaCl)	275	275	275	450
DLFC - Drain Line Flow Control (GPM) ⁴	1.0	1.0	1.3	2.2
RFC - Brine Line (Re-Fill) Flow Control (GPM)	0.5	0.5	0.5	0.5
Injector (Color)	IE - White	IE - White	IF - Blue	IH - Green
Grains Capacity per Tank (Grains @ LBS NaCl) ⁵	8,000 @ 10.0	12,000 @ 15.0	16,000 @ 20.0	24,500 @ 30.0
Water to Drain at 50 PSI Inlet Pressure (Gallons)	47	49	65	101

¹1.0 MNPT Elbow Standard - Options Available

²Service flow rates based on Jacobi Resinex NR-1 standard design conditions - service flow rate range 8 - 30 BV/h.

³See Diagram

⁴DLFC sizes selected based on Jacobi Resinex NR-1 standard design conditions - 50% backwash bed expansion at 4.5 m/h and 50°F.

⁵Grains Capacity is based on 8,241 grains per cubic foot as CaCO₃ operating capacity of Jacobi Resinex NR-1 for nitrate removal at 10 pounds of NaCl per cubic foot with an influent concentration of 600 mg/L TDS (sulfate concentration of 265 mg/L). Programming grains capacity must be in increments of 500 grains.