



CITYGUARD PRO

WATER FILTER INSTALLATION, OPERATING AND SERVICE MANUAL

ELECTRONIC WATER FILTER WITH THE X-FACTOR DIAMOND LINE CONTROL VALVE

7-LXMBCAT-1.5B

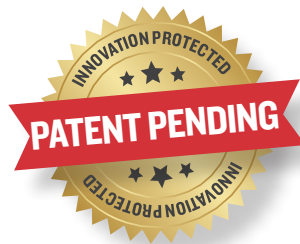

Congratulations on purchasing your new **Lancaster Water Filter**. This unit is designed to give you many years of trouble free service. For servicing and future inspection purposes, please file this booklet with your important documents.

In the event that you need assistance for servicing your water filter, please first contact the professional contractor who installed the system.

TABLE OF CONTENTS

Job Specifications	2
Pre-Installation Review	3
General Installation and Service Warnings	3
Bypass Valve Operation	4
General Installation Instructions	5
Installation and Start-Up	6,7
General Operation	8,9
User Displays	
Regeneration Mode	
Manual Regeneration	
Service Call Reminder	
Error Message	
Low Battery	
Set Time of Day	9
Adjust Days Between Backwash or Time of Backwash	10
Installer Contact Screen Programming	11
Parts Diagrams	12-19
Service Instructions	20-22
Troubleshooting	23-26

JOB SPECIFICATIONS

MODEL NO. _____

INSTALLATION DATE _____

SERIAL NUMBER _____

INSTALLER NAME _____ PHONE _____

ADDRESS _____

UNTREATED WATER TEST AT TIME OF INSTALLATION

_____ Hardness CaCo₃ (gpg) _____ pH Other: _____

_____ Chlorine (ppm or mg/l) _____ Chloramine (ppm or mg/l) _____

PRE-INSTALLATION REVIEW

WATER PRESSURE: A minimum of 20 psi water pressure is required for backwash. Maximum 100 psi. **CAUTION:** the filter cannot be subject to a vacuum due to loss of pressure (such as a water main break) as this may cause the filter tank to implode and could cause leakage. Provide a vacuum breaker in the installation if the possibility of a vacuum could occur.

WATER TEMPERATURE: The range of water temperature is 40°F to 100°F. DO NOT install any water filter with less than 10 feet of piping between its outlet and the inlet of a water heater. **CAUTION:** the use of a thermal expansion tank might be required to protect the filter in the event of a hot water heater backup. Refer to installation diagrams.

AMBIENT TEMPERATURE: DO NOT locate filter where it or its connections (including the drain line) will ever be subject to room temperatures under 33°F.

ELECTRICITY: An uninterrupted 120 volt 60Hz source is required. *Make sure electrical source is not on a timer or switch.* All electrical connections must be connected according to local codes. The plug-in power adapter is for dry locations only. Surge protection is recommended with all electrical connections.

Control Valve plug-in power adapter rating...

Input: 100-120 VAC, 50/60 Hz, 0.35 A

Output: 15 VDC, 0.5 A

DRAIN: All plumbing should be done in accordance with local plumbing codes. The distance between the drain and the water filter should be as short as possible. Avoid overhead drain lines if possible to prevent backpressure on the system. Refer to installation diagrams for drain line pipe size recommendation.

FILTERING: It is recommended that the filter be installed to treat both the hot and cold water supply. Outside faucets should be left on untreated water.

BYPASS: A bypass valve (included) should be installed so that water will be available if it should be necessary to shut off the pressure in order to service the filter.

GENERAL INSTALLATION AND SERVICE WARNINGS

The control valve, fitting assemblies and bypass valve are designed to accommodate minor plumbing misalignments but are not designed to support the weight of a system or the plumbing.

Do not use Vaseline, oils, other hydrocarbon lubricants or spray silicone anywhere. A silicone lubricant may be used on black o-rings but is not necessary. **Avoid any type of lubricants, including silicone, on the clear lip seals.**

The nuts and caps are designed to be unscrewed or tightened by hand or with the special plastic wrench (V3193). If necessary, pliers can be used to unscrew the nut or cap. Do not use a pipe wrench to tighten or loosen nuts or caps. Do not place a screw driver in the slots on caps and/or tap with a hammer.

Do not use pipe dope or other sealants on threads. Use Teflon tape on the threaded inlet, outlet and drain fittings. Teflon tape is not necessary on the nut connection or caps because of o-rings seals.

After completing any valve maintenance involving the drive assembly or the drive cap assembly and pistons, unplug power source jack from the printed circuit board (black wire) and plug back in or press and hold **NEXT** and **REGEN** buttons for 3 seconds. This resets the electronics and establishes the service piston position. The display should flash the software version and then reset the valve to the service position.

Solder joints near the drain must be done prior to connecting the drain line flow control fitting. Leave at least 6" between the drain line control fitting and solder joints when soldering pipes that are connected on the drain line control fitting. Failure to do this could cause interior damage to the drain line flow control fitting.

When assembling the installation fitting package (inlet and outlet), connect the fitting to the plumbing system first and then attach the nut, split ring and o-ring. Heat from soldering or solvent cements may damage the nut, split ring or o-ring. Solder joints should be cool and solvent cements should be set before installing the nut, split ring and o-ring. Avoid getting primer and solvent cement on any part of the o-ring, split rings, bypass valve or control valve.

If the building's plumbing is metal (e.g. copper) and the building's electrical system is grounded to the plumbing, install a copper grounding strap from the filter inlet pipe to the filter outlet pipe.

This water filter is not to be used for treating water that is microbiologically unsafe or of unknown quality without adequate disinfection before or after treatment.

BYPASS VALVE

The bypass valve is typically used to isolate the control valve from the plumbing system's water pressure in order to perform control valve repairs or maintenance. The X-Factor bypass valve is particularly unique in the water treatment industry due to its versatility and state of the art design features. The 1" full flow bypass valve incorporates four positions, including a diagnostic position that allows service personnel to work on a pressurized system while still providing untreated bypassed water to the facility or residence. Its completely non-metallic, all-plastic design allows for easy access and serviceability without the need for tools.

The bypass body and rotors are glass filled Noryl® (or equivalent) and the nuts and caps are glass filled polypropylene. All seals are self-lubricating EPDM to help prevent valve seizing after long periods of non-use. Internal o-rings can easily be replaced if service is required.

The bypass consists of two interchangeable plug valves that are operated independently by red arrow-shaped handles. The handles identify the flow direction of the water. The plug valves enable the bypass valve to operate in four positions.

OPERATION:

1. Normal Operation Position: The inlet and outlet handles point in the direction of flow indicated by the engraved arrows on the control valve. Water flows through the control valve during normal operation. During the regeneration cycle, this position also allows the control valve to provide regeneration water to the filter while also providing untreated water to the building plumbing system. (see figure 1)

2. Bypass Position: The inlet and outlet handles point to the center of the bypass. The control valve is isolated from the water pressure contained in the building plumbing system. Untreated water is supplied to the building plumbing system. (see figure 2)

3. Diagnostic Position: The inlet handle points in the direction of flow and the outlet handle points to the center of bypass valve. System water pressure is allowed to the control valve and the building plumbing system while not allowing water to exit from the control valve to the building plumbing. (see figure 3)

4. Shut Off Position: The inlet handle points to the center of the bypass valve and the outlet handle points in the direction of flow. The water is shut off to the building plumbing system. The filter will depressurize upon opening a tap in the building. If water is available on the outlet side of the filter it is an indication of water bypassing around the system (i.e. a plumbing connection somewhere in the building bypasses the system). (see figure 4)

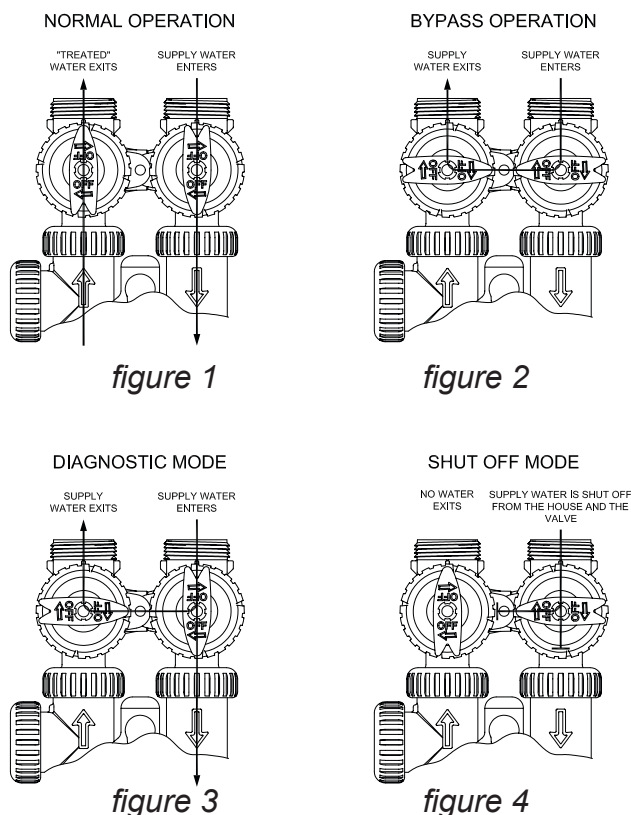

The working parts of the bypass valve are the rotor assemblies that are contained under the bypass valve caps. Before working on the rotors, make sure the system is depressurized. Turn the red arrow shaped handles towards the center of the bypass valve and back several times to ensure rotor is turning freely.

The nuts and caps are designed to be unscrewed or tightened by hand. If necessary a pliers or the service spanner wrench can be used to unscrew the nut or cap. Do not use a pipe wrench to tighten or loosen nuts or caps. Do not place screwdriver in slots on caps and/or tap with a hammer.

Refer to page 17 for bypass valve parts diagram and page 18 for service spanner wrench information.

To access the rotor, unscrew the cap and lift the cap, rotor and handle out as one unit. Twisting the unit as you pull it out will help to remove it more easily. There are three o-rings: one under the rotor cap, one on the rotor stem and the rotor seal. Replace worn o-rings. Clean rotor. Reinstall rotor.

When reinstalling the red arrow handles be sure that:

1. The handle pointers are lined up with the control valve body arrows, and the rotor seal o-ring and retainer on both rotors face to the right when being viewed from the front of the control valve; or
2. Arrows point toward each other in the bypass position.

Since the handles can be pulled off, they could be accidentally reinstalled 180° from their correct orientation. To install the red arrow handles correctly, keep the handles pointed in the same direction as the arrows engraved on the control valve body while tightening the bypass valve caps.

GENERAL INSTALLATION INSTRUCTIONS

(All electrical & plumbing should be done in accordance to all local codes)

1. Place filter in desired location close to the water supply inlet, and near a source for waste water, (utility sink, floor drain or sewer line). A 120V, 60Hz uninterrupted outlet is required. Keep filter far enough away from walls and other obstructions to allow enough room for servicing the unit.

Refer to specification sheet for filter dimensions.

2. CAUTION - SOAK MINERALS: Granular activated carbon is a low-density substance due to its highly porous structure, providing a vast internal surface area for adsorption. This light-weight filtration media **MUST BE SOAKED IN WATER FOR AT LEAST 12 HOURS PRIOR TO START UP.** Natural zeolite filtration media, located below the carbon, must also sit submerged in water for at least 12 hours. For **BEST RESULTS, 24 HOURS IS RECOMMENDED** to reduce the risk of media loss to drain during start up.

Remove the control valve from the mineral tank by turning the control valve counter-clockwise. Slowly remove the control valve, taking care not to allow the center distributor tube to rise upward. Water can be manually added at this time to begin the soaking process. Slowly pour water directly into the center distributor tube; continue this until the water level rises up to the tanks top dome (see diagram below). Replace the control valve **AFTER** the 12 to 24 hours soaking time has completed, making sure that the distributor tube is inserted into the bottom center hole (distributor pilot) of the control valve.

3. Do all necessary plumbing (inlet to inlet, outlet to outlet, and drain line to drain). The control valve, fittings assemblies and bypass valve are designed to accommodate minor plumbing misalignments but are not designed to support the weight of a system or the plumbing.

4. When assembling the installation fitting package (inlet and outlet), connect the fitting to the plumbing system first and then attach the nut, split ring and o-ring. Heat from soldering or solvent cements may damage the nut, split ring or o-ring. Solder joint should be cool and solvent cements should be set before installing the nut, split ring and o-ring. Avoid getting primer and solvent cement on any part of the o-rings, split rings, bypass valve or control valve.

5. A jumper ground wire should be installed between the inlet and outlet pipe whenever the metallic continuity of a water distribution piping system is interrupted. Install grounding strap on metal pipes.

6. The drain connection may be made using either a 3/4" or 1" female adapter (see below for recommended drain line size). If soldering, joints near the drain must be done prior to connecting the drain line flow control fitting. Leave at least 6" between the drain line control fitting and solder joints when soldering pipes that are connected on the drain line control fitting. Failure to do this could cause interior damage to the drain line flow control fitting. Never insert a drain line into a drain, sewer line, or trap. Always allow an air gap between the drain line and the wastewater to prevent the possibility of sewage being back-siphoned into the filter (fig. C). Refer to installation diagram on the next page. **CAUTION** - Attach drain line **SECURELY** to an air gap device on the waste line.

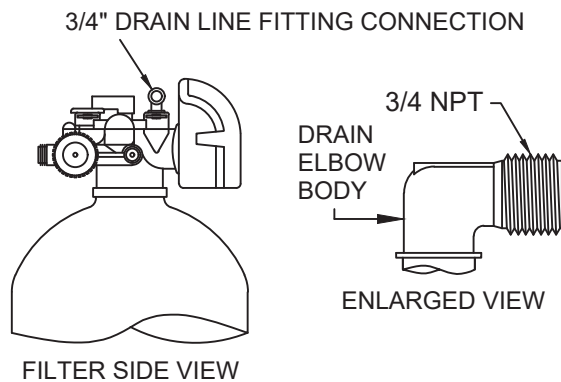
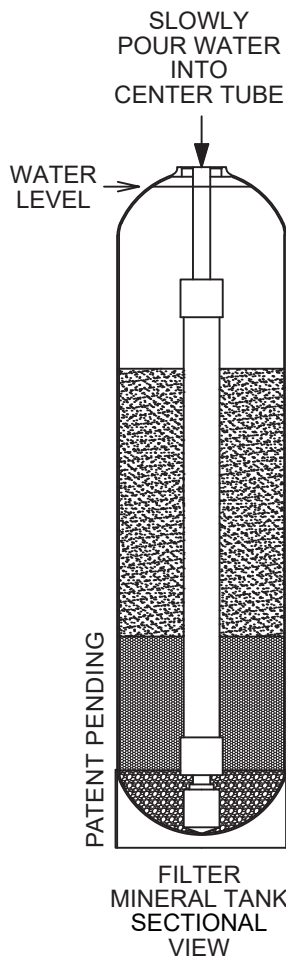

RECOMMENDED DRAIN LINE SIZE:

HARD PIPING A 3/4" DRAIN LINE IS RECOMMENDED FOR UP TO 10 GPM BACKWASH USING THE 3/4" NPT MALE THREADS ON THE DRAIN ELBOW BODY.

SEE NEXT PAGE FOR DRAIN LINE LIMITATIONS.

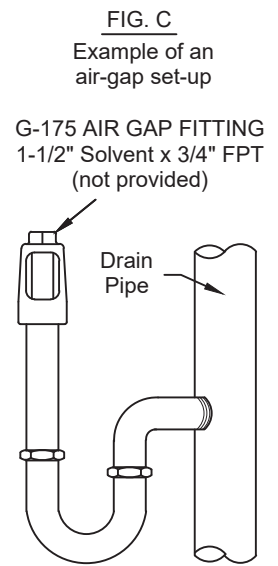

MODEL 7-LXMBCAT-1.5B INSTALLATION

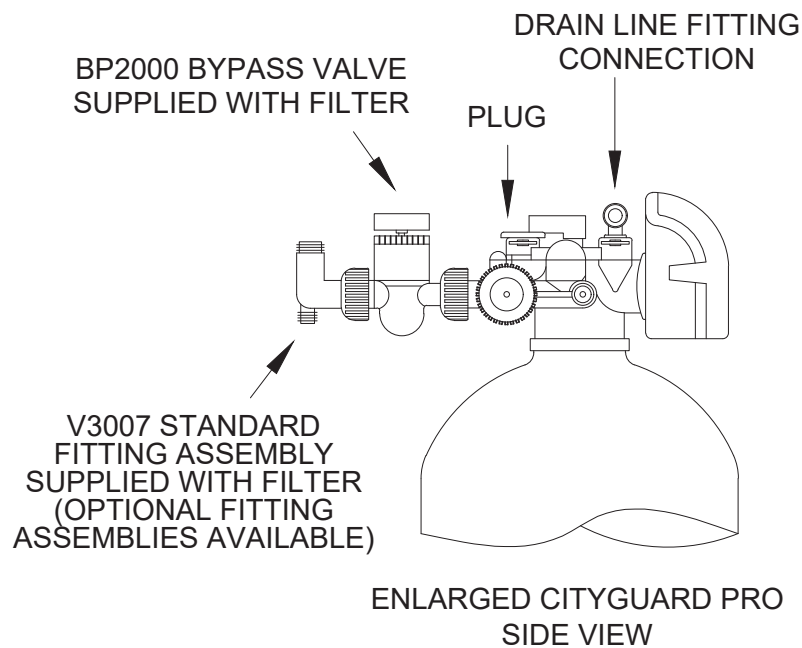
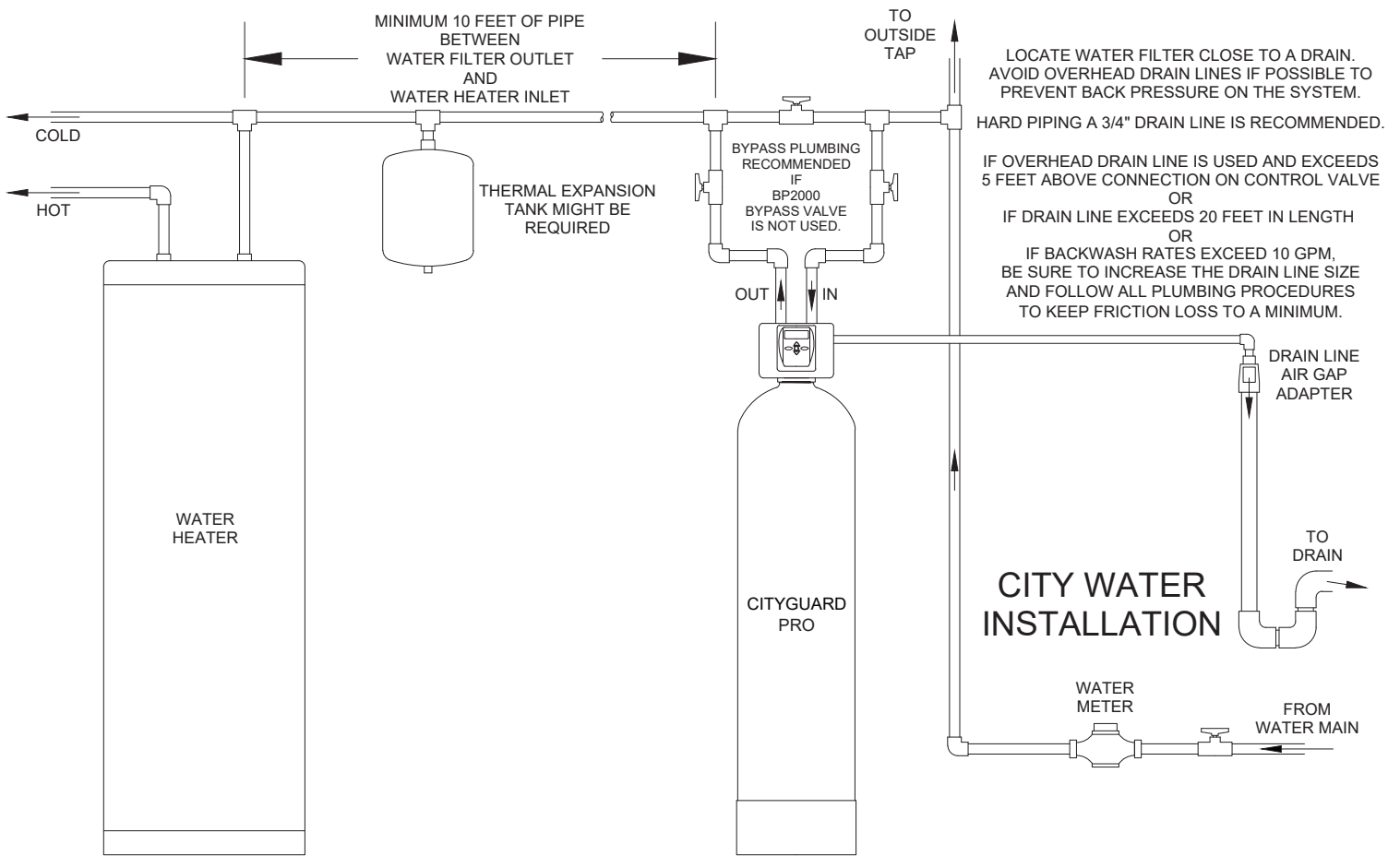

START-UP INSTRUCTIONS

CAUTION:

DO NOT perform the following start-up instructions unless the mineral soaking procedure has been completed as instructed on page 5, step 2. The mineral loaded in this filter **MUST SOAK IN WATER FOR AT LEAST 12 HOURS PRIOR TO START-UP** to minimize the risk of mineral loss to drain during the backwash cycle. For **BEST RESULTS, 24 HOURS IS RECOMMENDED.**

Do not plug the transformer into the receptacle yet. Rotate the bypass handles to the **BYPASS** position (see figure 2 on page 4). Turn on main water supply. Open a cold water faucet. This will clear the line of any debris that may be in the line. Let water run at faucet for a couple minutes, or until clear. Turn off faucet.

Only after the soaking procedure has been performed, plug the transformer into a 120 volt receptacle (be certain the receptacle is uninterrupted). Within 5 seconds the control display and buttons will illuminate and the time of day screen will appear.

- Press and hold the  button for approximately 5 seconds until the motor starts. The display will change color, from SOLID BLUE to SOLID GREEN.
- Wait until display reads **BACKWASH**, the motor stops running, and numbers start counting down. Unplug the transformer so the filter control valve will not cycle to the next position.

SLOWLY turn the bypass valve to the **DIAGNOSTIC** position (see figure 3 on page 4) to allow water to **SLOWLY** enter the filter in order to expel air.

CAUTION:

If the mineral has not been soaked as instructed, and if the water enters the filter too quickly, the mineral may plug the drain line and control valve. Flow water to drain very slowly, increasing the flow until the water runs clear. A very minimal amount of mineral may flow to drain during this procedure.

When water is flowing steadily to drain, clear and without the presence of air, plug the transformer into the receptacle to restore power. Momentarily press  again. Display will read **RINSE**. Place the bypass valve in the **NORMAL OPERATION MODE** (see figure 1 on page 4). Allow filter control valve to finish the **RINSE** cycle and automatically advance to the **FILTERING** position.

Continue to page 8 -11 for General Operation, User and Installer Display Settings.

GENERAL OPERATION

Note: As an energy saving feature, the control will automatically turn off all SOLID BLUE or SOLID GREEN display illumination and keypad illumination after about 5 minutes of the last keypad button push. Any further keypad touch will cause the re-illumination of the display and keypad, and re-activate keypad control.

User Displays

When the system is in normal service mode, display illumination is SOLID BLUE and one of up to four available User Displays will be shown. Pressing **NEXT** will alternate between the following displays:

- Current time of day
- Treated water flow rate
Utilizing the control valve's built-in water meter, a water drop flashes on the display when water is being treated (i.e. water is flowing through the system).
- Service contact name and phone number (if entered)
- Remaining days to regeneration (if Day Override is programmed)

If the system has called for a backwash that will occur at the preset time of backwash, the words REGEN TODAY will alternate with the header on the display.

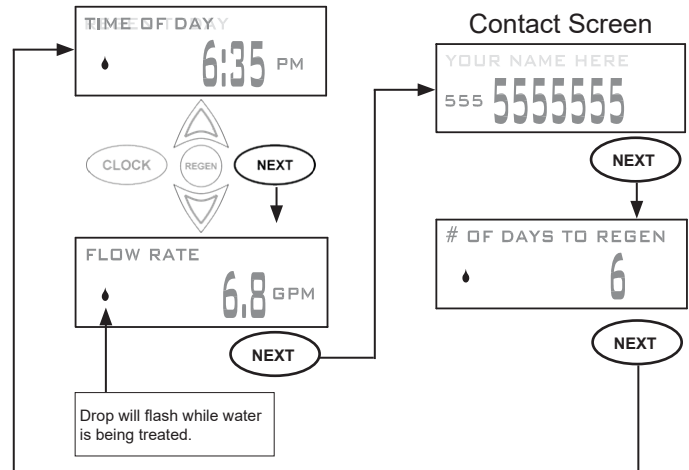

Regeneration Mode

Typically a system is set to regenerate at a time of low water usage. An example of a time with low water usage is when a household is asleep. If there is a demand for water when the system is regenerating, untreated water will be used. Factory preset delayed regeneration time: 12:00 AM (midnight).

When the system begins to regenerate, the display will change to SOLID GREEN when illuminated, and include information about the step of the regeneration process and the time remaining for that step to be completed. The current cycle display will alternate with the regen time remaining screen. The system runs through the steps automatically and will reset itself to provide treated water when the regeneration has been completed.

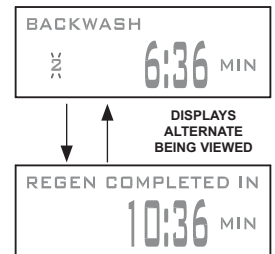

Manual Regeneration

Sometimes there is a need to regenerate the system sooner than when the system calls for it, usually referred to as manual regeneration. There may be a period of heavy water usage because of guests or a heavy laundry day.



To initiate a manual regeneration **at the preset delayed regeneration time**, press and release **REGEN**. The words "REGEN TODAY" will periodically be shown on the display to indicate that the system will regenerate at the preset delayed regeneration time. If you pressed the **REGEN** button in error, pressing the button again will cancel the request.

To initiate a manual regeneration **immediately**, press and hold the **REGEN** button for three seconds. The system will begin to regenerate immediately. The request cannot be cancelled.

Sometimes it is desirable to have the valve initiate and complete two regenerations within 24 hours and then return to the preset regeneration procedure. To do a double regeneration:

1. Press the **REGEN** button once. REGEN TODAY will flash on the display.
2. Press and hold the **REGEN** button for three seconds until the valve regeneration initiates.

Once the valve has completed the immediate regeneration, the valve will regenerate one more time at the preset regeneration time.

Service Call Reminder: An illuminated FLASHING YELLOW display and scrolling message to call contact name for scheduled service. To clear the Service Call Reminder, press  and  buttons simultaneously while the number banner text screen is displayed.

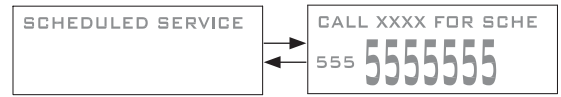

Error Message: If the valve is not able to function properly, the display will illuminate FLASHING RED, the word "ERROR" and an error code number will display. If a contact name and phone number were input, this information will alternate with the ERROR display, Contact the name on the display, the professional contractor or our factory for help.



Low Battery: A non-rechargeable 3 volt lithium coin cell battery type 2032 is located on the circuit board (see diagram on page 13, used only to maintain the time of day during power outages (all other information will be stored in memory no matter how long the power outage). The screen displays LOW BATTERY when the battery needs to be replaced. The screen will remain illuminated SOLID BLUE when LOW BATTERY is displayed. Initially LOW BATTERY display will alternate with the User display, finally displaying only LOW BATTERY. User displays are still accessible by pressing .

To replace with new battery, unplug the control valve transformer from the 120 volt receptacle first. Install new battery and then plug transformer back into the receptacle to restore power. **It is important to replace the battery with the control valve unplugged to prevent the possibility of causing a short and damaging the PC Board.**

SET TIME OF DAY

Current time of day needs to be entered during initial installation, and adjusted when daylight saving time begins or ends. If an extended power outage occurs and depletes the on-board non-rechargeable coin cell battery, when power resumes the time of day should be reset and battery replaced.

STEP 1



STEP 2



STEP 3







STEP 3





RETURN TO NORMAL MODE



STEP 1 – Press 

STEP 2 - Current Time (hour): Set the hour of the day using  or  buttons. AM/PM toggles after 12. Press  to go to Step 3.

STEP 3 - Current Time (minutes): Set the minutes of the day using  or  buttons. Press NEXT to exit Set Time of Day. Press  to return to previous step.

ADJUST DAYS BETWEEN BACKWASH, OR TIME OF BACKWASH

STEP 1

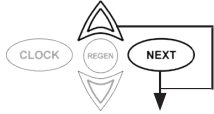

STEP 1 - Press **NEXT** and **REGEN** simultaneously for 3 seconds to access Installer Display Settings.

STEP 2

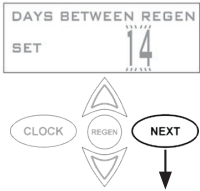

STEP 2 – Day Override: Set the maximum number of days between backwashes (REGEN). If value set to “OFF”, backwash initiation is based solely on volume used. If value is set as a number (allowable range from 1 to 28) a backwash initiation will be called for on that day even if sufficient volume of water were not used to call for a backwash. Set Day Override using **REGEN** or **DOWN** buttons:

- number of days between backwash (1 to 28); or
- “OFF”.

Press **NEXT** to go to step 3. Press **REGEN** to return to previous step.

STEP 3

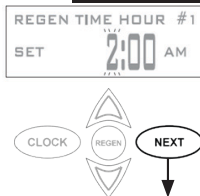

STEP 3 – Next Regeneration Time (hour): Set the hour of day for backwash using **REGEN** or **DOWN** buttons. AM/PM toggles after 12. The default time is 12:00 AM (midnight). Press **NEXT** to go to Step 4. Press **REGEN** to return to previous step.

STEP 4



STEP 4 – Next Regeneration Time (minutes): Set the minutes of day for backwash using **REGEN** or **DOWN** buttons. Press **NEXT** to return to normal operation. Press **REGEN** to return to previous step.

RETURN TO NORMAL MODE

INSTALLER CONTACT SCREEN PROGRAMMING

STEP 1

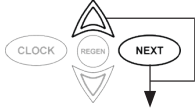

STEP 1 - Press **NEXT** and **REGEN** simultaneously for 3 seconds to access Installer Display Settings.

STEP 2



STEP 2 - Press **NEXT** to go to step 3.

STEP 3

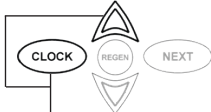

STEP 3 - While hour is flashing, press and hold both the **CLOCK** and **REGEN** button to change phone number and banner text.



Phone Number - Set phone number using the **REGEN** or **REGEN** arrow. Press **NEXT** to forward to the next digit. Press **REGEN** to return to previous digit.



Banner Text - Set the banner text up to a maximum of 44 characters. Use the **REGEN** or **REGEN** to select letters of the alphabet, numbers, ampersand (&), or a space in the banner text. Press **NEXT** to forward to the next character or to exit the Installer Display Settings.

CITYGUARD PRO 7-LXMBCAT-1.5B PARTS

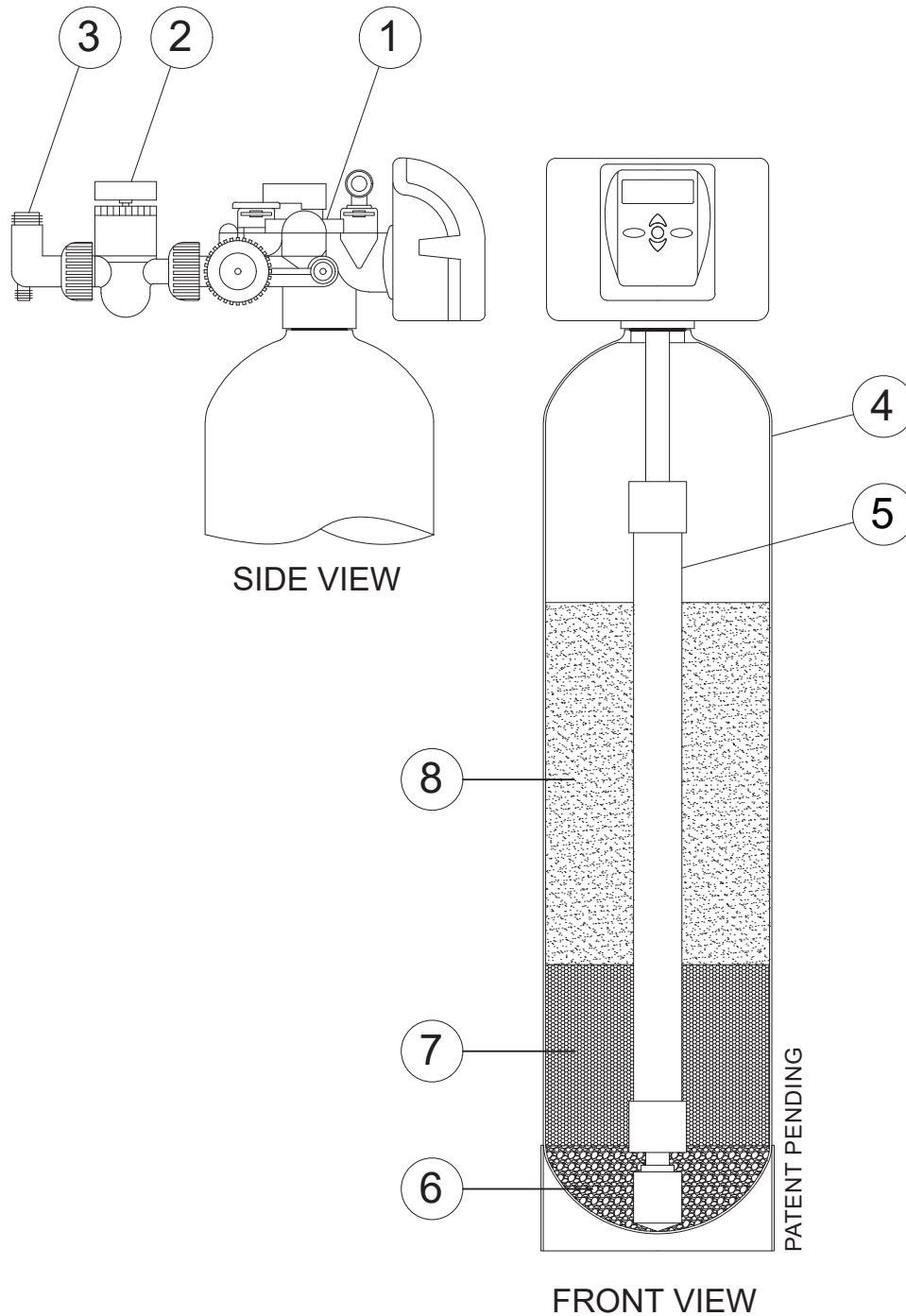

Dwg. No.	Order No.	Description	Qty.
1	LXCV1FM (detailed components shown in this manual)	Filter Metered Control Valve	1
2	BP2000 (detailed components shown in this manual)	Bypass Assembly	1
3	V3007 (detailed components shown in this manual)	Fitting Package - Two (2) 1" GFPP MNPT Elbow Assemblies	1
4	FG1054	Mineral Tank 10" DIA. x 54" HT.	1
5	DTAS-54	Trident Distributor Tube Assembly [Patent Pending] (Anti-Scale Media factory loaded inside)	1
6	A8072-15 (factory loaded)	Gravel Support Bed (15 LBS)	1
7	A8023 (factory loaded)	Natural Zeolite Media (25 LBS)	0.5 CU. FT.
8	LWG-CSH-SS (factory loaded)	Catalytic Carbon (28 LBS)	1 CU. FT.

X-FACTOR FRONT COVER AND DRIVE ASSEMBLY

Drawing No.	Order No.	Description	Quantity
1	V3692-02LW	LP Front Cover Assembly	1
2	V3107-01	Motor	1
3	V3106-01	Drive Bracket, Spring Clip, Drive Gear 12x36 and Drive Gear Cover	1
4	V3757LP	PC Board	1

When replacing the battery, align positives and push down to fully seat.

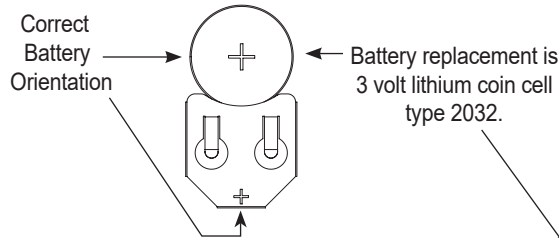
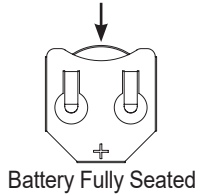

AC Adapter	(Not shown)
Order No.	V3186
Supply Voltage	120V AC
Supply Frequency	60 Hz
Input Current	0.35 A
Output Voltage	15V DC
Output Current	0.5 A

No user serviceable parts are on the PC board, the motor, or the power adapter. The means of disconnection from the main power supply is by unplugging the power adapter from the wall.

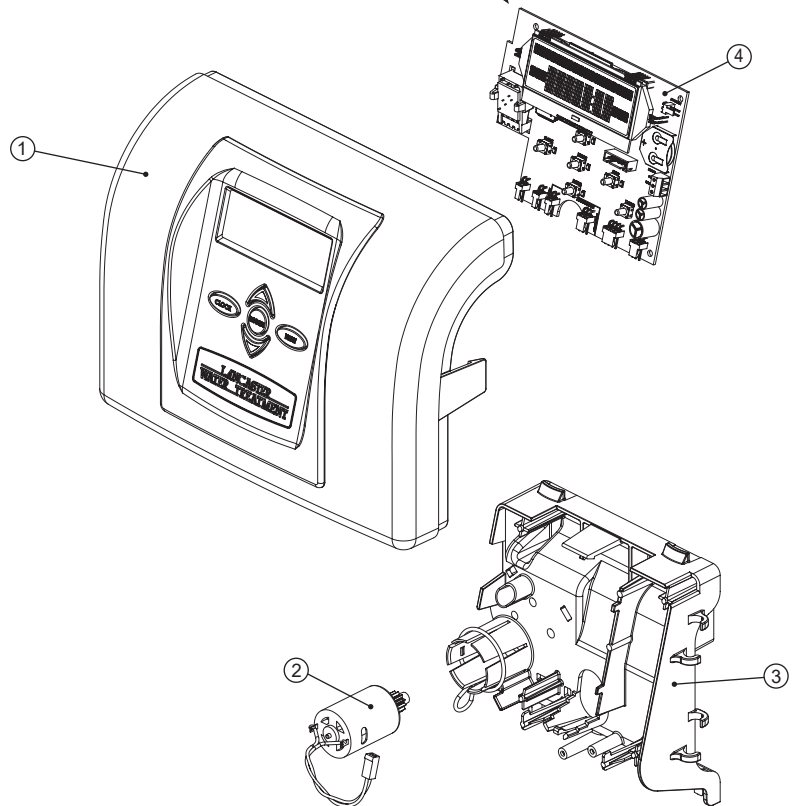

After completing any valve maintenance involving the drive assembly or the drive cap assembly and pistons, unplug power source jack from the printed circuit board (black wire) and plug back in or press and hold **NEXT** and **REGEN** buttons for 3 seconds. This resets the electronics and establishes the service piston position. The display should flash the software version and then reset the valve to the service position.

DRIVE CAP ASSEMBLY, DOWNFLOW PISTON, REGENERANT PISTON AND SPACER STACK ASSEMBLY

Drawing No.	Order No.	Description	Qty
1	V3005	Spacer Stack Assembly	1
2	V3004	Drive Cap Assy	1
3	V3178LP	Back Plate	1
4	V3011	Piston Downflow Assy	1
5*	V3174	Regenerant Piston	1
6	V3135	O-ring 228	1
7	V3180	O-ring 337 (Tank)	1
8	V3105	O-ring 215 (Distributor Tube)	1
Not Shown	V3001	Body Assy Downflow	1

Do not use Vaseline, oils, other hydrocarbon lubricants or spray silicone anywhere. A silicone lubricant may be used on black o-rings but is not necessary. **Avoid any type of lubricants, including silicone, on the clear lip seals.**

*Not used with CITYGUARD PRO Model 7-LXMBCAT-1.5B

After completing any valve maintenance involving the drive assembly or the drive cap assembly and pistons, unplug power source jack from the printed circuit board (black wire) and plug back in or press and hold **NEXT** and **REGEN** buttons for 3 seconds. This resets the electronics and establishes the service piston position. The display should flash the software version and then reset the valve to the service position.

Refer to pages 20-22 for detailed service instructions.

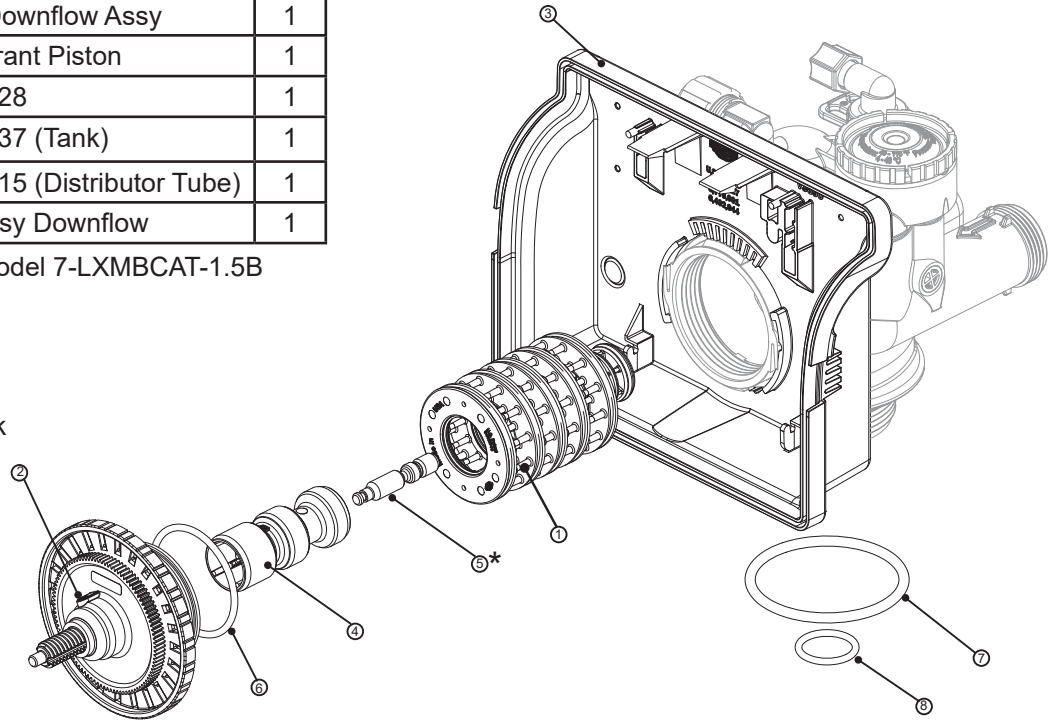

INJECTOR CAP, INJECTOR SCREEN, INJECTOR, PLUG AND O-RING

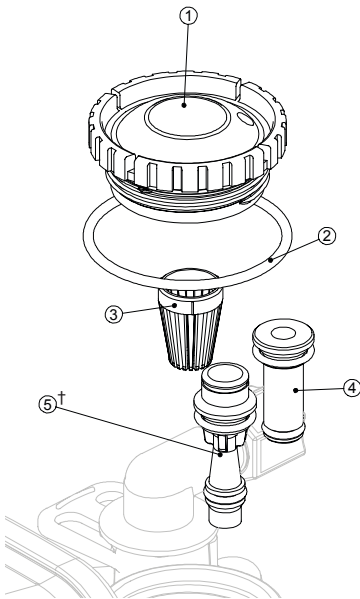

Drawing No.	Order No.	Description	Qty
1	V3176	Injector Cap	1
2	V3152	O-ring 135	1
3	V3177-01	Injector Screen Cage	1
4	V3010-1Z	Injector Assy Z Plug	1
5†	V3010-1C	Injector Assy C Violet (see chart below)	1
	V3010-1F	Injector Assy F Blue (see chart below)	
	V3010-1H	Injector Assy H Green (see chart below)	
Not Shown	V3170	O-ring 011	*
Not Shown	V3171	O-ring 013	*

* The injector plug and the injector each contain one 011 (lower) and 013 (upper) o-ring.

†Not used with CITYGUARD PRO Model 7-LXMBCAT-1.5B, a second V3010-1Z injector assy Z plug is used.

The nut and caps are designed to be unscrewed or tightened by hand or with the service spanner wrench (see page 18). If necessary a pliers can be used to unscrew the nut or cap. Do not use a pipe wrench to tighten or loosen nuts or caps. Do not place a screwdriver in slots on caps and/or tap with a hammer.

Refer to page 22 for detailed service instructions.

BRINE REFILL PLUG

Drawing No.	Order No.	Description	Qty
1	V3195	Refill Port Plug Assy	1
2	H4615	Elbow Locking Clip	1

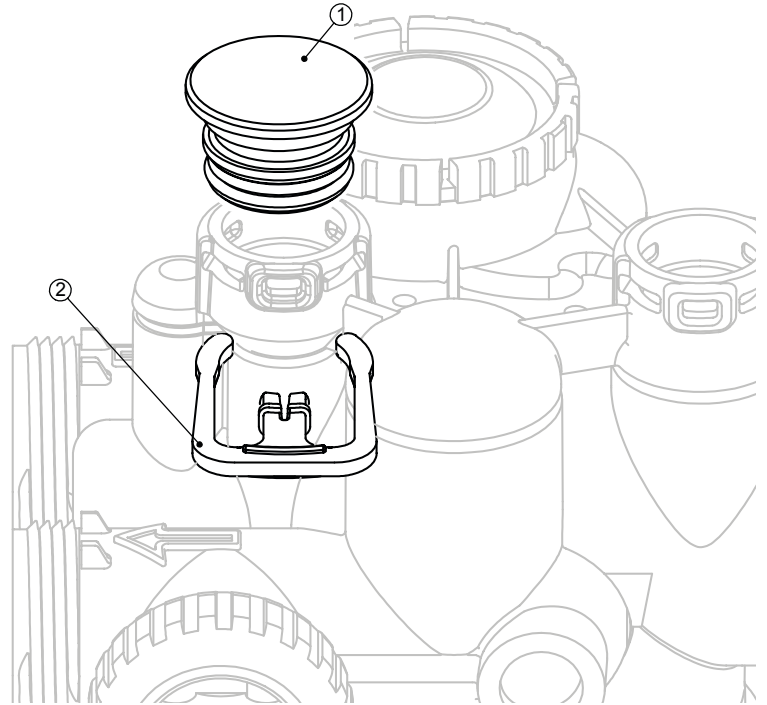

WATER METER

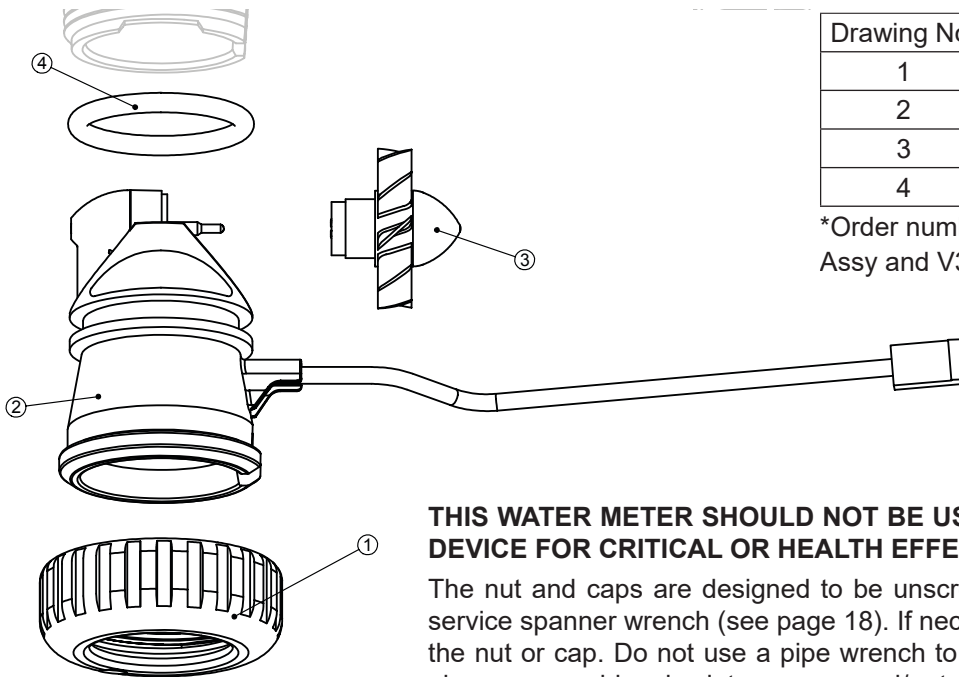

Drawing No.	Order No.	Description	Qty
1	V3151	Nut 1" QC	1
2	V3003*	Meter Assy	1
3	V3118-01	Turbine Assy	1
4	V3105	O-ring 215	1

*Order number V3003 includes V3118-01 Turbine Assy and V3105 O-ring 215.

THIS WATER METER SHOULD NOT BE USED AS THE PRIMARY MONITORING DEVICE FOR CRITICAL OR HEALTH EFFECT APPLICATIONS.

The nut and caps are designed to be unscrewed or tightened by hand or with the service spanner wrench (see page 18). If necessary a pliers can be used to unscrew the nut or cap. Do not use a pipe wrench to tighten or loosen nuts or caps. Do not place a screwdriver in slots on caps and/or tap with a hammer.

Refer to page 22 for detailed service instructions.

DRAIN LINE - 3/4"

Dwg No.	Order No.	Description	Qty
1	H4615	Elbow Locking Clip	1
2*	V3158	Drain Elbow 3/4 Male NPT, No Silencer	1
3	V3163	O-ring 019	1
4*	V3159	DLFC Retainer Assy	1
5	V3162-053	DLFC 5.3 gpm for 3/4	One DLFC must be used if 3/4 fitting is used

*2 and 4 can be ordered as a complete assembly - V3331 Drain Elbow and Retainer Assy

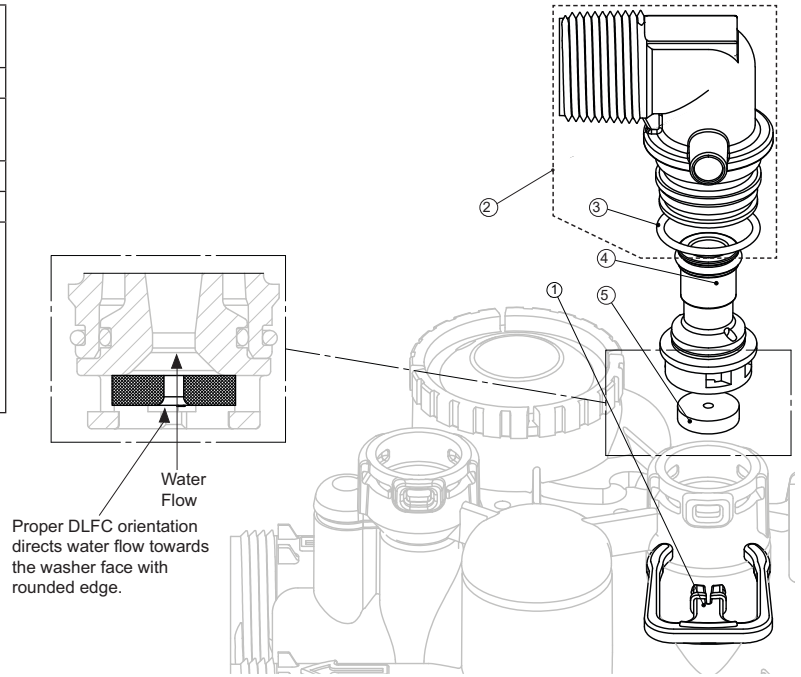

Do not use pipe dope or other sealants on threads. Teflon tape must be used on threads of 3/4" NPT connection.

Do not use Vaseline, oils, other hydrocarbon lubricants or spray silicone anywhere. A silicone lubricant may be used on black o-rings but is not necessary.

INSTALLATION FITTING ASSEMBLIES

Order No: **V3007** (Standard for all models)
Description: **Fitting 1" GFPP Male NPT Elbow Assembly**

Drawing No.	Order No.	Description	Quantity
1	V3151	Nut 1" Quick Connect	2
2	V3150	Split Ring	2
3	V3105	O-Ring 215	2
4	V3149	Fitting 1 PVC Male NPT Elbow	2

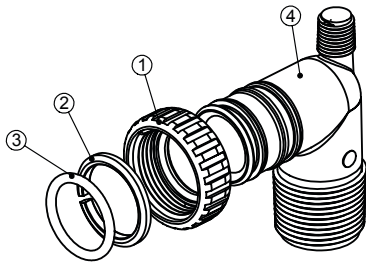

Order No. **V3191-01** (Optional)
Description: **Fitting Vertical Adapter Assembly**

Drawing No.	Order No.	Description	Quantity
1	V3151	Nut 1" Quick Connect	2
2	V3150	Split Ring	2
3	V3105	O-Ring 215	2
4	V3191	Vertical Adapter	2

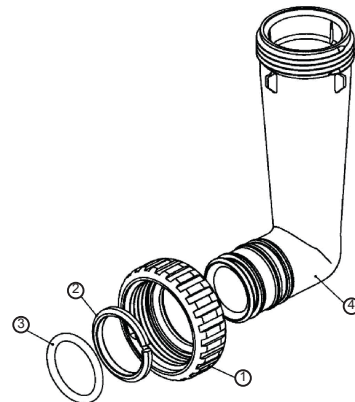

Do not use pipe dope or other sealants on threads. Teflon tape must be used on threads of 1" NPT connection. Teflon tape is not necessary on the nut connection nor caps because of o-ring seals.

The nut and caps are designed to be unscrewed or tightened by hand or with the service spanner wrench (see [page 18](#)). If necessary a pliers can be used to unscrew the nut or cap. Do not use a pipe wrench to tighten or loosen nuts or caps. Do not place a screwdriver in slots on caps and/or tap with a hammer.

Do not use Vaseline, oils, other hydrocarbon lubricants or spray silicone anywhere. A silicone lubricant may be used on black o-rings but is not necessary.

BYPASS VALVE

(Order No. BP2000)

Drawing No.	Order No.	Description	Qty
1	V3151	Nut 1" Quick Connect	2
2	V3150	Split Ring	2
3	V3105	O-Ring 215	2
4	V3145	Bypass 1" Rotor	2
5	V3146	Bypass Cap	2
6	V3147	Bypass Handle	2
7	V3148	Bypass Rotor Seal Retainer	2
8	V3152	O-ring 135	2
9	V3155	O-ring 112	2
10	V3156	O-ring 214	2

Refer to page 4 for detailed operation and service instructions.

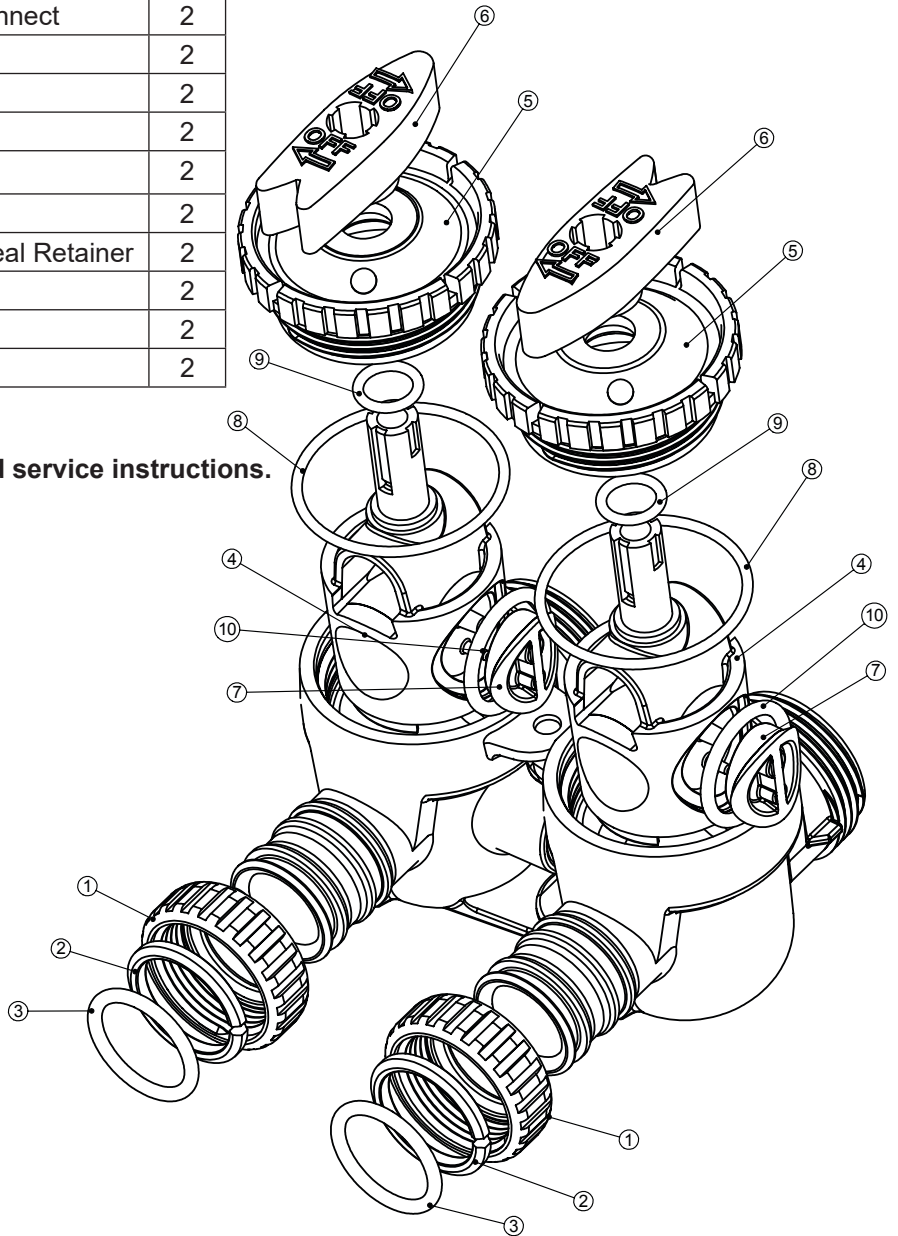

SERVICE SPANNER WRENCH

(Order No. V3193)

Although no tools are necessary to assemble or disassemble the valve, the wrench (shown in various positions on the valve) may be purchased to aid in assembly or disassembly.

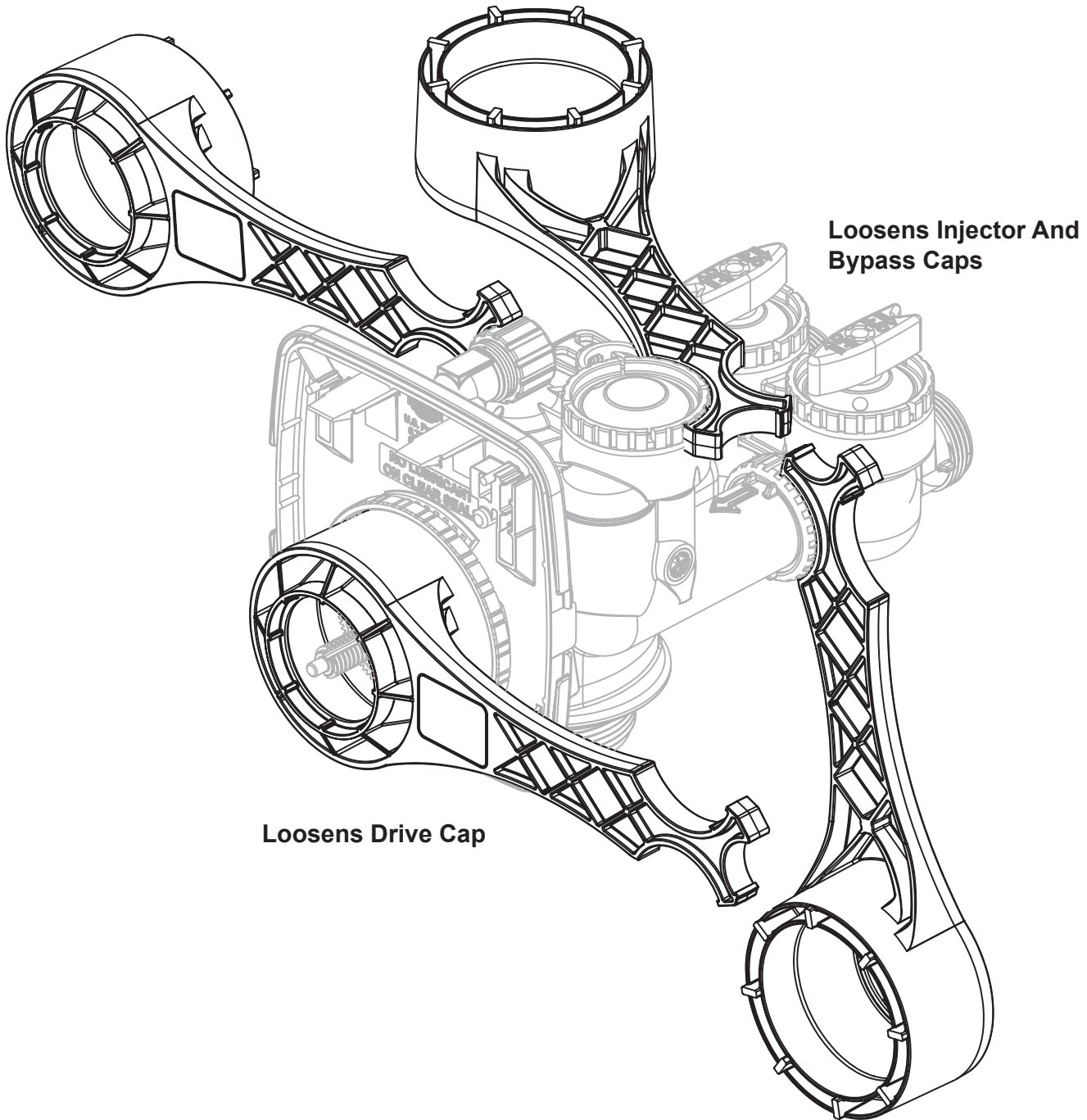

OPTIONAL INSTALLATION FITTING ASSEMBLIES

Order No: **V3007-01**
Description: **Fitting 3/4" & 1" PVC Solvent 90° Assembly**

Drawing No.	Order No.	Description	Quantity
1	V3151	Nut 1" Quick Connect	2
2	V3150	Split Ring	2
3	V3105	O-Ring 215	2
4	V3189	Fitting 3/4" & 1" PVC Solvent 90	2

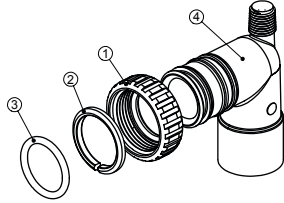

Order No: **V3007-02**
Description: **Fitting 1" Brass Sweat Assembly**

Drawing No.	Order No.	Description	Quantity
1	V3151	Nut 1" Quick Connect	2
2	V3150	Split Ring	2
3	V3105	O-Ring 215	2
4	V3188	Fitting 1" Brass Sweat Assembly	2

Do not install in California.

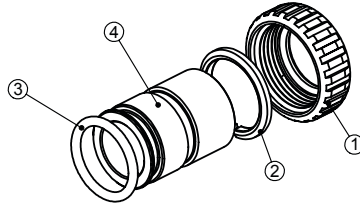

Order No: **V3007-03**
Description: **Fitting 3/4" Brass Sweat Assembly**

Drawing No.	Order No.	Description	Quantity
1	V3151	Nut 1" Quick Connect	2
2	V3150	Split Ring	2
3	V3105	O-Ring 215	2
4	V3188-01	Fitting 3/4" Brass Sweat	2

Do not install in California.

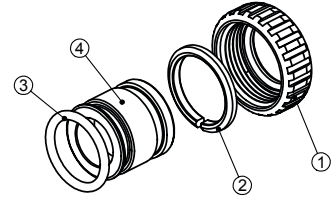

Order No: **V3007-04**
Description: **Fitting 1" Plastic Male NPT Assembly**

Drawing No.	Order No.	Description	Quantity
1	V3151	Nut 1" Quick Connect	2
2	V3150	Split Ring	2
3	V3105	O-Ring 215	2
4	V3164	Fitting 1" Plastic Male NPT	2

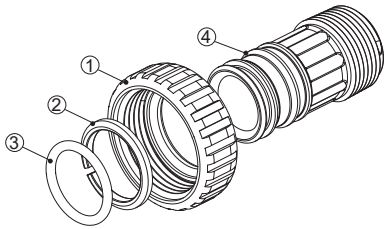

Order No: **V3007-05**
Description: **Fitting 1-1/4" Plastic Male NPT Assembly**

Drawing No.	Order No.	Description	Quantity
1	V3151	Nut 1" Quick Connect	2
2	V3150	Split Ring	2
3	V3105	O-Ring 215	2
4	V3317	Fitting 1-1/4" Plastic Male NPT	2

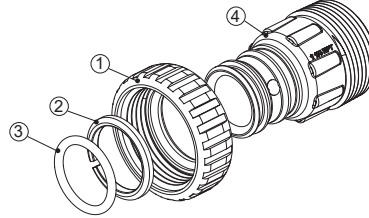

Order No: **V3007-07**
Description: **Fitting 1/4" & 1/2" PVC Solvent Assembly**

Drawing No.	Order No.	Description	Quantity
1	V3151	Nut 1" Quick Connect	2
2	V3150	Split Ring	2
3	V3105	O-Ring 215	2
4	V3352	Fitting 1/4" & 1/2" PVC Solvent	2

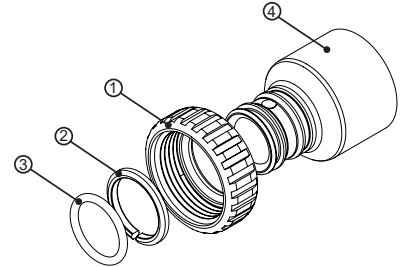

Order No: **V3007-09**
Description: **Fitting 1 1/4" & 1 1/2" Brass Sweat Assembly**

Drawing No.	Order No.	Description	Quantity
1	V3151	Nut 1" Quick Connect	2
2	V3150	Split Ring	2
3	V3105	O-Ring 215	2
4	V3375	Fitting 1 1/4" & 1 1/2" Brass Sweat	2

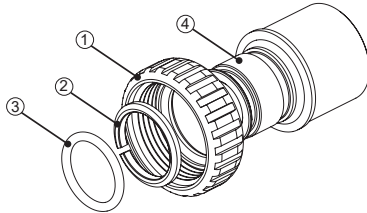

Order No: **V3007-12**
Description: **Fitting 3/4" Brass SharkBite Assembly**

Drawing No.	Order No.	Description	Quantity
1	V3151	Nut 1" Quick Connect	2
2	V3150	Split Ring	2
3	V3105	O-Ring 215	2
4	V3628	Ftg 3/4" Brass Shark-Bite	2

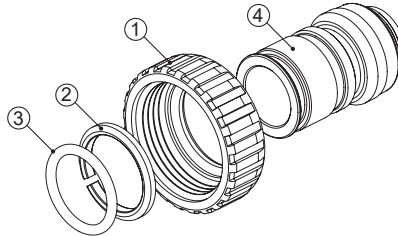

Order No: **V3007-13**
Description: **Fitting 1" Brass SharkBite Assembly**

Drawing No.	Order No.	Description	Quantity
1	V3151	Nut 1" Quick Connect	2
2	V3150	Split Ring	2
3	V3105	O-Ring 215	2
4	V3629	Ftg 1" Brass Shark-Bite	2

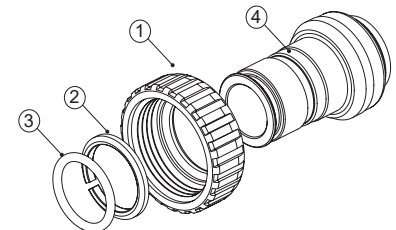

Order No: **V3007-15**
Description: **WS1 FTG 3/4 JG QC 90 ASY**

Drawing No.	Order No.	Description	Quantity
1	V3151	WS1 NUT 1 QC	2
2	V3150	WS1 SPLIT RING	2
3	V3105	O-RING 215	2
4	V3790	WS1 ELBOW 3/4 QC W/STEM	2

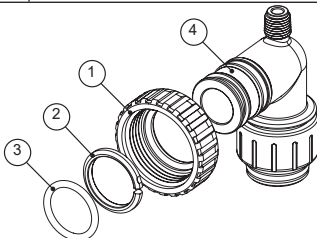

Order No: **V3007-17**
Description: **WS1 FTG 1" JG QC ASY**

Drawing No.	Order No.	Description	Quantity
1	V3105	O-RING 215	2
2	V3150	WS1 SPLIT RING	2
3	V3151	WS1 NUT 1 QC	2
4	V4045	WS1 FTG 1 INCH QC	2

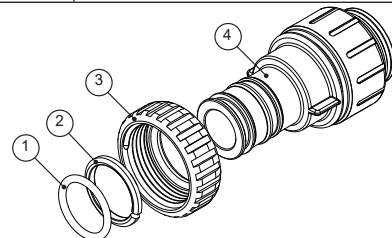

CONTROL VALVE SERVICE INSTRUCTIONS



CAUTION: Never perform service on an installed filter control valve unless pressure is fully relieved from the filter system. Injury and/or flooding can occur.



When servicing the valve, water may leak from the valve. Water from the valve may create a slip hazard. Clean up water spills.



Disconnect from electrical power prior to servicing the valve.

DRIVE ASSEMBLY (refer to pages 13 & 14 for diagrams):

Remove the valve cover to access the drive assembly.

Disconnect the power source plug (black wire) from the PC board prior to disconnecting the motor or water meter plugs from the PC board. The power source plug connects to the four-pin jack. The motor plug connects to the two-pin jack on the left-hand side of the PC board. The water meter plug (gray wire) connects to the three-pin jack on the far right-hand side of the PC board.

The PC board can be removed separately from the drive bracket but it is not recommended. Do not attempt to remove the display panel from the PC board. Handle the board by the edges. To remove the PC board from the drive bracket, unplug the power, water meter and motor plugs from the PC board. Lift the middle latch along the top of the drive bracket while pulling outward on the top of the PC board. The drive bracket has two plastic pins that fit into the holes on the lower edge of the PC board. Once the PC board is tilted about 45° from the drive bracket it can be lifted off of these pins. To reinstall the PC board, position the lower edge of the PC board so that the holes in the PC board line up with the plastic pins. Push the top of the PC board towards the valve until it snaps under the middle latch, weave the power and water meter wires into the holders and reconnect the motor, water meter and power plugs.

The drive bracket must be removed to access the drive cap assembly and pistons or the drive gear cover. It is not necessary to remove the PC board from the drive bracket to remove the drive bracket. To remove the drive bracket start by removing the plugs for the power source and the water meter. Unweave the wires from the side holders. Two tabs on the top of the drive back plate hold the drive bracket in place. Simultaneously lift the two tabs and gently ease the top of the drive bracket forward. The lower edge of the drive bracket has two notches that rest on the drive back plate. Lift up and outward on the drive bracket to disengage the notches.

To reassemble, seat the bottom of the drive bracket so the notches are engaged at the bottom of the drive back plate. Push the top of the drive bracket toward the two latches. The drive bracket may have to be lifted slightly to let the threaded piston rod pass through the hole in the drive bracket. Maintain a slight engaging force on top of the drive bracket while deflecting the bracket slightly to the left by pressing on the side of the upper right corner. This helps the drive gears mesh with the drive cap assembly. The drive bracket is properly seated when it snaps under the latches on the drive back plate. If resistance is felt before latching, then notches are not fully engaged, the piston rod is not in hole, the wires are jammed between the drive bracket and drive back plate, or the gear is not engaging the drive cap assembly.

To inspect the drive gears, the drive gear cover needs to be removed. Before trying to remove the gear cover, the drive bracket must be removed from the drive back plate. (Refer to the instructions above regarding removing the drive bracket from the drive back plate. The drive gear cover can be removed from the drive bracket without removing the motor or the PC board.) The drive gear cover is held in place on the drive bracket by three clips. The largest of the three clips is always orientated to the bottom of the drive bracket. With the PC board facing up, push in and down on the large clip on the drive gear cover. Handle the cover and the gears carefully so that the gears do not fall off the pegs in the cover.

Replace broken or damaged drive gears. Do not lubricate any of the gears. Avoid getting any foreign matter on the reflective coating because dirt or oils may interfere with pulse counting.

The drive gear cover only fits on one way, with the large clip orientated towards the bottom. If all three clips are outside of the gear shroud on the drive bracket the drive gear cover slips easily into place.

The drive bracket does not need to be removed from the drive plate if the motor needs to be removed. To remove the motor, disconnect the power and motor plugs from the jacks on the PC board. Move the spring clip loop to the right and hold. Rotate the motor at least a ¼ turn in either direction so the wires are vertical (up & down) before gently pulling on the wire connectors to remove the motor. Pulling directly on the wires without rotating the motor may break the wires off the motor.

Replace the motor if necessary. Do not lubricate the motor or the gears. To reinstall the motor, move the spring clip loop to the right and hold. Gently turn the motor while inserting so that the gear on the motor meshes with the gears under the drive gear cover. Release the spring clip loop and continue to rotate the motor until the wires are horizontal and the motor housing engages the small plastic bulge inside the drive bracket motor retainer. Reconnect the motor plug to the two-pronged jack on the lower left side of the PC board. If the motor will not easily engage with the drive gears when reinstalling, lift and slightly rotate the motor before reinserting. Reconnect the power plug.

Replace the valve cover. After completing any valve maintenance involving the drive assembly or the drive cap assembly and pistons, unplug power source jack from the printed circuit board (black wire) and plug back in or press and hold **NEXT** and **REGEN** buttons for 3 seconds.

This resets the electronics and establishes the service piston position. The display should flash the software version and then reset the valve to the service position.

DRIVE CAP ASSEMBLY, MAIN PISTON AND REGENERANT PISTON (refer to page 13 & 14 for diagrams):

The drive assembly must be removed to access the drive cap assembly. The drive cap assembly must be removed to access the piston(s). The drive cap assembly is threaded into the control valve body and seals with an o-ring. To remove the drive cap assembly use the special plastic service spanner wrench (see page 18) or insert a ¼" to ½" flat blade screwdriver into one of the slots around the top 2" of the drive cap assembly so it engages the notches molded into the drive back plate around the top 2" of the piston cavity. See figure below. The notches are visible through the holes. Lever the screwdriver so the drive cap assembly turns counter clockwise. Once loosened unscrew the drive cap assembly by hand and pull straight out.

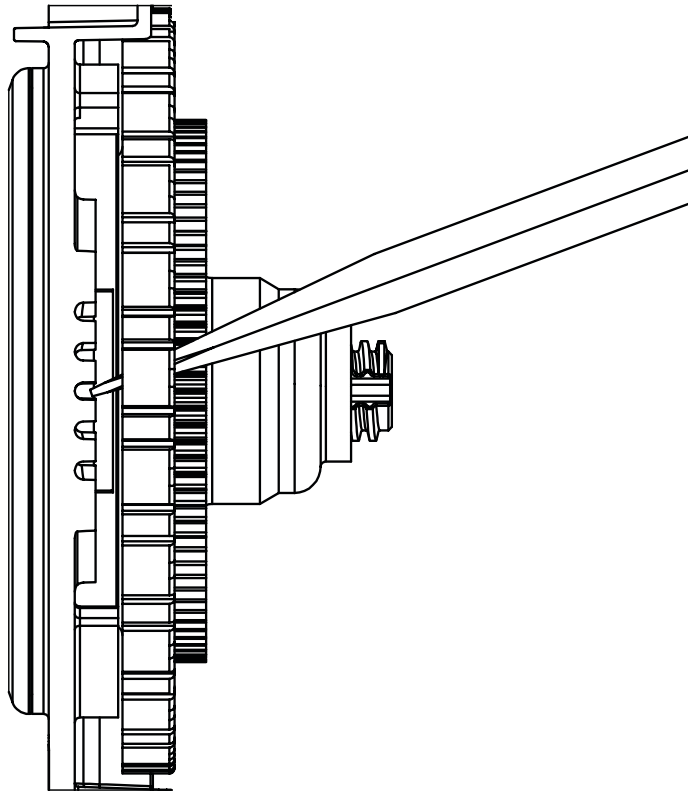

The drive cap assembly contains the drive cap, the main drive gear, drive cap spline, piston rod and various other parts that should not be disassembled in the field. The only replaceable part on the drive cap assembly is the o-ring. Attached to the drive cap assembly is the main piston.

To remove the main piston fully extend the piston rod and then unsnap the main piston from its latch by pressing on the side with the number. Chemically clean in dilute sodium bisulfite or vinegar, or replace the main piston.

Reattach the main piston to the drive cap assembly. Reinsert the drive cap assembly and piston into the spacer stack assembly and hand tighten the drive cap assembly. Continue to tighten the drive cap assembly using a screwdriver as a ratchet until the black o-ring on the spacer stack assembly is no longer visible through the drain port. Excessive force can break the notches molded into the drive back plate. Make certain that the main drive gear still turns freely. The exact position of the piston is not important as long as the main drive gear turns freely.

Reattach the drive assembly to the control valve and connect all plugs. After completing any valve maintenance involving the drive assembly or the drive cap assembly and pistons, unplug power source jack from the printed circuit board (black wire) and plug back in or press and hold **NEXT** and **REGEN** buttons for 3 seconds.

This resets the electronics and establishes the service piston position. The display should flash the software version and then reset the valve to the service position.



SPACER STACK ASSEMBLY (refer to page 13 & 14 for diagrams):

To access the spacer stack assembly remove the drive assembly, drive cap assembly and piston. The spacer stack assembly can be removed easily without tools by using thumb and forefinger. Inspect the black o-rings and clear lip seals for wear or damage. Replace the entire stack if necessary. Do not disassemble the stack.

The spacer stack assembly may be chemically cleaned (dilute sodium bisulfite or vinegar) or wiped with a soft cloth.

The spacer stack assembly can be pushed into the control valve body bore by hand. Since the spacer stack assembly can be compressed it is easier to use a blunt object (5/8" to 1-1/8" in diameter) to push the center of the assembly into the control valve body. The assembly is properly seated when at least four threads are exposed (approximately 5/8"). Do not force the spacer stack assembly in. The control valve body bore interior can be lubricated with silicone to allow for easy insertion of the entire stack.

Reattach the drive cap assembly and piston(s) and the drive assembly.

After completing any valve maintenance involving the drive assembly or the drive cap assembly and pistons, unplug power source jack from the printed circuit board (black wire) and plug back in or press and hold  and  buttons for 3 seconds.

This resets the electronics and establishes the service piston position. The display should flash the software version and then reset the valve to the service position.

INJECTOR CAP, SCREEN, INJECTOR PLUG, AND INJECTOR (refer to page 14 for diagram):

Unscrew the injector cap and lift off. Loosen cap with special plastic service spanner wrench (see page 18) or pliers if necessary. Attached to the injector cap is a screen. Remove the screen and clean if fouled.

CITYGUARD PRO Model 7-LXMBCAT-1.5B does not use an injector.

The two plugs can be pried out with a small screwdriver. The plugs can be wiped clean. If the plugs leak replace the entire plugs.

Push the plugs in the holes marked "UP" and "DN".

Replace the screen and hand tighten the injector cap.

WATER METER (refer to page 15 for diagrams):

The water meter assembly is connected to the PC board by a wire. If the entire water meter assembly is to be replaced, remove the control valve cover and disconnect the power source and water meter plugs from the PC board. Unlatch the drive assembly and lean it forward. Unthread the water meter wire from the side of the drive assembly and through the drive back plate. To reinstall, rethread the water meter wire through the drive back plate and the side of the drive assembly. Reattach the drive assembly and the water meter and power plugs.

THIS WATER METER SHOULD NOT BE USED AS THE PRIMARY MONITORING DEVICE FOR CRITICAL OR HEALTH EFFECT APPLICATIONS.

The water meter wire does not need to be removed from the PC board if the water meter is only being inspected and cleaned. To remove the water meter assembly, unscrew the meter cap on the left side of the control valve. Pliers may be used to unscrew the nut if necessary.

With the nut removed, a slot at the top of the water meter is visible. Twist a flat blade screwdriver in the slot between the control valve body and the meter. When the meter is part way out it is easy to remove the water meter from the housing. Once the water meter is removed from the control valve body, gently pull forward on the turbine to remove it from the shaft.

Do not use a wire brush to clean the turbine. Wipe with a clean cloth or chemically clean in dilute sodium bisulfite or vinegar. The turbine can be immersed in the chemical. Do not immerse electronics. If the turbine is scored or damaged or the bearings on the turbine are worn, replace the turbine.

Do not lubricate the turbine shaft. The turbine shaft bearings are prelubricated. Do not use Vaseline, oils, or other unacceptable lubricants on the o-ring. A silicone lubricant may be used on the black o-ring.

Snap the turbine on the shaft and reinsert the water meter into the side slot. Hand tighten the nut. Do not use a pipe wrench to tighten nut.

TROUBLESHOOTING

Problem	Possible Cause	Solution
1. No Display on PC Board	a. No power at electric outlet	a. Repair outlet or use working outlet
	b. Control valve Power Adapter not plugged into outlet or power cord end not connected to PC board connection	b. Plug Power Adapter into outlet or connect power cord end to PC Board connection
	c. Improper power supply	c. Verify proper voltage is being delivered to PC Board
	d. Defective Power Adapter	d. Replace Power Adapter
	e. Defective PC Board	e. Replace PC Board
2. PC Board does not display correct time of day	a. Power Adapter plugged into electric outlet controlled by light switch	a. Use uninterrupted outlet
	b. Tripped breaker switch and/or tripped GFI	b. Reset breaker switch and/ or GFI switch
	c. Power outage	c. Reset time of day. If PC Board has battery back up present the battery may be depleted. See Front Cover and Drive Assembly drawing for instructions.
	d. Defective PC Board	d. Replace PC Board
3. Display does not indicate that water is flowing. Refer to user instructions for how the display indicates water is flowing	a. Bypass valve in bypass position	a. Turn bypass handles to place bypass in service position
	b. Meter is not connected to meter connection on PC Board	b. Connect meter to three pin connection labeled METER on PC Board
	c. Restricted/ stalled meter turbine	c. Remove meter and check for rotation or foreign material
	d. Meter wire not installed securely into three pin connector	d. Verify meter cable wires are installed securely into three pin connector labeled METER
	e. Defective meter	e. Replace meter
	f. Defective PC Board	f. Replace PC Board
4. Control valve backwashes at wrong time of day	a. Power outage	a. Reset time of day. If PC Board has battery back up present the battery may be depleted. See Front Cover and Drive Assembly drawing for instructions.
	b. Time of day not set correctly	b. Reset to correct time of day
	c. Time of backwash set incorrectly	c. Reset backwash time
	d. Control valve set at immediate regeneration	d. Check programming setting and reset to DELAYED (for a delayed regen time)
	e. Control valve set at (delayed + immediate)	e. Check programming setting and reset to DELAYED (for a delayed regen time)
5. Time of day flashes on and off	a. Power outage	a. Reset time of day. If PC Board has battery back up present the battery may be depleted. See Front Cover and Drive Assembly drawing for instructions.
6. Control valve does not backwash automatically when the REGEN button is depressed	a. Broken drive gear or drive cap assembly	a. Replace drive gear or drive cap assembly
	b. Broken Piston Rod	b. Replace piston rod
	c. Defective PC Board	c. Replace PC Board
7. Control valve does not backwash automatically but does when the REGEN button is depressed and held.	a. Bypass valve in bypass position	a. Turn bypass handles to place bypass in service position
	b. Meter is not connected to meter connection on PC Board	b. Connect meter to three pin connection labeled METER on PC Board
	c. Restricted/ stalled meter turbine	c. Remove meter and check for rotation or foreign material
	d. Incorrect programming	d. Check for programming error
	e. Meter wire not installed securely into three pin connector	e. Verify meter cable wires are installed securely into three pin connector labeled METER
	f. Defective meter	f. Replace meter
	g. Defective PC Board	g. Replace PC Board

Problem	Possible Cause	Solution
8. Untreated water is being delivered	a. Bypass valve is open or faulty	a. Fully close bypass valve or replace
	b. Media is exhausted due to high water usage	b. Check program settings or diagnostics for abnormal water usage
	c. Meter not registering	c. Remove meter and check for rotation or foreign material
	d. Water quality fluctuation	d. Test water and adjust program values accordingly
	e. Damaged seal/stack assembly	e. Replace seal/stack assembly
	f. Control valve body type and piston type mix matched	f. Verify proper control valve body type and piston type match
	g. Fouled media bed	g. Replace media bed
9. For aeration and ozone generator models only: Control valve fails to draw in air or ozone.	a. Injector is plugged	a. Remove injector and clean or replace
	b. Faulty regenerant piston	b. Replace regenerant piston
	c. Ozone generator line connection leak	c. Inspect ozone line for air leak
	d. Air (Brine) elbow check valve cartridge or ozone in-line check valve defective or installed backwards	d. Remove check valve(s) and replace correctly
	e. Drain line restriction or debris cause excess back pressure	e. Inspect drain line and clean to correct restriction
	f. Drain line to long or too high	f. Shorten length and or height
	g. Low water pressure	g. Check incoming water pressure - water pressure must remain at minimum of 25 psi
10. Water running to drain	a. Power outage during backwash	a. Upon power being restored control will finish the remaining backwash time. Reset time of day
	b. Damaged seal/ stack assembly	b. Replace seal/ stack assembly
	c. Piston assembly failure	c. Replace piston assembly
	d. Drive cap assembly not tightened in properly	d. Re-tighten the drive cap assembly
11. Error – 101 = Control unable to sense motor movement	a. Motor not inserted full to engage pinion, motor wires broken or disconnected	a. Disconnect power, make sure motor is fully engaged, check for broken wires, make sure two pin connector on motor is connected to the two pin connection on the PC Board labeled MOTOR. Press NEXT and REGEN buttons for 3 seconds to resynchronize software with piston position or disconnect power supply from PC Board for 5 seconds and then reconnect.
	b. PC Board not properly snapped into drive bracket	b. Properly snap PC Board into drive bracket and then Press NEXT and REGEN buttons for 3 seconds to resynchronize software with piston position or disconnect power supply from PC Board for 5 seconds and then reconnect.
	c. Missing reduction gears	c. Replace missing gears

Problem	Possible Cause	Solution
<p>12. Error – 102 = Control valve motor ran too short and was unable to find the next cycle position and stalled</p>	<p>a. Foreign material is lodged in control valve</p>	<p>a. Open up control valve and pull out piston assembly and seal/ stack assembly for inspection. Press NEXT and REGEN buttons for 3 seconds to resynchronize software with piston position or disconnect power supply from PC Board for 5 seconds and then reconnect.</p>
	<p>b. Mechanical binding</p>	<p>b. Check piston and seal/ stack assembly, check reduction gears, check drive bracket and main drive gear interface. Press NEXT and REGEN buttons for 3 seconds to resynchronize software with piston position or disconnect power supply from PC Board for 5 seconds and then reconnect.</p>
	<p>c. Main drive gear too tight</p>	<p>c. Loosen main drive gear. Press NEXT and REGEN buttons for 3 seconds to resynchronize software with piston position or disconnect power supply from PC Board for 5 seconds and then reconnect.</p>
	<p>d. Improper voltage being delivered to PC Board</p>	<p>d. Verify that proper voltage is being supplied. Press NEXT and REGEN buttons for 3 seconds to resynchronize software with piston position or disconnect power supply from PC Board for 5 seconds and then reconnect.</p>
<p>13. Error – 103 = Control valve motor ran too long and was unable to find the next cycle position</p>	<p>a. Motor failure during a backwash</p>	<p>a. Check motor connections then Press NEXT and REGEN buttons for 3 seconds to resynchronize software with piston position or disconnect power supply from PC Board for 5 seconds and then reconnect.</p>
	<p>b. Foreign matter built up on piston and stack assemblies creating friction and drag enough to time out motor</p>	<p>b. Replace piston and stack assemblies. Press NEXT and REGEN buttons for 3 seconds to resynchronize software with piston position or disconnect power supply from PC Board for 5 seconds and then reconnect.</p>
	<p>c. Drive bracket not snapped in properly and out enough that reduction gears and drive gear do not interface</p>	<p>c. Snap drive bracket in properly then Press NEXT and REGEN buttons for 3 seconds to resynchronize software with piston position or disconnect power supply from PC Board for 5 seconds and then reconnect.</p>
<p>14. Error – 104 = Control valve motor ran too long and timed out trying to reach home position</p>	<p>a. Drive bracket not snapped in properly and out enough that reduction gears and drive gear do not interface</p>	<p>a. Snap drive bracket in properly then Press NEXT and REGEN buttons for 3 seconds to resynchronize software with piston position or disconnect power supply from PC Board for 5 seconds and then reconnect.</p>

Problem	Possible Cause	Solution
<p>15. Error -106 = MAV/ SEPS/ NHBP/ AUX MAV valve motor ran too long and unable to find the proper park position</p> <p>Motorized Alternating Valve = MAV</p> <p>Separate Source = SEPS</p> <p>No Hard Water Bypass = NHBP</p> <p>Auxiliary MAV = AUX MAV</p>	<p>a. Control valve programmed for ALT A or B, nHbP, SEPS, or AUX MAV with out having a MAV or NHBP valve attached to operate that function</p>	<p>a. Press NEXT and REGEN buttons for 3 seconds to resynchronize software with piston position or disconnect power supply from PC Board for 5 seconds and then reconnect. Then re-program valve to proper setting</p>
	<p>b. MAV/ NHBP motor wire not connected to PC Board</p>	<p>b. Connect MAV/ NHBP motor to PC Board two pin connection labeled MAV MTR. Press NEXT and REGEN buttons for 3 seconds to resynchronize software with piston position or disconnect power supply from PC Board for 5 seconds and then reconnect.</p>
	<p>c. MAV/ NHBP motor not fully engaged with reduction gears</p>	<p>c. Properly insert motor into casing, do not force into casing. Press NEXT and REGEN buttons for 3 seconds to resynchronize software with piston position or disconnect power supply from PC Board for 5 seconds and then reconnect</p>
	<p>d. Foreign matter built up on piston and stack assemblies creating friction and drag enough to time out motor</p>	<p>d. Replace piston and stack assemblies. Press NEXT and REGEN buttons for 3 seconds to resynchronize software with piston position or disconnect power supply from PC Board for 5 seconds and then reconnect.</p>
<p>16. Error – 107 = MAV/ SEPS/ NHBP/ AUX MAV valve motor ran too short (stalled) while looking for proper park position</p> <p>Motorized Alternating Valve = MAV</p> <p>Separate Source = SEPS</p> <p>No Hard Water Bypass = NHBP</p> <p>Auxiliary MAV = AUX MAV</p>	<p>a. Foreign material is lodged in MAV/ NHBP valve</p>	<p>a. Open up MAV/ NHBP valve and check piston and seal/ stack assembly for foreign material. Press NEXT and REGEN buttons for 3 seconds to resynchronize software with piston position or disconnect power supply from PC Board for 5 seconds and then reconnect.</p>
	<p>b. Mechanical binding</p>	<p>b. Check piston and seal/ stack assembly, check reduction gears, drive gear interface, and check MAV/ NHBP black drive pinion on motor for being jammed into motor body. Press NEXT and REGEN buttons for 3 seconds to resynchronize software with piston position or disconnect power supply from PC Board for 5 seconds and then reconnect.</p>



A DIVISION OF C-B TOOL CO.

1340 MANHEIM PIKE • LANCASTER PA 17601-3196 • TEL:717-397-3521 • FAX: 717-392-0266
www.lancasterwatergroup.com • E-mail: info@lancasterwatergroup.com