



LANCASTER

WATER TREATMENT

INSTALLATION, OPERATING AND SERVICE MANUAL

FULLY AUTOMATIC WATER SOFTENER

- 7-LC56-24B
- 7-L56-24B
- 7-L56-32B
- 7-L56-45B

IRON SOFT - FINE MESH RESIN

- 7-CFES-24B
- 7-FES-24B
- 7-FES-32B

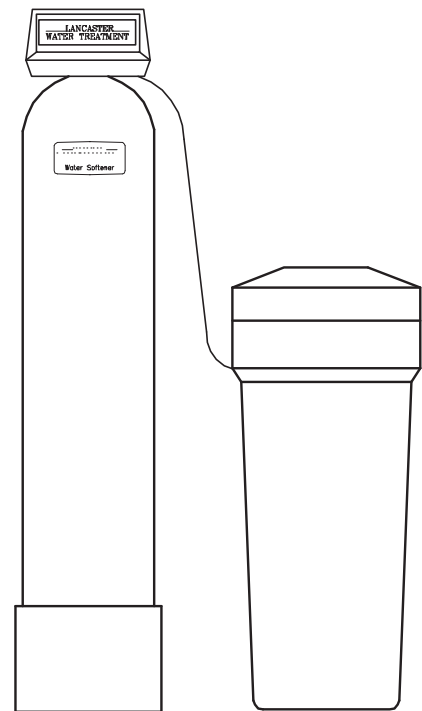

Congratulations on purchasing your new **Lancaster Water Softener**. This unit is designed to give you many years of trouble free service. When installed in accordance with the following instructions and if given reasonable care, clear-soft water will be the result. For servicing and future inspection purposes, please file this booklet with your important documents. In the event that you need assistance for servicing your water softener, please first contact the professional contractor who installed the system.

INSTALLATION

Place softener in desired location close to water supply inlet, after pressure tank, and near a source for waste water, (utility sink, floor drain or sewer line). Keep far enough away from walls and other obstructions to allow enough room for servicing the unit. All sillcocks and similar fixtures that will use untreated water must have their pipes connected to the hard water side of the softener. A bypass valve should be installed so that water will be available if it should be necessary to shut off the pressure in order to service the softener.

The cabinet tank or mineral tank must be reasonably level and solidly in place. Prior to beginning work to the system, make sure that water pressure is shut off at the incoming water supply and that several water spigots are open to prove sufficient venting for drainage of that system.

Arrows are molded into the control valve to show the direction of the flow.

OPTIONAL BYPASS VALVE: The bypass valve easily connects to the control valve body using screws and adapter clips. Install with red handle in the upward position. Press slip end of bypass valve onto in/out connections of valve. Take care not to crimp o-rings. Place into **BYPASS POSITION**. Do not use Vaseline or other unacceptable lubricants on o-rings. A silicone lubricant may be used on black o-rings.

DRAIN LINE: Drain line fitting accommodates 1/2" I.D. flexible poly tube.

It is simplest to run the drain line into a sump pump pit or washing machine drain if possible. If this is not practical, a fitting with a trap must be installed in a sewer line. Place the trap as close to the vent as possible to prevent siphoning of the trap when large amounts of waste water go through the sewer line. **DO NOT** pipe the drain line solidly into the waste line, as this is prohibited by most plumbing codes. The drain line should enter the trap from above so the water will not back up in the drain line if sewer should become plugged up and the trap overflow. The trap should have a short pipe extending from it to prevent splashing when water runs into the trap from drain line.

BRINE LINE CONNECTIONS: 3/8" poly tube is shipped inside of the brine tank along with a fittings package.

MAKE CONNECTION TO BRINE TANK: Push the polytube into the brine elbow until it is fully seated into the fitting.

MAKE CONNECTION TO CONTROL VALVE: Slide brass nut onto 3/8" poly tube. Slide ferrule onto poly tube **as shown in diagram**. Install tube insert. Press fully into brine valve fitting. Tighten brass nut.

BRINE TANK OVERFLOW PRECAUTION: Attach a 1/2" poly tube (not provided) to the barbed fitting on the outside of the tank. This poly tube should be piped to drain to allow brine to discharge to drain in the event of an overflow condition.

SANITIZING: (This is to be done after placing unit into service - see next page.) Use 2 oz. of 5¼% household chlorine bleach for each cubic foot of resin. Pour bleach directly into the brine well of the softener. Manually index the softener to the REGEN position. Allow system to complete the regeneration automatically. Check for other local and state codes which may also specify sanitation methods.

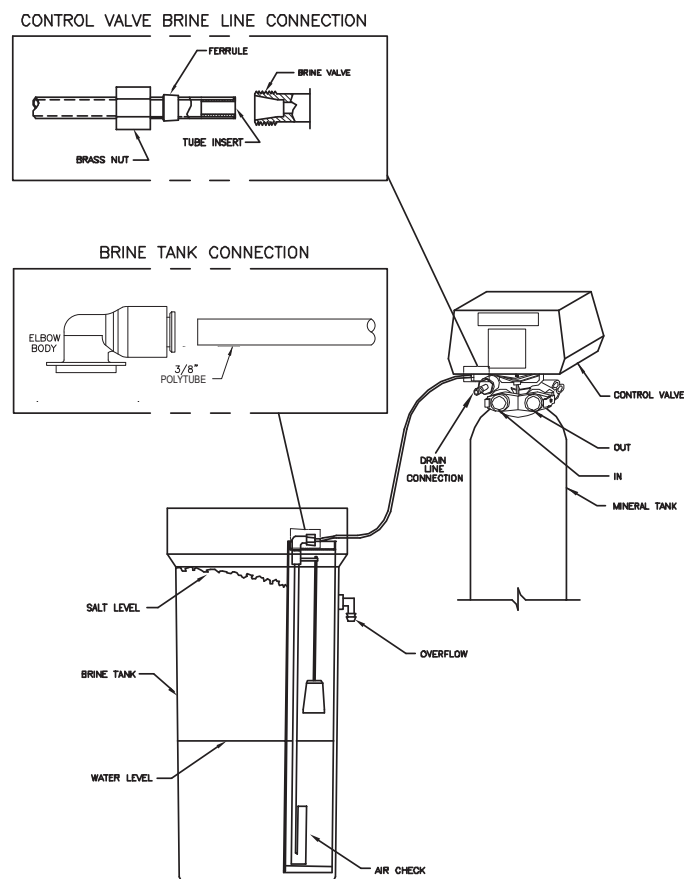

PLACING UNIT INTO SERVICE:

1. Manually index the softener control into the BACKWASH position. Slowly open bypass valve and allow water to flow into the resin tank. When the water flows steadily to drain without the presence of air, index control to IN SERVICE position.

NOTE: the various regeneration positions may be dialed manually by turning the knob on the front of the control clockwise until the indicator shows that the softener is in the desired position. VARIOUS REGENERATION POSITIONS ARE:

- | | | | |
|-------------|--------------|------------------|-----------------|
| 1. IN SERV. | 3. RINSE | 5. BRINE + RINSE | 7. SETTLE RINSE |
| 2. REGEN. | 4. BACK WASH | 6. RAPID RINSE | 8. BRINE REFILL |

2. Set regeneration intervals. To set days that regeneration is to occur, slide tabs on skipper wheel outward to expose trip fingers. Each tab represents one day. The finger at the red pointer represents tonight. Moving clockwise from red pointer, extend or retract fingers to obtain desired regeneration schedule.
3. Add 1-1/2 gallons of water to the brine tank.
4. Plug in the electrical cord and look in the sight hole in the back of the motor to see that it is running.
5. Set the correct time of day.
6. Manually advance the control to the beginning of the brine refill position and allow the control to return to the service position automatically.
7. Fill the brine tank with salt. Maintain salt level above water level. We recommend Solar Salt.
8. Make sure bypass valve is in the service position.

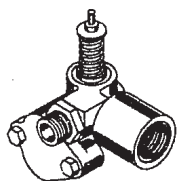
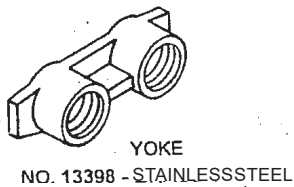
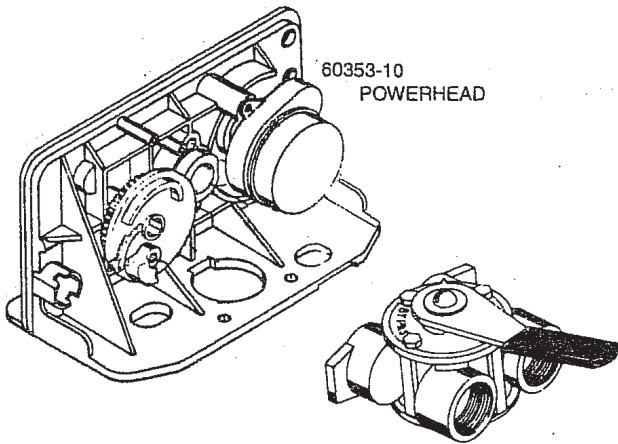
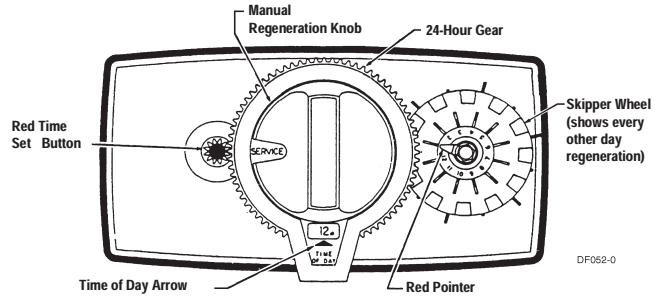

- INJECTOR/DRAIN MODULE ASSY.
 NO.60084-0121, #1 INJ., .25 BLFC, 1.5 DLFC
 NO.60084-0122, #1 INJ., .50 BLFC, 1.5 DLFC
 NO.60084-0141, #1 INJ., .25 BLFC, 2.4 DLFC
 NO.60084-0142, #1 INJ., .50 BLFC, 2.4 DLFC

GRAINS OF HARDNESS TO BE REMOVED DAILY

Grains Hardness	Number of Persons in Family					
	2	3	4	5	6	7
6	600	900	1200	1500	1800	2100
8	800	1200	1600	2000	2400	2800
10	1000	1500	2000	2500	3000	3500
12	1200	1800	2400	3000	3600	4200
14	1400	2100	2800	3500	4200	4900
16	1600	2400	3200	4000	4800	5600
18	1800	2700	3600	4500	5400	6300
20	2000	3000	4000	5000	6000	7000
22	2200	3300	4400	5500	6600	7700
25	2500	3750	5000	6250	7500	8750
30	3000	4500	6000	7750	9000	14000
35	3500	5250	7000	9000	10400	15750

INSTRUCTIONS FOR SELECTING REGENERATION INTERVAL

To choose the proper regeneration interval, first check the specification table to determine the total grains hardness per day to be removed. The industry figures 50 gallons of water per person per day will be used. An automatic washer is figured as a person. Frequent regeneration is beneficial, particularly when larger amounts of iron are involved.

Example: Family of 4 at 50 gallons each with 13 grains hardness.

200 x 13 = 2600 grains per day to be removed.

2600 x 6 = 15600 grains to be removed by 6 day cycle.

2600 x 12 = 31200 grains to be removed by 12 day cycle.

To obtain maximum efficiency per pound of salt, the softener should be set to regenerate at an interval that will utilize the full capacity of the mineral. If 5 parts per million or more of iron are present, it is recommended that the softener be regenerated at least once every 4 days.

FULLY AUTOMATIC WATER SOFTENERS

Model No.	L56-24B	L56-32B	L56-45B	LC56-24B
Salt - Lbs.	12	15	22	12
Capacity	24,000	32,000	45,000	24,000

"IRONSOFT" FINE MESH RESIN UNITS

Model No.	FES-24B	FES-32B	FES-45B	CFES-24B
Salt - Lbs.	12	15	22	12
Capacity	24,000	32,000	45,000	24,000

**NO. 60353-10 POWER HEAD ASSEMBLY
(LESS COVER)**

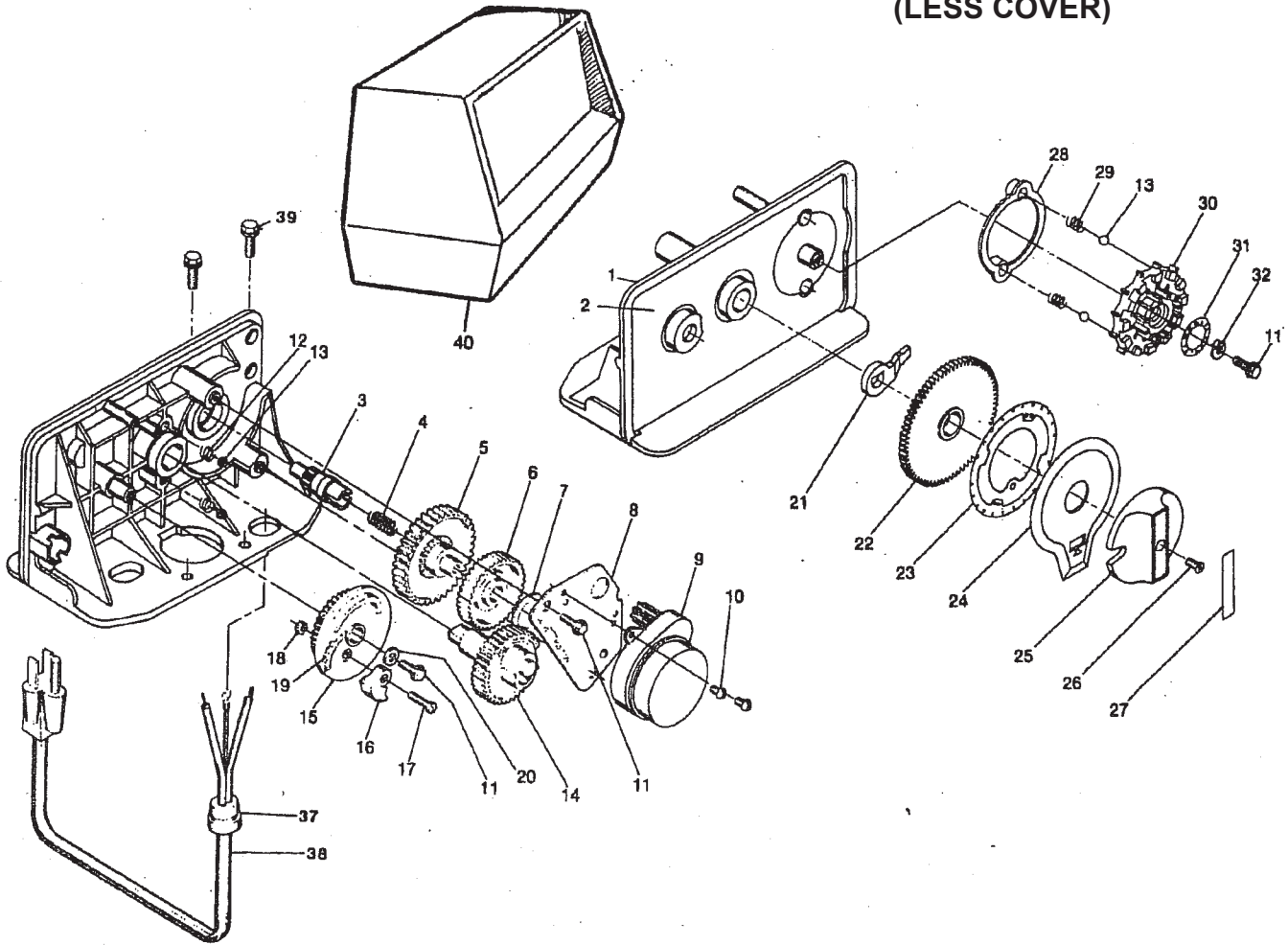

Item No.	Qty.	Part No.	Description	Item No.	Qty.	Part No.	Description
1	1	15494	Drive Panel	19	1	13489	Label - "Lbs of Salt - 6-36"
2	1	14331	Front Label	20	1	12037	Washer
3	1	13018	Idler Pinion	21	1	13011	Cycle Actuator Arm
4	1	13312	Idler Spring	22	1	13009	24 Hour Gear Assy.
5	1	13017	Idler Gear	23	1	13959	24 Hour Label
6	1	13164	Drive Gear	24	1	14176	Valve Position Dial
7	1	13299	Curved Washer	25	1	14177	Knob
8	1	13175	Motor Mounting Plate	26	1	15151	Screw - Knob
9	1	18743	Motor - 110 V. 1/30 RPM	27	1	14207	Knob Label
10	3	11384	Screw	28	1	13864	Skipper Wheel Ring
11	3	13296	Screw	29	2	13311	Spring
12	2	14457	Spring	30	1	14381	Skipper Wheel Assy.
13	2	13300	Ball	31	1	13429	Skipper Wheel Label
14	1	13170	Main Gear & Shaft	32	1	13014	Regeneration Pointer
15	1	13168	Brine Cam Assy.	37	1	13547	Strain Relief
16	1	13169	Time Fill Cam	38	1	11842	Electrical Cord
17	1	11980	Screw - Time Fill Cam	39	2	12473	Screw-Drive Mounting
18	1	11081	Nut - Time Fill Cam	40	1	60226	Black Cover

CONTROL VALVE ASSEMBLY

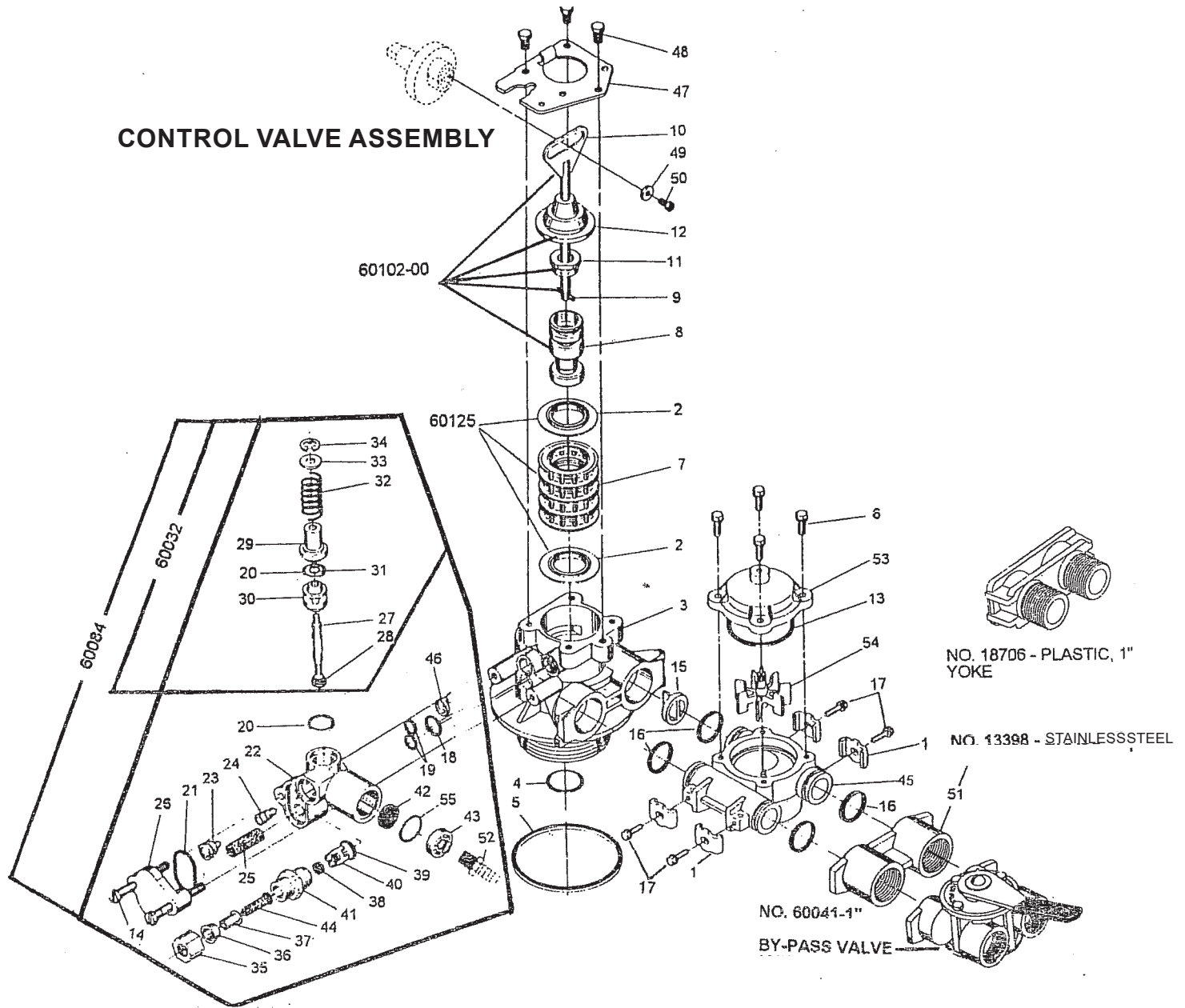

Item No.	Qty.	Part No.	Description	Item No.	Qty.	Part No.	Description	Item No.	Qty.	Part No.	Description
1	2	13255	Adapter Clips	20	2	13302	O-Ring	39	1	12977	O-Ring
2	5	13242	Seals	21	1	13303	O-Ring	40	1	13245	Retainer
3	1	61400-12	Valve Body Assy. - 1"	22	1	13163	Injector Body	41	1	13244	B.L.F.C. Fitting
4	1	13304	O-Ring	23	1	10913	Injector Nozzle	42	1	12085	1.2 GPM Button - CFES
5	1	12281	O-Ring	24	1	10914	Injector Throat		1	12086	1.5 GPM Button - L56-16-24
7	4	14241	Spacer	25	1	10227	Injector Screen		1	12089	2.4 GPM Button - L56-32, 45
8	1	13247	Piston - L56	26	1	13166	Injector Cover	43	1	13173	Retainer
	1	13852	Piston - FES	27	1	13172	Brine Valve Stem	46	1	13497	Air Dispenser
9	1	10696	Piston Pin	28	1	12626	Brine Valve Seat	47	1	13546	End Plug Retainer
10	1	13001	Piston Rod Assy.	29	1	13165	Brine Valve Cap	48	3	12112	Screws
11	1	12953	Piston Retainer	30	1	13167	Brine Valve Spacer	49	1	13363	Washer
12	1	13446	End Plug Assy. - L56	31	1	12550	Quad Ring	50	1	13296	Screw
	1	13446-10	End Plug Assy. - FES	32	1	11973	Spring	52	1	13308	Drain Line Fitting
14	2	13315	Screw	33	1	16098	Washer	55	1	15348	O-Ring
15	2	19228	Adapter Coupling	34	1	11981	Retaining Ring			60032	Brine Valve Assy.
16	4	13305	O-Ring	35	1	10329	Fitting Nut			60084	Injector/Drain Assy.
17	4	13314	Screw	36	1	10330	Ferrule			60102-00	Piston Assy. - L56
18	1	12638	O-Ring	37	1	10332	Tube Insert			60102-10	Piston Assy. - FES
19	2	13301	O-Ring	38	1	12095	Button - .50 GPM			60125	Seal Kit

NO. 60041 BYPASS VALVE ASSEMBLY 1"

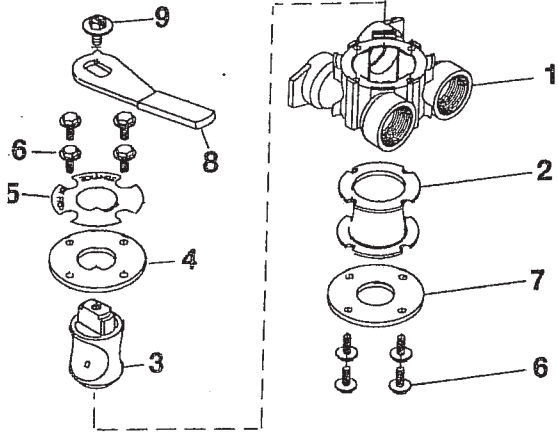

Item No.	Qty.	Part No.	Description
1	1	13399	Valve Body 1" NPT
2	1	11726	Bypass Seal
3	1	11972	Bypass Plug
4	1	11978	Side Cover
5	1	13604	Valve Label
6	8	15727	10-24 x 1/2" machine Screw
7	1	11986	Side Cover
8	1	11979	Valve Lever
9	1	11989	1/4"-14 x 1/2" Machine Screw

60049 PLASTIC BYPASS

Item No.	Qty.	Part No.	Description
1	1	19723	Bypass Valve Body, Plastic
2	1	11183	O-Ring
3	1	19724	Cap, Bypass
4	2	17512	#6-24x3 Screw
5a	1	17820	Plug, Bypass, Inlet (White)
5b	1	17820-01	Plug, Bypass, Outlet (White)
6	4	18661	O-Ring
7	2	18662	Retaining Ring
8	2	18660	O-Ring
9	2	13305	O-Ring
10	2	13255	Mounting Clip
11	2	13314	#8-18 x 5/8 Screw
12a	1	18706	Yoke, Plastic, 1" NPT

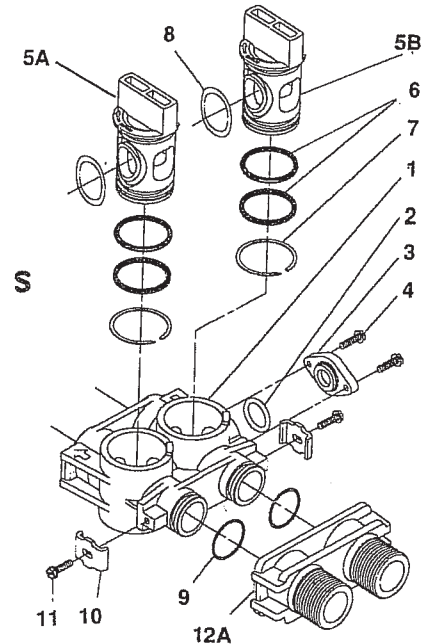

4740 BRINE VALVE ASSEMBLY

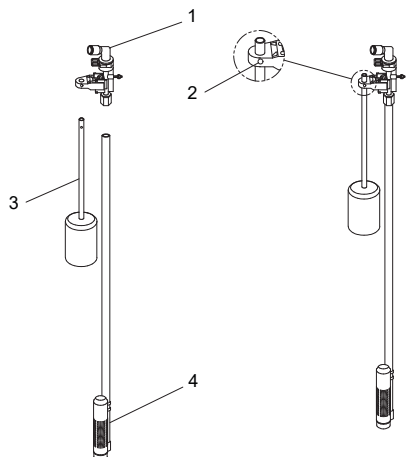

Item No.	Qty.	Part No.	Description
1	1	H4600	3/8" Safety Brine Valve
2	1	10151	Pin
3	1	H4640-9.5	Float Assembly
4	1	H4500-48	Air Check Assembly (uncut length)

J7952 15 x 17 x 36
Brine Tank Assy.

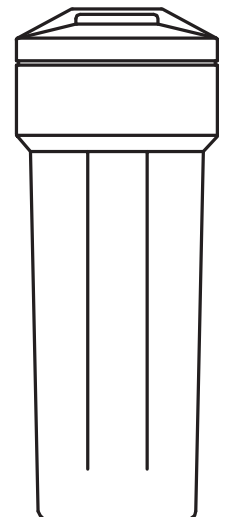

SERVICE INSTRUCTIONS

TO REPLACE BRINE VALVE, INJECTORS, AND SCREEN: Unplug electrical cord from outlet. Turn off water supply to softener. Relieve water pressure in the softener by putting the control in the backwash position momentarily. Return the control to the service position. Disconnect brine tube and drain line connections at the injector body. Remove the two injector body mounting screws. The injector and brine module can now be removed from the control valve. Remove and discard valve body O-Rings.

TO REPLACE BRINE VALVE: Pull brine valve from injector body, also remove & discard O-Ring at bottom of brine valve hole. Apply silicone lubricant to new O-Ring and reinstall at bottom of brine valve hole. Apply silicone lubricant to O-Ring on new valve assembly and press into brine valve hole, shoulder on bushing should be flush with injector body.

TO REPLACE INJECTORS AND SCREEN: Remove injector cap and screen, discard O-Ring. Unscrew injector nozzle and throat from injector body. Screw in new injector throat and nozzle, be sure they are seated tightly. Install a new screen. Apply silicone lubricant to new O-Ring and install around oval extension on injector cap.

Apply silicone lubricant to the three new O-Rings and install over three bosses on injector body. Insert screws with washers through injector cap and injector. Place this assembly through hole in timer housing and into mating holes in the valve body. Tighten screws. Reconnect brine tube and drain line. Return bypass or inlet valving to normal service position. Water pressure should now be applied to the softener. Check for leaks at all seal areas. Check drain seal with the control in the backwash position. Plug electrical cord into outlet. Set time of day and cycle the control valve manually to assure proper function. Make sure the control valve is returned to the service position. Make sure there is enough brine in the brine tank. Rotate program wheel counter-clockwise until it stops at regeneration position. Start regeneration cycle manually if water is hard.

TO REPLACE TIMER (POWER HEAD ASSEMBLY): Unplug electrical cord from outlet. Turn off water supply to softener. Relieve water pressure in the softener by putting the control in the backwash position momentarily. Return the control to the service position. Remove screw and washer at drive yoke. Remove timer mounting screws. The entire timer assembly will now lift off easily. Put new timer on top of valve. Be sure drive pin on main gear engages slot in drive yoke (rotate control knob if necessary). Replace timer mounting screws. Replace screw and washer at drive yoke. Return bypass or inlet valving to normal service position. Water pressure should now be applied to the softener. Plug electrical cord into outlet. Set time of day. Cycle the control valve manually to assure proper function. Make sure the control valve is returned to the service position. Make sure there is enough brine in the brine tank. Rotate program wheel counter-clockwise until it stops at regeneration position. Start regeneration cycle manually if water is hard.

TO REPLACE PISTON ASSEMBLY: Unplug electrical cord from outlet. Turn off water supply to softener. Relieve water pressure in the softener by putting the control in the backwash position momentarily. Return the control to the service position. Remove screw and washer at drive yoke. Remove timer mounting screws. The entire timer assembly will now lift off easily. Remove end plug retainer plate. Pull upward on end of piston yoke until assembly is out of valve. Inspect the inside of the valve to make sure that all spacers and seals are in place, and that there is no foreign matter that would interfere with the valve operation. Take new piston assembly as furnished and push piston into valve by means of the end plug. Twist yoke carefully in a clockwise direction to properly align it with drive gear. Replace end plug retainer plate. Place timer on top of valve. Be sure drive pin on main gear engages slot in drive yoke (rotate control knob if necessary). Replace timer mounting screws. Replace screw and washer at drive yoke. Return bypass or inlet valving to normal service position. Water pressure should now be applied to the softener. Plug electrical cord into outlet. Set time of day. Cycle the control valve manually to assure proper function. Make sure the control valve is returned to the service position. Make sure there is enough brine in the brine tank. Rotate program wheel counter-clockwise until it stops at regeneration position. Start regeneration cycle manually if water is hard.

TO REPLACE SEALS AND SPACERS: Unplug electrical cord from outlet. Turn off water supply to conditioner. Relieve water pressure in the softener by putting the control in the backwash position momentarily. Return the control to the service position. Remove screw and washer at drive yoke. Remove timer mounting screws. The entire timer assembly will now lift off easily. Remove end plug retainer plate. Pull upward on end of piston rod yoke until assembly is out of valve. Remove and replace seals and spacers with fingers.

TROUBLESHOOTING PROCEDURES

PROBLEM	POSSIBLE CAUSE	SOLUTION
1. Softener fails to regenerate.	<ul style="list-style-type: none"> a. Electrical service to unit has been interrupted. b. Timer is defective. c. Power failure. 	<ul style="list-style-type: none"> a. Assure permanent electrical service. b. Replace timer. c. Reset time of day.
2. Softener delivers hard water.	<ul style="list-style-type: none"> a. By-pass valve is open. b. No salt in brine tank. c. Injectors or screen plugged. d. Insufficient water flowing into brine tank. e. Hot water tank hardness. f. Leak at distributor tube. g. Internal valve leak. h. Reserve Capacity has been exceeded. 	<ul style="list-style-type: none"> a. Close by-pass valve. b. Maintain salt level above water level. c. Clean or replace injectors and screen. d. Check fill time and clean brine line plug if clogged. e. Empty hot water tank. f. Make sure distributor tube is not cracked. Check O-Ring and tube pilot. g. Replace seals and spacer and/or piston. h. Check Salt dosage requirements and reset program wheel to provide additional reserve.
3. Unit uses too much salt.	<ul style="list-style-type: none"> a. Improper salt setting. b. Excessive water in brine tank. 	<ul style="list-style-type: none"> a. Check salt usage and salt setting. b. See problem no. 7.
4. Loss of water pressure.	<ul style="list-style-type: none"> a. Iron buildup in line to water conditioner. b. Iron buildup in water conditioner. c. Inlet of control plugged by foreign material. 	<ul style="list-style-type: none"> a. Clean line to water conditioner. b. Clean control, increase frequency of regeneration and use a resin cleaner. c. Remove piston and clean control.
5. Loss of resin out of drain line.	<ul style="list-style-type: none"> a. Air in water system. 	<ul style="list-style-type: none"> a. Assure that well system has proper air eliminator control. Check for dry well condition.
6. Iron in conditioned water.	<ul style="list-style-type: none"> a. Fouled resin bed. 	<ul style="list-style-type: none"> a. Check backwash, brine draw and brine tank fill. Increase frequency of regeneration and use a resin cleaner.
7. Excessive water in brine tank.	<ul style="list-style-type: none"> a. Plugged drain line flow control. b. Plugged injector system. c. Timer not cycling. d. Foreign material in brine valve. e. Foreign material in brine line flow control. 	<ul style="list-style-type: none"> a. Clean flow control. b. Clean injector and replace screen. c. Replace timer. d. Clean or replace brine valve. e. Clean brine line flow control.
8. Softener fails to draw brine.	<ul style="list-style-type: none"> a. Drain line flow control is plugged. b. Injector is plugged. c. Injector screen plugged. d. Line pressure is too low. e. Internal control leak. 	<ul style="list-style-type: none"> a. Clean drain line flow control. b. Clean or replace injectors. c. Replace screen. d. Increase line pressure to at least 20 psi. e. Change seals and spacers and/or piston assy.
9. Control cycles continuously.	<ul style="list-style-type: none"> a. Faulty timer mechanism 	<ul style="list-style-type: none"> a. Replace timer.
10. Drain flows continuously.	<ul style="list-style-type: none"> a. Foreign material in control. b. Internal control leak. c. Control valve jammed in brine or backwash position. d. Timer motor stopped or jammed. 	<ul style="list-style-type: none"> a. Advance control through various regeneration positions. Remove foreign material in control. b. Replace seals and/or piston assy. c. Replace piston, seals and spacers. d. Replace timer.



A DIVISION OF C-B TOOL CO.

1340 MANHEIM PIKE • LANCASTER PA 17601-3196 • TEL:717-397-3521 • FAX: 717-392-0266

www.lancasterwatertreatment.com • E-mail: info@lancasterpump.com