



# LANCASTER

## WATER TREATMENT

DIAMOND LINE FESLX - CABINET IRONSOFT

### X-FACTOR SERIES CABINET IRONSOFT

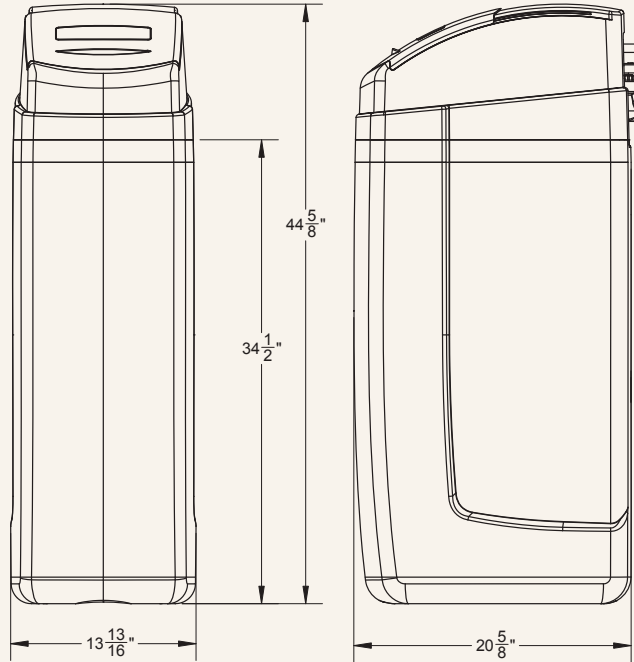

FESLX PROGRAM CYCLES*	CABINET IRONSOFT
<b>Model Number</b>	<b>7-FESLXC-24B</b>
<b>1st: Fill - LBS NaCl (Gallons)</b>	10 (3.33)
<b>2nd: Softening - Minutes (Gallons)</b>	60 (0)
<b>3rd: Backwash - Minutes (Gallons)</b>	10 (10)
<b>4th: Regenerant Draw DN &amp; Slow Rinse - Minutes (Gallons)</b>	50 (18.5)
<b>5th: Air Release - Seconds (Gallons)</b>	90 (1.5)
<b>6th: Backwash - Minutes (Gallons)</b>	10 (10)
<b>7th: Rinse - Minutes (Gallons)</b>	20 (20)
<b>8th: End</b>	-
<b>Total Gallons to Drain**</b>	63.3
<b>Total Minutes</b>	158.2

\*Downflow Regenerant, Prefill Factory Program Settings

\*\*Based on 50 PSI Inlet Pressure



## X-FACTOR SERIES FESLX CABINET IRONSOFT

FESLX SPECIFICATIONS	CABINET IRONSOFT
Model Number	7-FESLXC-24B
Inlet/Outlet Fitting Options (Inches) <sup>1</sup>	0.75 - 1.0 <sup>1</sup> - 1.25 - 1.5
Bypass Included	Yes
Drain Fit. Elb. NPT or OD Poly Tube Size (Inches)	3/4 NPT or 5/8 Tube
Water Pressure Range (PSI)	20 - 100
Water Operating Temperature Range (°F)	35 - 100
Influent Maximum Water Hardness (GPG)	100
Influent Maximum Ferrous Iron (PPM) <sup>2</sup>	10
Plug-In Power Adapter Input (VAC - Hz - A)	120V AC - 60Hz - 0.35A
Plug-In Power Adapter Output (VDC - A)	15V DC - 0.5A
Plug-In Power Adapter Cord Length	15 FT
PC Board Relay Terminal Block DC Output (V)	12V DC
3 Volt Lithium Coin Cell Battery (Type)	2032
Service Flow Rate at 15 PSI Pressure Drop (GPM) <sup>3</sup>	16
Overall Height (Inches)	44.63
Mineral Tank Size: Diameter x Height (Inches)	10 x 35
Bottom Distributor Type	Plate
Top Basket Distributor	No
Top Deflector	Yes
Amount of Resin (Cubic Feet)	0.66
#20 Flint, Medium & Fine Garnets Underbed Layer	Yes
Cabinet Size (Inches) <sup>4</sup>	13.81 x 20.63 x 44.63
Cabinet Capacity (LBS NaCl)	258
Drain Line Flow Control (GPM)	1.0
Brine Line (Re-Fill) Flow Control (GPM)	0.5
Injector (Color)	IE - White
Grains Capacity (Grains @ LBS NaCl) <sup>5</sup>	21,000 @ 10
Water to Drain at 50 PSI Inlet Pressure (Gallons)	63.3

<sup>1</sup>1.0 MNPT Elbow Standard - Options Available

<sup>2</sup>Ferrous iron ("clear-water iron"): Water comes out of the faucet clear, but turns red or brown after standing. Frequent regeneration required - Day Override factory set for 4 days between regenerations. Influent water to be treated should contain at least 1 gpg (2 gpg recommended) of hardness for each ppm or mg/L of ferrous iron, with a minimum of 3 gpg of hardness.

Example 1: For 1 ppm ferrous iron, water hardness should not be less than 3 gpg.

Example 2: For 4 ppm ferrous iron, water hardness should not be less than 4 gpg (8 gpg recommended).

This allows hardness dispersion with the iron on the exhausted resin, helping facilitate the removal of iron from the resin bed during regeneration. The Fine Mesh Resin bead size provides improved kinetics where extra surface area and a short diffusion path are needed for iron removal. Ferrous iron readily converts to ferric iron in the presence of oxygen, chlorine, or other oxidants. Ferric iron is insoluble and should be removed by filtration. Even if the influent has very low oxygen (which is very likely for the iron to remain in the ferrous state), the brine tank is never sealed therefore the brine used to regenerate contains oxygen. Ferrous iron precipitates right at the surface of the resin beads, potentially plugging up the resin bead pores, coating the beads and plugging up the flow spaces between the beads. Resin cleaner added to the brine solution is recommended for cleaning the softener resin bed.

<sup>3</sup>Flow rates in the table may exceed resin manufacturer's recommended maximum flow rates. Selecting a system flow rate by pressure drop alone does not guarantee that the system will provide softened water.

<sup>4</sup>See Diagram

<sup>5</sup>Factory Program Setting