



LANCASTER

WATER TREATMENT

DIAMOND LINE LX - CABINET SOFTENERS

X-FACTOR SERIES LX CABINET SOFTENERS

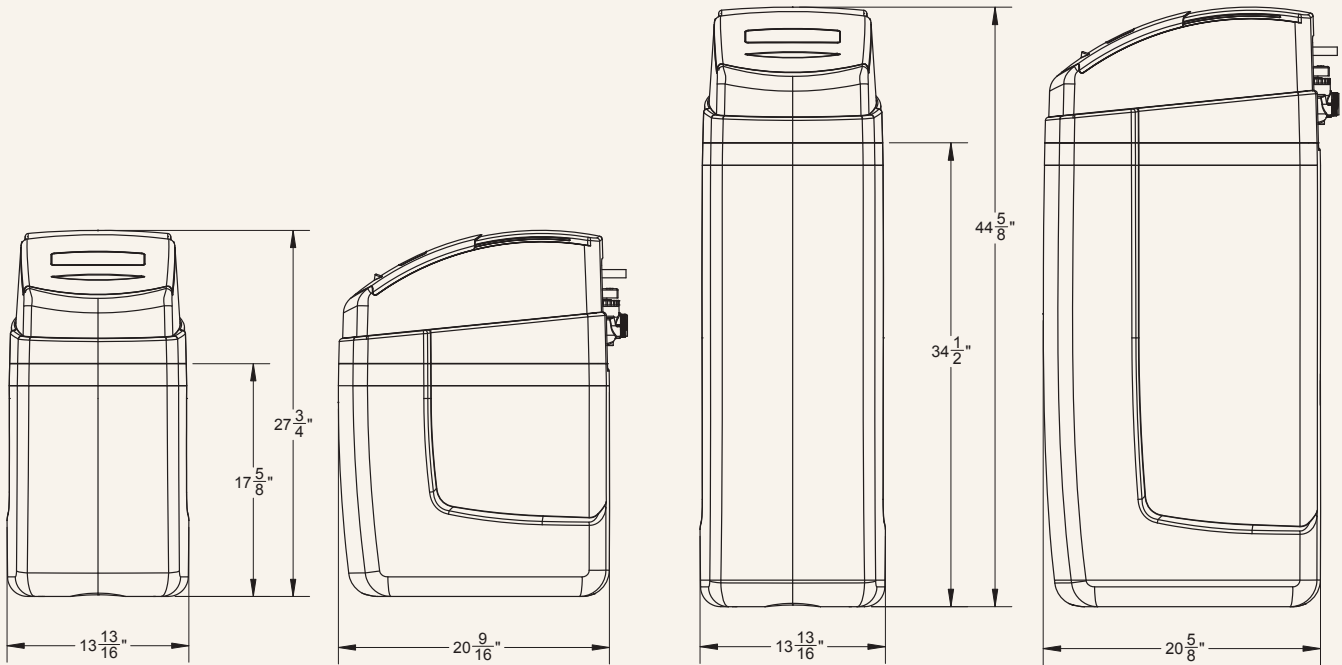

LX PROGRAM CYCLES*	CABINET SOFTENER		
Model Number	7-LXC-50B (Packed Bed)	7-LXC-75B	7-LXC-100B (Packed Bed)
1st: Fill - LBS NaCl (Gallons)	4.0 (1.33)	6.0 (2.0)	8.0 (2.67)
2nd: Softening - Minutes (Gallons)	60 (0)	60 (0)	60 (0)
3rd: Backwash - Minutes (Gallons)	N/A	10 (17)	N/A
4th: Regenerant Draw DN & Slow Rinse - Minutes (Gallons)	50 (15.77)	50 (18.5)	50 (18.53)
5th: Backwash - Minutes (Gallons)	N/A	10 (17)	N/A
6th: Rinse - Minutes (Gallons)	5 (3.5)	5 (8.5)	5 (5)
7th: End	-	-	-
Total Gallons to Drain**	20.6	63.0	26.2
Total Minutes	117.7	139.0	120.3

*Downflow Regenerant, Prefill Factory Program Settings

**Based on 50 PSI Inlet Pressure

X-FACTOR SERIES LX CABINET SOFTENERS

LX SPECIFICATIONS		CABINET SOFTENER		
Model Number		7-LXC-50B (Packed Bed)	7-LXC-75B	7-LXC-100B (Packed Bed)
Inlet/Outlet Fitting Options (Inches) ¹		0.75 - 1.0 ¹ - 1.25 - 1.5	0.75 - 1.0 ¹ - 1.25 - 1.5	0.75 - 1.0 ¹ - 1.25 - 1.5
Bypass Included		Yes	Yes	Yes
Drain Fit. Elb. NPT or OD Poly Tube Size (Inches)		3/4 NPT or 5/8 Tube	3/4 NPT or 5/8 Tube	3/4 NPT or 5/8 Tube
Water Pressure Range (PSI)		20 - 100	20 - 100	20 - 100
Water Operating Temperature Range (°F)		35 - 100	35 - 100	35 - 100
Influent Maximum Water Hardness (GPG)		100	100	100
Influent Maximum Ferrous Iron (PPM) ²		0	0.5	0
Plug-In Power Adapter Input (VAC - Hz - A)		120V AC - 60Hz - 0.35A	120V AC - 60Hz - 0.35A	120V AC - 60Hz - 0.35A
Plug-In Power Adapter Output (VDC - A)		15V DC - 0.5A	15V DC - 0.5A	15V DC - 0.5A
Plug-In Power Adapter Cord Length		15 FT	15 FT	15 FT
PC Board Relay Terminal Block DC Output (V)		12V DC	12V DC	12V DC
3 Volt Lithium Coin Cell Battery (Type)		2032	2032	2032
Service Flow Rate at 15 PSI Pressure Drop (GPM) ³		14	18	17
Overall Height (Inches)		27.75	44.63	44.63
Mineral Tank Size: Diameter x Height (Inches)		9 x 18	10 x 35	10 x 35
Bottom Distributor Type		Plate	Plate	Plate
Top Basket Distributor		Yes	Yes	Yes
Amount of Resin (Cubic Feet)		0.5	0.75	1.0
Cabinet Size (Inches) ⁴		13.81 x 20.56 x 27.75	13.81 x 20.63 x 44.63	13.81 x 20.63 x 44.63
Cabinet Capacity (LBS NaCl)		133	258	258
Drain Line Flow Control (GPM)		0.7	1.7	1.0
Brine Line (Re-Fill) Flow Control (GPM)		0.5	0.5	0.5
Injector (Color)		ID - Red	IE - White	IE - White
Grains Capacity (Grains @ LBS NaCl)	High	16,000 @ 7.5	24,000 @ 11.3	32,000 @ 15.0
	Medium ⁵	12,000 @ 4.0	18,000 @ 6.0	24,000 @ 8.0
	Low	8,500 @ 2.3	12,750 @ 3.4	17,000 @ 4.5
Water to Drain at 50 PSI Inlet Pressure (Gallons)	High	21.8	64.8	28.5
	Medium ⁵	20.6	63.0	26.2
	Low	20.0	62.1	25.0

¹1.0 MNPT Elbow Standard - Options Available

²Ferrous iron ("clear-water iron"): Water comes out of the faucet clear, but turns red or brown after standing. Recommend HIGH grains capacity program settings - Consult Factory

³Flow rates in the table may exceed resin manufacturer's recommended maximum flow rates. Selecting a system flow rate by pressure drop alone does not guarantee that the system will provide softened water.

⁴See Diagram

⁵Factory Program Setting